

**Chief Architect®
Home Designer Essentials® 2014**

Reference Manual

**Chief Architect, Inc.
6500 N. Mineral Dr.
Coeur d'Alene, Idaho 83815
www.HomeDesignerSoftware.com**

© 1990–2012 by Chief Architect, Inc. All rights reserved.

No part of this book or the accompanying software may be reproduced or transmitted in any form or by any means, electronic or mechanical, including photocopying, recording, or by any information storage and retrieval system, without permission in writing from Chief Architect, Inc.

Chief Architect® and Home Designer® are registered trademarks of Chief Architect, Inc.

This software uses the FreeImage open source image library. See <http://freeimage.sourceforge.net> for details.

FreeImage is used under the FIPL license, version 1.0.

This software uses the Ruby open source library. See <http://www.ruby-lang.org/> for details.

All other trademarks and copyrights are the property of Chief Architect, Inc. or their respective owners.

Created in the United States of America.

Contents

Chapter 1: Program Overview

Startup Options.....	17
The Home Designer Essentials Environment	18
Toolbars.....	20
Menus.....	21
Dialogs	22
The Status Bar	23
Message Boxes	23
Preferences and Default Settings.....	24
Drawing a Plan	25
Viewing Your Plan.....	26
Getting Help.....	27
About Home Designer Essentials	28
Upgrade to Chief Architect	28

Chapter 2: File Management

Compatibility with Other Programs.....	31
Organizing Your Files.....	31
Home Designer Essentials Data	32
Creating a New Plan	32
Saving, Exporting, and Backing Up Files	33
Auto Archive.....	36
Undo Files.....	37

Opening and Importing Files	37
Searching for Plans	38
Backup Entire Plan	42
Closing Views and Files.....	43
Exiting Home Designer Essentials.....	44

Chapter 3: Preferences & Default Settings

Default Settings vs Preferences.....	47
Dynamic Defaults.....	48
General Plan Defaults Dialog.....	48
Preferences Dialog	49

Chapter 4: Toolbars & Hotkeys

Toolbar Arrangement	57
Hotkeys.....	57

Chapter 5: Layers

Displaying Objects	59
Layer Sets.....	59
Display Options Dialog	60

Chapter 6: Creating Objects

Architectural vs CAD Objects.....	63
Snap Behaviors.....	63
Object Snaps.....	63
Angle Snaps	64
Grid Snaps.....	64
Creating Objects	64

Copying and Pasting Objects	66
-----------------------------------	----

Chapter 7: Editing Objects

Selecting Objects.....	71
Editing Line Based Objects	73
Editing Arc Based Objects.....	75
Editing Open Polyline Based Objects.....	77
Editing Closed-Polyline Based Objects.....	80
Editing Box-Based Objects.....	82
Editing Spline Based Objects	84
Displaying Objects.....	86
Moving Objects	88
Aligning Objects	89
Resizing Objects	90
Reshaping Objects	91
Rotating Objects	92
Deleting Objects.....	93
Undo and Redo	94

Chapter 8: Walls, Railings & Fencing

Wall Defaults	97
The Wall Tools.....	97
The Deck Tools	98
The Fencing Tools	99
Exterior and Interior Walls	99
Foundation Walls.....	100
Railings.....	100
Invisible Walls	101
Hatch Wall.....	102
Break Wall.....	102

Drawing Walls	103
Connecting Walls.....	104
Displaying Walls	105
Measuring Walls	106
Editing Walls	107
Editing Straight/Curved Wall Combinations	110
Aligning Walls	110
Roof Directives in Walls.....	111
Attic Walls	112
Wall Type Definitions	113
Wall Specification Dialog.....	114
Railing and Fencing Specification Dialogs	116
Wall Hatch Specification Dialog	119

Chapter 9: Rooms

Floor and Room Defaults	121
Room Definition	121
Selecting Rooms.....	122
Displaying Rooms	123
Editing Rooms	123
Room Types	124
Room Labels	126
Decks	127
Floor & Ceiling Heights	128
Special Ceilings	129
Room Specification Dialog	131

Chapter 10: Doors

Door Defaults	138
The Door Tools	139

Displaying Doors	141
Editing Doors	142
Changing Door Swings	143
Special Doors	146
Door Specification Dialog	147

Chapter 11: Windows

Window Defaults	155
The Window Tools	155
Special Windows.....	156
Grouped Windows	157
Displaying Windows	159
Editing Windows	160
Bay, Box, and Bow Windows.....	161
Bay, Box, Bow Windows & Roofs	162
Window Specification Dialog.....	164
Bay/Box/Bow Window Specification Dialog.....	169

Chapter 12: Multiple Floors

Floor Defaults Dialog.....	171
Floor Tools	172
Adding Floors.....	172
Displaying Floors.....	173
Deleting Floors.....	174
Stepped Floor & Ceiling Platforms.....	174
Split Levels	174
The Current Floor.....	175
The Attic Floor.....	176
The Reference Floor	176

Chapter 13: Foundations

Foundation Defaults	179
Building a Foundation.....	179
Displaying Foundations.....	180
Editing Foundations.....	181
Deleting Foundations.....	182
Foundations and Rooms.....	182
Foundations and the Terrain	183
Fireplaces.....	184
Fireplace Specification Dialog.....	185
Library Fireplaces.....	187
Chimneys.....	188

Chapter 14: Roofs

Roof Defaults	191
The Roof Tools.....	191
Automatic Roofs	192
Build Roof Dialog.....	192
Editing Roofs	194
Gable Over Door/Window	194
Skylights.....	195
Roof Hole/Skylight Specification Dialog	196
Roof Pitches in Degrees	198

Chapter 15: Stairs & Landings

Stair Defaults.....	205
The Stair Tools.....	205
Anatomy of a Staircase.....	206
Drawing Stairs.....	207

Displaying Stairs and Landings	208
Editing Stairs.....	209
Merging Stair Sections.....	209
Landings	211
Maintaining Tread Depth	212
Starter Treads.....	212
Wrapped Stairs.....	213
Other Special Railings & Stairs	214
Creating a Stairwell.....	215
Rooms Below Staircases	216
Staircase Specification Dialog.....	217
Stair Landing Specification Dialog.....	222

Chapter 16: Electrical

The Electrical Tools	229
Creating Wiring Schematics	230
Auto Place Outlets	230
Electrical Library.....	231
Displaying Electrical Objects.....	231
Editing Electrical Objects.....	231
Electrical Service Specification Dialog.....	232

Chapter 17: Trim Tools

Trim and Molding Defaults.....	237
Corner Boards.....	237
Corner Board Specification Dialog	238
Quoins.....	238
Quoin Specification Dialog	239
Editing Corner Boards and Quoins.....	239
Millwork.....	240

Chapter 18: Cabinets

Cabinet Defaults	242
The Cabinet Tools.....	243
Cabinet Fillers	245
Placing Cabinets.....	245
Displaying Cabinets	247
Editing Cabinets	247
Editing Cabinet Styles.....	248
Special Cabinets	249
Cabinet Specification Dialog	251
Shelf/Partition Specification Dialog	256

Chapter 19: Terrain

Terrain Perimeter	258
Terrain Feature Tools	260
Garden Bed Tools.....	261
Water Feature Tools	261
Terrain Objects in the Library.....	262
Displaying Terrain	262
Editing Terrain Objects	263
Terrain Object Specification Dialogs	263
Terrain Specification Dialog	263
Terrain Feature Specification Dialog	265
Garden Bed Specification Dialog	268
Terrain Path Specification Dialog	268
Plants	269
Plant Image Specification Dialog	269

Chapter 20: Sidewalks, Driveways & Parking Lots

Road Tools	273
Displaying Road Objects.....	273
Editing Road Objects.....	274

Chapter 21: Other Objects

General Shapes.....	276
Soffits.....	276
Special Applications for Soffits.....	277
Calculating Materials on Soffits	278
Soffit Specification Dialog	279

Chapter 22: The Library

The Library Browser	283
Searching the Library	286
Library Content	287
Downloading Library Content.....	288
Importing Library Catalogs	289
Adding Library Content.....	290
Organizing the Library.....	291
Exporting Library Catalogs.....	293
Placing Library Objects.....	293
Select Library Object Dialog.....	295
Displaying Library Objects	296
Editing Library Objects	297
Symbol Object Specification Dialogs	297

Chapter 23: Materials

About Materials.....	300
The Material Painter.....	301
Materials Tab.....	303
Editing Materials.....	304
Creating Materials.....	305
Define Material Dialog.....	306
Material Defaults.....	308
Color Chooser Dialog.....	309

Chapter 24: Zoom & View Tools

Zoom Tools.....	311
Undo Zoom.....	311
Fill Window.....	312
Panning the Display.....	312
Swapping Views.....	313
Window Menu Tools.....	313
Cascade.....	314
Tiling Views.....	316
Arrange Icons.....	317
Closing Views.....	317

Chapter 25: 3D Views

OpenGL and Hardware.....	319
3D Backdrop Dialog.....	319
3D View Tools.....	320
Creating Camera Views.....	321
Creating Overviews.....	321
Elevation Views.....	322

Displaying 3D Views	323
Repositioning Cameras	325
Editing 3D Views	328
Cross Section Slider	330
Working in 3D	331
Printing 3D Views.....	332
Camera Specification Dialog	333

Chapter 26: 3D Rendering

Rendering Tips.....	336
Lighting.....	337
Displaying Lights.....	338
Default Sun Light Specification Dialog.....	339
Glass House View	339
Speeding up 3D View Generation.....	340

Chapter 27: Dimensions

Dimension Unit Defaults	342
Dimension Defaults Dialog	342
The Dimension Tools.....	345
Displaying Dimension Lines	346
Editing Dimension Lines	347
Editing Extension Lines	349
Moving Objects Using Dimensions.....	350
Dimension Line Specification Dialog.....	352

Chapter 28: Text

Fonts and Alphabets	354
The Text Tools.....	355

Creating Text.....	355
Displaying Text	355
Rich Text Specification Dialog	355
Text Specification Dialog	358
Editing Text	360
Copying & Pasting Text	361
Text Arrows	362
Line/Polyline Specification Dialog	363

Chapter 29: Project Planning

House Wizard	366
Plan Check	368

Chapter 30: Pictures, Images, & Walkthroughs

Picture Files vs Pictures and Image Objects	371
Images	371
Displaying Images	372
Editing Images	373
Image Specification Dialog	373
Pictures.....	375
Picture File Box Specification Dialog	376
Metafiles	376
Metafile Box Specification Dialog	377
Displaying Pictures and Metafiles.....	377
Editing Pictures and Metafiles.....	378
Copy Region as Picture	378
Walkthroughs.....	379

Chapter 31: Printing

Introduction to Printing	381
The Printing Tools	382
Display Options and Printing.....	382
Printing Directly from a View	383
Printing to Scale.....	383
Printing Across Multiple Pages	384
Printing to a PDF File.....	385
Page Setup Dialog	386
Print Dialog.....	387
Print Image Dialog	388
Print Model	388

Chapter 32: Materials Lists

The Materials List.....	393
Creating an Accurate Materials List.....	393
Organizing Materials Lists	393
Materials List Display Options Dialog.....	394
Editing Materials Lists.....	395
Exporting the Materials List.....	396
Conditioned Area Totals	396

Appendix A: Additional Resources

Reference Manual	398
User's Guide.....	398
Online Help Videos	399
Home Designer Web Site	399
Home Talk Online User Forum	399
Technical Support.....	399

Upgrade to Chief Architect400

Appendix B: Technical Support Services

Reference and Training Resources402
Troubleshooting Common Technical Issues403
Troubleshooting Printing Problems403
Error Messages.....405
Contacting Technical Support.....406

Program Overview

Home Designer Essentials is designed to help home enthusiasts visualize, develop and share their design ideas. Home Designer Essentials uses parametric design technology, which means that as you draw, a 3D model is created and is updated as you make changes. You can tile a floor plan view next to a 3D view and watch one update automatically as you draw in the other.

Chapter Contents

- Startup Options
- The Home Designer Essentials Environment
- Toolbars
- Menus
- Dialogs
- The Status Bar
- Message Boxes
- Preferences and Default Settings
- Drawing a Plan
- Viewing Your Plan
- Getting Help
- About Home Designer Essentials

Startup Options



When Home Designer Essentials opens, the **Startup Options** dialog displays, allowing you to choose how you want to begin working in the program or access useful resources.

The **Startup Options** dialog can be opened at any time by selecting **File> Startup**

Options

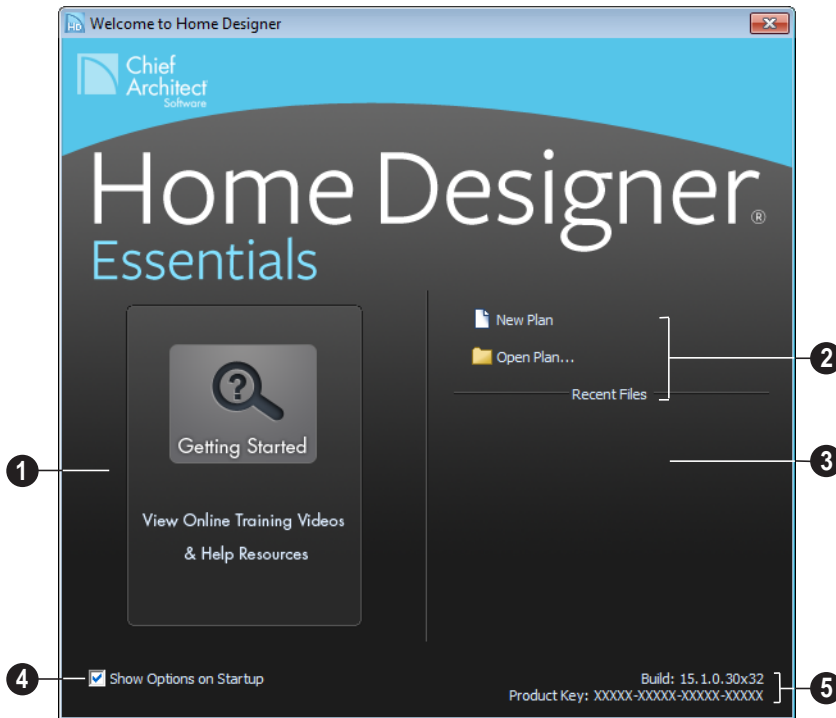

1 Getting Started- Click to launch your default internet browser to the Getting Started page on our web site, www.HomeDesignerSoftware.com. There, you will find links to a variety of online resources to help you begin using the program.

2 Select a **File** command to open a .plan file.

- Click **New Plan** to open a new, blank plan. See “Creating a New Plan” on page 32.
- Choose **Open Plan** to work on an existing plan file. See “Opening and Importing Files” on page 37.

- 3 **Recent Files** lists the names of the most recently opened files. Click on a name to open the file.
- 4 Remove the check from **Show Options on Startup** if you do not want this dialog to display when you launch Home Designer Essentials. Instead, a new blank plan the **Create New Plan** dialog opens.

To have the **Startup Options** dialog display at startup again, select **File> Startup**

Options  and place a check mark at **Show Options on Startup**.

- 5 The **Build** number of the program version you are using and the first five characters of your software license **Product Key** display here.

The Home Designer Essentials Environment

Object-Based Design

Home Designer Essentials's parametric, object-based design technology means you place and edit objects, rather than work with the many individual lines or surfaces used to represent them.

You can quickly select and edit the location, size, shape, style and other properties of objects as well as change the materials applied to their surfaces.

Use Home Designer Essentials's editing capabilities to make the objects you place in a plan match the objects they represent in real life. For example, you can set up your windows and doors to match those available from your supplier.

3D Drafting

In Home Designer Essentials, the entire drawing area is laid out on a Cartesian grid, a three dimensional coordinate system described using the X, Y and Z axes. The current position of your mouse pointer displays in the Status Bar at the bottom of the program window.

Architectural objects take up space in all three dimensions and their height, width and depth can be specified in Imperial or metric units. In addition, the location of objects can be precisely defined using coordinates, again specified in Imperial or metric units.

CAD objects such as lines and arcs take up space in two dimensions in the current view. Their dimensions can also be specified in Imperial or metric units and their locations precisely defined using coordinates.

Easy Access to Tools

You can access Home Designer Essentials's features in various ways using the mouse and keyboard.

- Menus provide access to most tools.
- Convenient toolbar buttons allow fast access to tools and let you customize the interface.
- Keyboard shortcuts are available for most tools.
- Contextual menus display with a right-click of the mouse.

- The Status Bar at the bottom of the screen provides tool descriptions and other information about the current task.

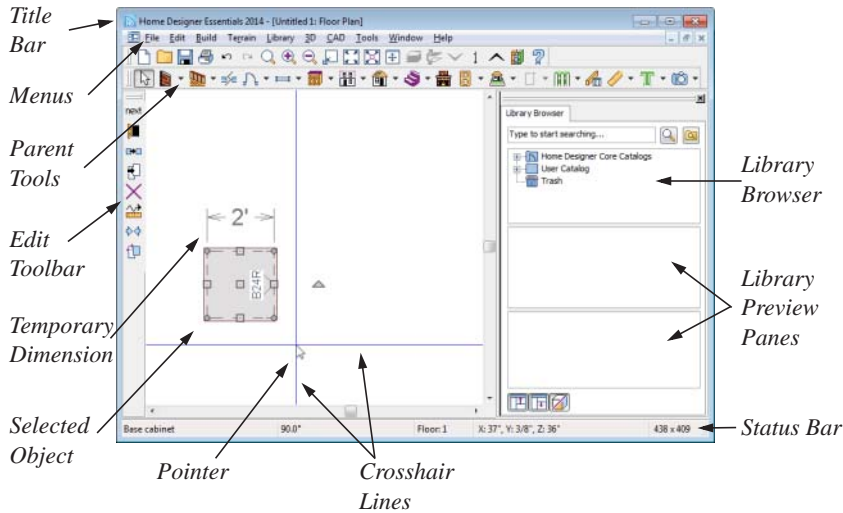

Using the Mouse

Many objects, such as doors and cabinets, are created by clicking the left mouse button. Others, such as walls, stairs and dimension lines, are created by dragging the pointer from one end of the object to the other.



The **left button** is the primary button used in Home Designer Essentials. Unless specified otherwise, Home Designer Essentials documentation refers to the left mouse button.

Note: If you are left-handed and have re-programmed your mouse, reverse the instructions for left and right buttons in this manual.



The **Right button** has several uses. Right-click to select any object.

If, for example, the **Straight Exterior**

Wall  tool is active, the left mouse button allows you to select only walls. You can select other object types such as cabinets with the right mouse button.

You can also use the right mouse button to open a context sensitive menu with additional editing commands.



The **Middle button** can be used to pan in floor plan view

You can also program it to work as a double-click.



The **Mouse Wheel** can be used to zoom in and out in most views.

Using the Edit Handles

When you select an object, its edit handles display.

When you pass the mouse over the edit handles, the pointer changes to show how you can use that handle.

- A two-headed arrow indicates that the object, corner or edge can be moved in the direction of the arrows.
- A four-headed arrow indicates that the selected object or edge may be moved in multiple directions.
- A circular arrow indicates that the selected object can be rotated.

Resize handles display along the edges of the object are used to change the size. See “Resizing Objects” on page 90.



The Move handle at the object’s center lets you move the object. See “Moving Objects” on page 88.

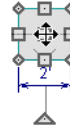

The triangular Rotate handle lets you rotate the object. See “Rotating Objects” on page 92.



You can cancel any edit handle operation before it is completed by pressing the Esc key on your keyboard or by pressing any two mouse buttons at the same time.

The edit handles that display depend on the type of object selected, the current view, and how far you are zoomed out.

Edit handles do not resize as you zoom in or out. If you are zoomed out far enough, some edit handles may be hidden so that they do not stack over one another. As you zoom in, these handles become visible again.

Toolbars

Using the toolbar buttons is the fastest, easiest way to access many program features.

The toolbars that display in a given view depend on the view type. For example, toolbars that control camera position display in 3D views but not in floor plan view.

When you pass the pointer over a toolbar button, a “tool tip” displays the name of the

tool. When you see one of these tool tips, press F1 to get more information about that item. A more detailed description displays in the Status Bar at the bottom of the window.

You can use either of two styles of toolbar interface: drop-down tools or parent-child buttons.

Drop-Down Tools

Click on the arrow to the right of a button to display a drop-down list of related tools. For example, click the arrow to the right of the

Window  button to display a drop-down list of the other Window Tools.

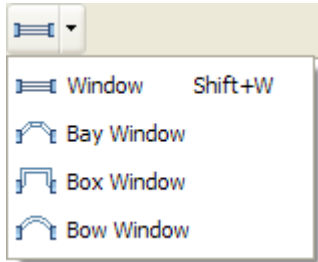

The most recently selected tool displays in the toolbar.

Parent and Child Tools

An alternative to the Drop-Down toolbar interface are Parent and Child tools. Parent toolbar buttons have a blue triangle in the lower right corner. When you select a parent button, child tools display on the right side of the toolbar.

When you click the **Window Tools**  parent button, for example, its child buttons display to the right.



You can select either Parent-Child or Drop-Down tools in the **Preferences** dialog. See “Appearance Panel” on page 50.

The Edit Toolbar

When you select an object, the edit toolbar appears. By default, it is located at the of the program window. The toolbar buttons that display can be used to edit the selected object(s). Which buttons display depends on the type of object selected, the current view, and how you selected the object.

The edit toolbar buttons are the same as the options in the contextual menu when you right-click on an object.

Hotkeys

Many commands can be invoked from the keyboard. Press Alt on your keyboard and press the underlined letter in a menu name to access that menu, as well as items in the menus and submenus.

Other keys or key combinations will invoke a variety of program commands. If a Home Designer Essentials menu item has a keyboard shortcut, or hotkey, associated with it, that hotkey will display to the right of its name in the menu.

Menus

Home Designer Essentials uses a standard Windows menu format. The menus are located below the title bar in the program window and can be used to access nearly all

tools in the program. Click on a menu name to expand it, then click on a menu item to either activate that tool or access the item’s

submenu. Items with a submenu have an arrow to the right of the name.

Menu items with an icon to their left have a toolbar button associated with them.

The menus can be accessed using the keyboard. Press the Alt key once to enable this functionality - one letter in each menu will become underlined. Press the key associated with one of these underlined letters to expand its menu - one letter in each menu item's name will be underlined. Press the key associated with one of these letters to activate that tool or access the item's submenu. Press the Esc key to undo your last selection, or click with the mouse to exit out of this functionality.

Many tools in Home Designer Essentials also have hotkeys associated with them. If a menu item has a hotkey, it will display to the right of the item's name. See "Hotkeys" on page 57.

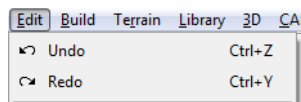

Edit menu items with button icons to the left and hotkeys to the right

In the Home Designer Essentials documentation, menu paths are written in this format: **Build> Window> Box**

Window . An icon image after the menu path indicates that a toolbar button is also available.

Contextual Menus

Contextual menus are context sensitive menus that display tools relevant to a selected object or view.



To access contextual menus, right-click on an object, in an empty space in a view window or in a text field in any dialog box.

Contextual menus can be enabled or disabled in the **Preferences** dialog. See "Appearance Panel" on page 50.

Dialogs

Default settings, object specifications, display settings, and many other functions are accessed through dialog boxes.

Dialog tabs and settings can be accessed using the mouse. You can also navigate the settings on a given dialog tab using the keyboard:

- Press the Tab key proceed from one setting to the next, or Shift + Tab to go in the reverse direction.
- Line items in tree lists can be browsed using the arrow keys. Up and Down navigate the list, while Left and Right expand and contract categories.
- Settings with spin control arrows  can be adjusted by typing in the text field, using the up and down arrow keys, or the mouse scroll wheel.
- Settings with slider bars  can be adjusted by typing in the text field, using

the left and right arrow keys, or the mouse scroll wheel.

- Press Enter on your keyboard to close any dialog and apply your changes.

Many dialogs have a preview that shows how the changes affect the object. This preview updates when you click in a different field or press the **Tab** key on your keyboard.

Some dialog boxes are resizable. Resizable dialogs have a size grip at the lower right corner of the box which you can click and drag.

Specification Dialogs



Each object in Home Designer Essentials has a unique specification dialog where you can enter size, style and other information specific to the selected object. To access it, select the object and click the **Open Object** edit button. You can also double-click on an object with the **Select**

Objects  tool active to open its specification dialog. See “Selecting Objects” on page 71.

The Status Bar

The Status Bar at the bottom of the main program window displays information about the current state of the program.

This information depends on a variety of conditions such as the type of object selected, and the current position of the pointer. The information may include the following:

- A brief description of the toolbar button or menu item highlighted by the mouse.
- A description of the selected object.
- The total number of objects currently group-selected.
- Basic information about a selected library object, folder, or catalog.
- The current floor.
- The screen redraw time.
- The length and/or angle of an object as it is being drawn.

Message Boxes

As you work in Home Designer Essentials, the program will alert you if you command it to do something that could potentially cause a problem, or if the program encounters a problem that needs your attention.

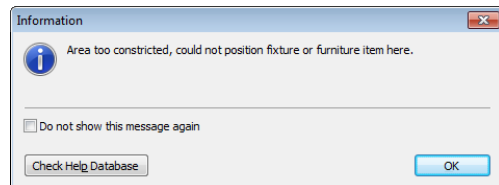

Situations where such message boxes may display include:

- Closing a file without saving;
- A file referenced outside the program, such as an image or texture, is missing;
- Creating an object in a space too small to contain it.

You can access the settings in a message box using the mouse, or navigate them using the keyboard:

- Press the Tab key proceed from one setting to the next, or Shift + Tab to go in the reverse direction.
- When a checkbox is the active setting, press the Spacebar to check or to clear it.
- Buttons have hotkeys associated with them. Press the Alt key on the keyboard

to underline the hotkeys in the current message box.

- Press Enter on your keyboard to close the message box and perform the action associated with the highlighted button.

Some message boxes include a “Remember my choice” or a “Do not show this again” checkbox. Check this box to prevent messages of this specific type from displaying in the future.

To allow all message boxes to display again, click the **Reset Message Boxes** button in the **Preferences** dialog. See “Reset Options Panel” on page 55.

Preferences and Default Settings

Preferences and default settings control many aspects of the user interface and tool behavior in Home Designer Essentials. You can use these settings to customize the program to suit your personal work style.

For more information about defaults and preferences, see “Preferences & Default Settings” on page 46.

Preferences



Preference settings let you change program behavior to suit your workflow. For example, you can:

- Turn certain display elements on or off.
- Choose background and editing feedback colors.
- Set rendering specifications to maximize efficiency and quality.

Preference settings are global, affecting all plan files.

Defaults

Most objects in Home Designer Essentials derive their initial properties from their respective default dialogs.

For example, a newly placed **Window**  gets its initial values from the **Window Defaults** dialog and a newly placed **Hinged Door**  gets its initial values from the **Door Defaults** dialog.

Once an object is placed in a plan, its initial properties can be overridden, but setting up your defaults before you begin drawing can save you considerable time as you build a model in the program.

Default settings, unlike Preferences, are file specific.

Dynamic Defaults

Most default settings are static: if you change one, any objects of that type in the current

file will not be affected. A few defaults, however, are dynamic: they are tied to existing objects in the drawing and if you change the default, those objects may be affected. See “Dynamic Defaults” on page 48.

Drawing a Plan

When you draw a plan in Home Designer Essentials, you are placing 3D objects that represent building components. Home Designer Essentials comes with predefined default settings so you can start drawing plans immediately. You should review these default settings to be sure they match your drawing and building methods. See “Preferences & Default Settings” on page 46.

Set the Defaults

Set material defaults for roof, walls, and rooms.

Set style defaults for doors, windows, cabinets and other objects.

Draw the Floors

1. While the size of the drawing area in Home Designer Essentials is limited only by the resources on your computer, it is best to begin your drawing near the origin, 0,0,0. See “3D Drafting” on page 18.
2. Draw the exterior walls on Floor 1. See “Drawing Walls” on page 103.
3. Adjust the perimeter shape and size as required. See “Using the Edit Handles” on page 107.

4. Place any first floor bearing walls.
5. Define types for special rooms such as garages and decks in the plan. See “Room Types” on page 124.
6. Place perimeter doors and windows. See “Doors” on page 138 and “Windows” on page 154.
7. Build additional floors. See “Adding Floors” on page 172.
8. Specify the default ceiling height for each floor as soon as it is created. See “Floor Defaults Dialog” on page 171.
9. Adjust the perimeter shape of additional floors as needed. See “Editing Walls” on page 107.
10. Align edited or moved walls with those above or below where appropriate. See “Aligning Walls” on page 110.

Entering Dimensions

When using Imperial units, enter distances as inches or feet and inches, in fractional or decimal form. Millimeters are the default unit for all metric distances. See “Dimensions” on page 342.

- To enter feet, include the (') marker or the program assumes inches.

- In most cases, the program allows precision to 1/16th of an inch. Fractions with denominators 2, 4, 8 and 16 are allowed.
- The program usually converts decimals to fractions.

Build the Foundation

1. Derive the foundation plan from the first floor. See “Building a Foundation” on page 179.
2. Adjust the foundation perimeter shape as needed.
3. Place interior foundation walls as needed for the first floor bearing walls.
4. Place any other foundation walls required.

5. **Align with Above** as needed. See “Aligning Walls” on page 110.

Add Structure and Details

1. Build non-structural interior walls. Begin on floor one and work up in multiple story structures.
2. Add walls where needed to create features such as chimney chases, plumbing walls, or Open Below areas.
3. Finish the relevant interior structure including interior doors, doorways, cabinets, fixtures, and fireplaces.
4. Build the terrain and landscaping. See “Terrain” on page 258.

Viewing Your Plan

You can see your model in a variety of different 2D and 3D views. You can display more than one view at a time; and in any view, you can pan or zoom in or out. See “Zoom & View Tools” on page 310.

Floor plan view is a 2D view of the model and is most commonly used for drawing and editing. In floor plan view, each floor displays separately and you can only edit one floor at a time; however, you have extensive control over which objects display at any given time, can easily switch between floors, and can also display items on a second floor for reference.

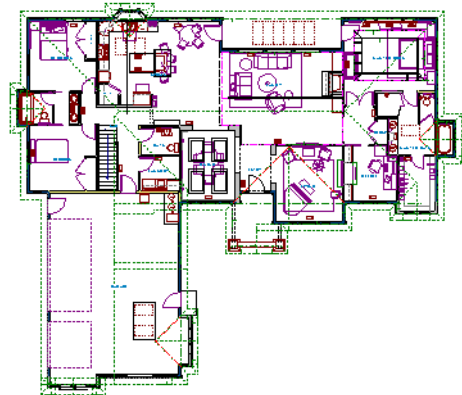

You can create interior and exterior 3D views of your model from any perspective. As in floor plan view, you can select and edit many objects in 3D views and control which objects are visible. See “3D Views” on page 318.



You can also create **Doll House Views** that show only the current floor plus any floors beneath it. Ceilings on the current floor are omitted so you can see the interior, visualize the relationships between spaces, and plan traffic flow.



Framing Overviews display framing in 3D. You can customize 3D views to serve special purposes such as this.

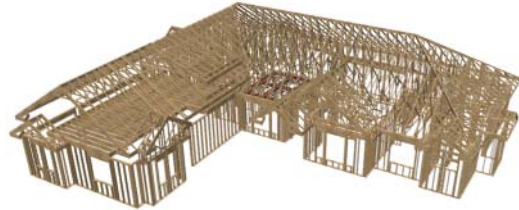

All views can be exported as a graphic image. See “To export a picture” on page 375.

Getting Help



There are many forms of help available in Home Designer Essentials including: Tool Tips, the Status Bar, and the online Help menu.

All these forms of help assume you have a basic working knowledge of the Windows® operating system, including how to use a mouse, open, close and save files, copy, paste, and right-click to access contextual menus. Help also assumes you are familiar with Windows® terminology.

More information is available in the product documentation in electronic format and on Home Designer’s official web site,

www.HomeDesignerSoftware.com. See “Additional Resources” on page 398.

Tool Tips

When you move the pointer over a toolbar button or menu item, a **Tool Tip** displays, offering a brief description of the tool. More information displays in the Status Bar at the bottom of the window.

Online Help Menu

Online **Help** is a searchable menu that provides information about all of the tools in Home Designer Essentials. Select **Help>**

Contents & Index  to open the online

Help and explore the table of contents, browse the Index, or search for keywords.

Current Mode Help

Online Help can also be used to provide instant information about toolbar buttons, menu items, and objects in your plan.

- When you move the cursor over a toolbar button or menu item, a brief summary of that tool displays in the Status Bar. Press the F1 key to open online Help to a page with more information about the tool.

- When an object is selected, edit handles display. Place the cursor over an edit handle and press **F1** to open online Help to a page with information about that handle.
- Press the **Help** button in any dialog box to open online Help to a page describing the options in that dialog.

Chief Architect strives to make our documentation as helpful as possible for all of our customers. Please send any questions, comments, or feedback to documentation@chiefarchitect.com.

About Home Designer Essentials

Select **Help> About Home Designer Essentials** to view information about your software license, the program's version number, and its release date.

Contact information for Chief Architect, Inc. is available on the **More Information** tab.

Upgrade to Chief Architect

Select **Help> Upgrade to Chief Architect** to launch your default web browser to the Chief Architect web page, www.chiefarchitect.com, where you can learn about this powerful home design software for building professionals.

Chief Architect can open plans originally created in Home Designer, and offers an extensive set of drawing, editing and rendering tools that allows you to produce complete, professional working drawings.

File Management

Home Designer Essentials saves the complete 3D model of a structure and surrounding terrain as well as text in **.plan** files.

All commands related to opening, saving and closing plans are located in the File menu. You can also open plans from the **Startup Options** dialog. See “Startup Options” on page 17.

Just as with files created in other software applications, you should back up your plan files externally on a regular basis to avoid accidental loss of work.

Chapter Contents

- Compatibility with Other Programs
- Organizing Your Files
- Home Designer Essentials Data
- Creating a New Plan
- Saving, Exporting, and Backing Up Files
- Auto Archive
- Undo Files
- Opening and Importing Files
- Searching for Plans
- Backup Entire Plan
- Closing Views and Files
- Exiting Home Designer Essentials

Compatibility with Other Programs

Plans produced in the following programs can all be read by Home Designer Essentials 2014.

- Chief Architect® X1 through X4 (limited editability if enabled)
- Chief Architect® 5.0 through 10.08 (read only)
- 3D Home Architect® 3.0 and 4.0
- Chief Architect® Home Edition 5.0
- All Better Homes and Gardens Home Designer® products, Interior Designer, and Landscaping and Deck Designer, Versions 6 through 8.
- All Chief Architect Home Designer® products, Interior Designer, and Landscaping and Deck Designer, Versions 9 through 2014.

- Trading Spaces® Design Companion™

Note: 3D Home Architect 5.0 was not developed by Chief Architect, Inc. Plans written using 3D Home Architect 5.0 or later cannot be read by Home Designer Essentials.

Files that have been opened and saved in Home Designer Essentials 2014 cannot be read by any of the program versions listed above. To continue to read files in the program in which they were created, be sure to create copies of your files before opening them in Home Designer Essentials 2014.

Plans created in Chief Architect, build 11.4 and later, can be opened in Home Designer programs for viewing and annotating only. Limited editability in Home Designer programs is an option that can be enabled when the file is opened in Chief Architect.

Organizing Your Files

You should keep your plan files separate from the support files needed to run Home Designer Essentials. To keep files organized, you may find it helpful to create a new folder for each project.

Home Designer Essentials files may use imported images, textures and other custom content saved in their own external data files. Consider storing copies of all external files in the same folder as the plan files that use them so that they are easily found.

Here is one way to organize your files:

- Create a folder in your Documents directory (“My Documents” in Windows XP) called “Home Designer Essentials Plans” or another name you prefer. See Microsoft Windows Help to learn how to create folders.
- Inside this folder, make a new folder for each project. Save all the files for that project inside this folder, including plan files and referenced external files. See “Saving, Exporting, and Backing Up Files” on page 33.

Bear in mind, though, that path names exceeding 260 characters cannot be opened

by Home Designer Essentials. As a result, it is a good idea to limit the number of embedded folders you use in your file organization method.

Once you understand the file management of Home Designer Essentials, you can decide on a naming convention that suits your needs.

Home Designer Essentials Data

When Home Designer Essentials 2014 is installed, the program automatically creates a folder in the user Documents directory called **Home Designer Essentials 2014 Data**. This folder contains important user-specific information saved in the following folders and files and should not be moved, renamed or deleted:

- **Archives** - A folder of automatically archived plan files. See “Auto Archive” on page 36.
- **Backdrops** - A folder of custom backdrop images. See “3D Backdrops” on page 324.
- **Images** - A folder of custom images. See “Adding Materials and Images” on page 290.
- **Database Libraries** - A folder of user library data. See “Library Content” on page 287.
- **Scripts** - A folder for custom Ruby scripts associated with Chief Architect plans.

- **Templates** - A folder of plan template files. See “Creating a New Plan” on page 32.
- **Textures** - A folder where you can save image files used to create custom material textures. See “Creating Materials” on page 305.
- **Toolbars** - A folder of toolbar files. See “Toolbar Arrangement” on page 57.



If the Home Designer Essentials 2014 Data folder is renamed, moved or deleted, the program will automatically replace it using default information from the Home Designer Essentials installation folder. When this occurs, customized user settings and custom user library content will not be available.

Because the Home Designer Essentials 2014 Data contains custom user data, it is not deleted when the program is uninstalled. See “Uninstalling Home Designer Essentials” on page 21 of the User’s Guide.

Creating a New Plan



To open the **Create New Plan** dialog, select **File> New Plan**.

You can also choose **New Plan** in the **Startup Options** dialog. See “Startup Options” on page 17.

Template Plans



When you select **File> New Plan** in Home Designer Essentials, the **Create New Plan** dialog opens, letting you select a template for your new plan. The resulting

new plan uses either metric or Imperial units of measurement and predefined default

settings, layer settings, wall definitions, and page setup information.

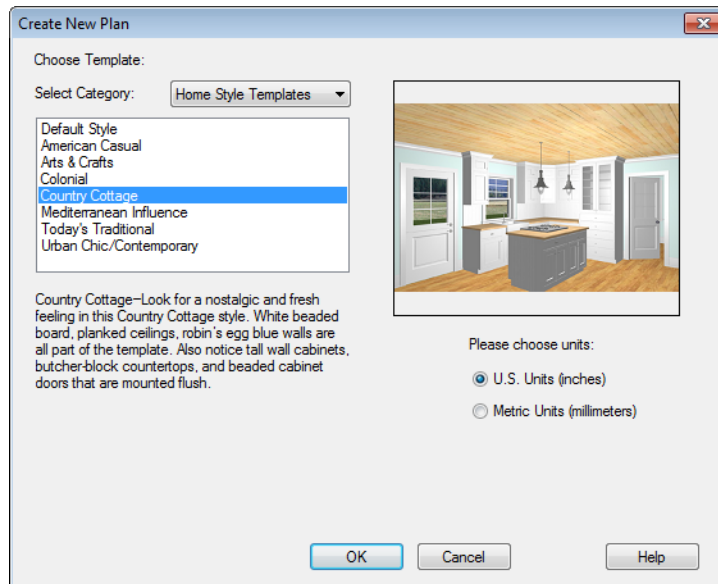

Home Designer Essentials includes a selection of plan templates, each with different default settings that allow you to begin working in a particular plan style quickly. See “Default Settings vs Preferences” on page 47.

Select a style template from the scrollable list. If you are uncertain as to the right style for your plan, choose Default, as you cannot

change the plan style template once a plan has been created.

Select either **U.S. Units** or **Metric Units** of measurement, and click **OK**. The floor plan view window opens, ready for you to begin drawing.

New, blank plans are called **Untitled.plan**. Unless these files are named and saved, they will be lost when closed.

Saving, Exporting, and Backing Up Files

Saving, exporting, and backing up your files are three separate tasks that accomplish different things:

- Saving a plan file retains your work so that it can be later opened in Home Designer Essentials.
- Exporting a file allows you to save certain kinds of data in a format that can be used

by a program other than Home Designer Essentials.



- Backing up your files involves taking steps to make sure that your valuable data is protected and available when needed.



Saving Plan Files



When you first save a new, untitled file, you must select a location for it on your computer and give it a name. There are two options for saving plan files: **File> Save** and **File> Save As**.

 Although the program warns you if you try to exit without saving, you should get in the habit of saving plan files before exiting the program.

Both **Save**  and **Save As**  can be used to save your plan files; however, they accomplish this in two different ways.



- **File> Save**  saves the current state of your plan file without changing its name and should normally be used for saving your work.
- **File> Save As**  opens the **Save Plan File** dialog, allowing you to save the plan file using a different name or location on your computer.

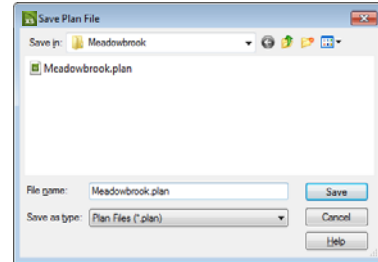

To save an untitled plan file

1. Select **File> Save**  to open the **Save Plan File** dialog.



2. In the **Save in** drop-down, browse to the location on your computer where you would like to save the file. See “Organizing Your Files” on page 31.
3. In the **File name** text field, type a name for the file.
4. Home Designer Essentials automatically assigns the **File of type** and file extension **.plan**.
5. When both the Save in location and File name are correct, click **Save**.

Initially, all **Open**  and **Save As**  operations go to the “My Documents” folder of your computer. After that, the location last visited is remembered and subsequent

Open  or **Save As**  commands default to the directory last used for that operation. This path is saved when the program exits. The next time Home Designer Essentials is launched, these defaults are used.

Exporting Files

Home Designer Essentials has a number of options for exporting and importing information out of and your drawings. Often, file export dialogs are nearly identical to the **Save Plan File** dialog. See “Pictures, Images, & Walkthroughs” on page 370.

Similarly, file import dialogs are often similar to the **Open Plan File** dialog. See “Importing Files” on page 38.

Revision Files

Revisions are a common aspect of any design project. There are a number of possible strategies for organizing revision files:

- Prepending the file name;
- Appending the file name;
- Saving revisions in separate folders.

To avoid confusion and potential mistakes, it is recommended that you always give files unique names - including revision files. If you choose to organize your revisions by saving them in separate folders, you should also give each file a unique name that makes it impossible to confuse it with another file saved in a different folder.

Backup Entire Plan

File > Save As  is a simple way to transfer a plan to a different location on your computer. Bear in mind, though, that plan files often reference external data files such as imported textures, images, and backdrops. These external files are not affected when

Save As  is used.

If you transfer a plan file from one computer to another, the program will warn you of missing files if the external data files used by the plan cannot be found when you open it.

When transferring plans to another computer that does not have these external files, use the **Backup Entire Plan**  tool. See “Backup Entire Plan” on page 42.

Backing Up Your Files

It is always a good idea to create backup copies of all your important files on your computer.

It is strongly recommended, however, that you never save directly onto removable media such as a USB thumb drive, CD, or DVD. Instead, copy your files to such locations in Windows Explorer only after you have saved them on your computer’s hard drive and exited the program.

Archive folders are used by Home Designer Essentials to manage prior versions of your files. You should not view these files as a substitute for your own backup routine, and should never save a file in an archive folder. See “Auto Archive” on page 36.

When backing up your Home Designer Essentials files, consider backing up not only your **.plan** files, but your custom user data, as well - including library content, toolbar configurations, and textures. This custom data is all located in the Home Designer Essentials Data folder, so it can be easily backed up. See “Home Designer Essentials Data” on page 32.

You can, if you wish, create a folder inside the Data folder for your **.plan** files, as well. See “Organizing Your Files” on page 31.

Auto Archive

The first time a plan is saved, Home Designer Essentials creates an Archive folder in the Home Designer Essentials Data folder. The Archive folder contains Auto Save and Archive files.

The program does not create Auto Save and Archive files for untitled plans. In order for these to be created, a file must have been previously saved and given a name and save location on your computer. Further, Archive files are only updated when you save your work.

Auto Save and Archive files should not be viewed as a substitute for regularly saving your work by selecting **File> Save**  or pressing Ctrl + S on the keyboard, nor should they be considered an alternative to your own file backup routine.

Archive Files

Every time a drawing is saved, Archive files that keep a historical archive of your plan are automatically created or updated.

 If you do not save your work regularly, your archive files will not be updated.

Plan files from previous versions of the program are automatically moved to the archive folder when the plan is opened and saved in Home Designer Essentials.

Archive files are meant to be for emergency use only. If you must access an archive file, open it as you would any other file. See “Creating a New Plan” on page 32. As soon

as the file is open, use **Save As**  to save this file to another location.

Auto Save Files

As you work, Home Designer Essentials automatically creates Auto Save files at regular intervals when changes are made to a file but not saved by selecting **File>**

Save .

These Auto Save files are appended **_auto_save.plan** and are saved in the Archive folder.

When you close a file normally, its Auto Save file is retained until the next time the file is opened - at which time the Auto Save file is overwritten.

 JonesResidence_auto_save.plan

Auto Save file after normal shut-down

Auto save files created as a result of an improper program shutdown are appended **_auto_save_bak.plan**.

 JonesResidence_auto_save_bak.plan

Auto Save file after abnormal shut-down



If your computer shuts down accidentally, you can recover some of your work by opening the **_auto_save_bak** file.

 A file is auto saved only if you have saved it previously. Auto Save does not work for unnamed files.

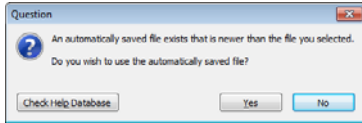
When you reopen a file after a computer shut down or system crash, the following dialog displays if an Auto Save file newer than the original file is found.



Even with Auto Save, you should save your work manually on a regular basis using any of the following methods:

- Click the **Save**  button.
- Select **File> Save** .
- Press Ctrl + S on the keyboard.

Undo Files

Home Designer Essentials stores a set number of copies of all open plan file changes, known as undo files. Undo files are referenced whenever you select **Edit>**

Undo  or **Edit> Redo** . See “Undo and Redo” on page 94.

Undo files are stored in the Windows Temporary Directory. When you use Windows system cleanup features, these files can be deleted. Because of this, you should only use these type of utilities when Home Designer Essentials is not running.

When Home Designer Essentials is closed normally, any current Undo files are deleted.

Opening and Importing Files

Opening and importing files are often similar tasks, but accomplish two very different things:

- Opening a file refers to opening it in the program in which it was created. Only plan files can be opened in Home Designer Essentials. See “Compatibility with Other Programs” on page 31.
- Importing a file brings data that was created in a different program into Home Designer Essentials. A number of different file types can be imported into Home Designer Essentials.

 Select **File> Open Plan** to open an existing **.plan** file located on your computer. Home Designer Essentials automatically browses to the directory last used.

 Never open a file located on a server or other computer on a network, or on a removable storage device. Copy such files to your local machine's hard drive first, and then open the copy.

The **Open Plan File** dialog can be resized by clicking and dragging the lower right corner.

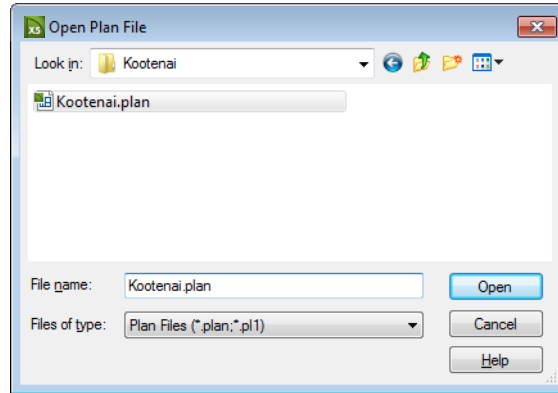

- In the **Look in** drop-down, browse to the location on your computer where the file you wish to open is saved.
- Any folders and **.plan** files in the current location display in the field below. The file type that displays depends on the Files of Type selection.
- Click on the file you wish to open. Its name will display in the **File name** text field.
- The only file type available in the **Files of type** list is **.plan**.
- When the desired file is selected, click **Open**.

Plan files open to the floor that was active when the file was last saved and closed.

Importing Files

Home Designer Essentials has a number of options for exporting and importing information out of and into your drawings. Often, file import dialogs are nearly identical to the **Open Plan File** dialog. See “Pictures, Images, & Walkthroughs” on page 370.

Similarly, file export dialogs are often similar to the **Save Plan File** dialog. See “Exporting Files” on page 34.

Recently Opened Files

The names of the plan files you most recently opened or saved display at the bottom of the **File** menu. Click on a recent file to open that file without using the **Open Plan File** dialog.

The names of recently open files also display in the **Startup Options** dialog. Click on the name of a file to open it. See “Startup Options” on page 17.

Searching for Plans



Select **Tools> Plan Database> Search for Plans** to locate an

existing, fully-editable sample plan or search a selection of non-editable plans by popular

home designers. This command opens the **Find Plan Wizard**, which helps you search

for plans based on parameters that you define.

Find Plan Wizard

The **Find Plan Wizard** can be used to search for plans using stored information about each

plan, such as the square footage and the number of bedrooms and other room types.

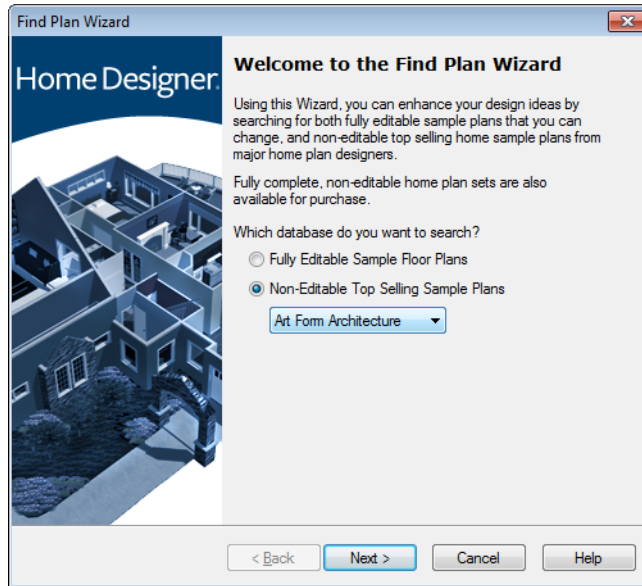

Begin by selecting either a database of editable sample plans or a collection of house

plan drawings by popular home plan companies, then click **Next** to continue.

House Style

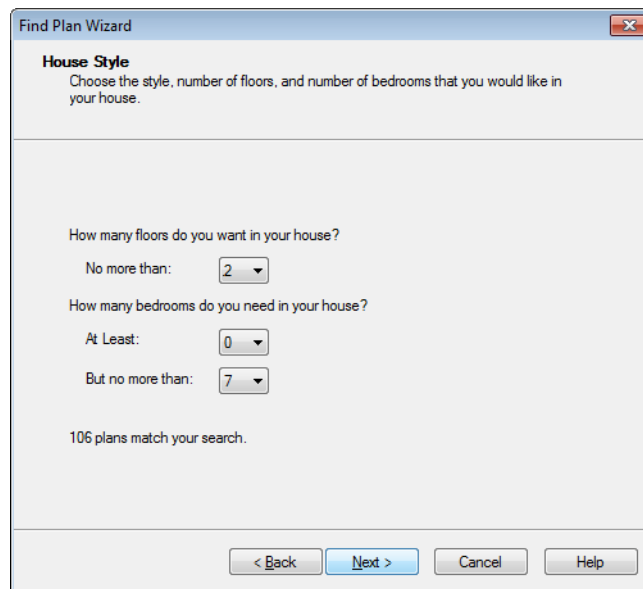

The screenshot shows a window titled "Find Plan Wizard" with a close button in the top right corner. The main heading is "House Style" with a sub-instruction: "Choose the style, number of floors, and number of bedrooms that you would like in your house." Below this, there are two sections of input fields. The first section asks "How many floors do you want in your house?" with a "No more than:" label and a dropdown menu showing the number "2". The second section asks "How many bedrooms do you need in your house?" with "At Least:" and "But no more than:" labels, and dropdown menus showing "0" and "7" respectively. At the bottom of the main content area, it says "106 plans match your search." At the very bottom of the window, there are four buttons: "< Back", "Next >" (highlighted in blue), "Cancel", and "Help".

At the bottom of each page, the number of plans that match your current search parameters displays. As you modify the parameters, this number increases or decreases as matching plans are found.

On any page, click the **Back** button to modify any previously selected parameters.

Select the number of floors in the house and the number of bedrooms, then click **Next** to continue.

House Size

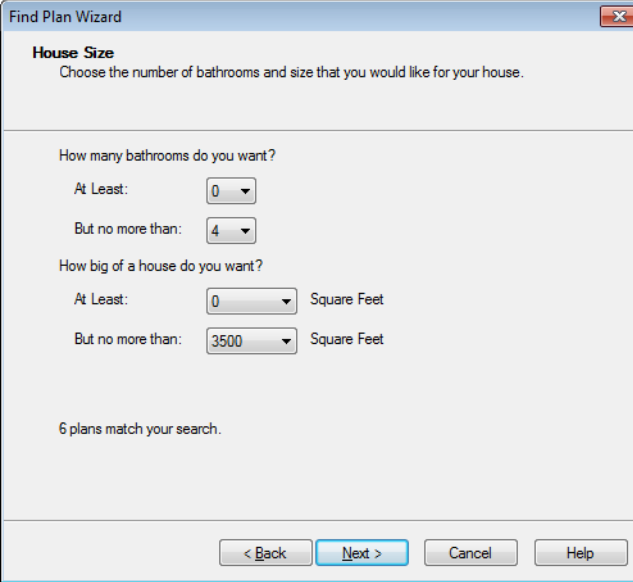

The screenshot shows a dialog box titled "Find Plan Wizard" with a close button in the top right corner. The main heading is "House Size" and the instruction is "Choose the number of bathrooms and size that you would like for your house." Below this, there are two sections of input fields. The first section is titled "How many bathrooms do you want?" and contains two dropdown menus: "At Least:" with the value "0" and "But no more than:" with the value "4". The second section is titled "How big of a house do you want?" and contains two dropdown menus: "At Least:" with the value "0" and "But no more than:" with the value "3500", both followed by the text "Square Feet". At the bottom of the dialog, it says "6 plans match your search." and there are four buttons: "< Back", "Next >" (highlighted in blue), "Cancel", and "Help".

Select the number of bathrooms and square footage of the house, then click **Next** to continue.

Plan Details

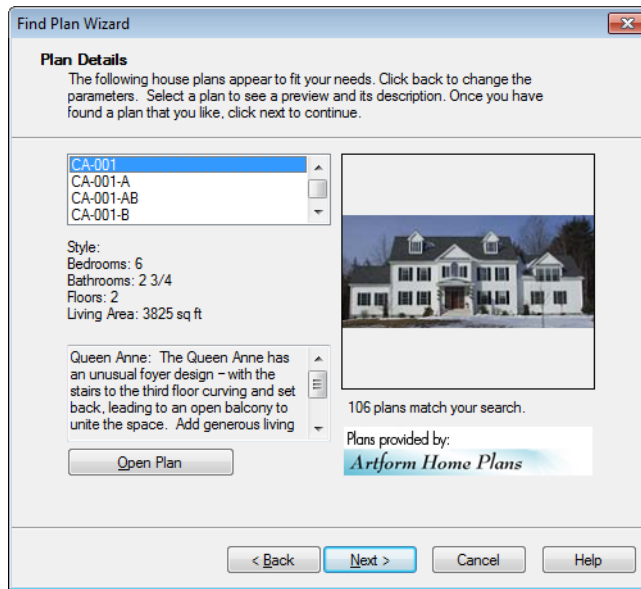

Click on the name of a plan in the list to see a preview of the plan

Click **Next**, then click the **Finish** button to open the selected plan.

Backup Entire Plan



Because Home Designer Essentials plans often contain many references to other external files, it is necessary to copy all the associated files to a new location when a plan is moved. You can do this easily by selecting **File> Backup Entire Plan**.

Backing up an Entire Plan is important when:

- Migrating legacy files created in older program versions.
- Transferring files to another computer or sending them to another user.
- Archiving or backing up your work.

To back up a plan

1. To copy all associated plan files to a new directory, select **File> Backup Entire Plan** . The **Backup Entire Plan** dialog opens for you to choose what files are copied.

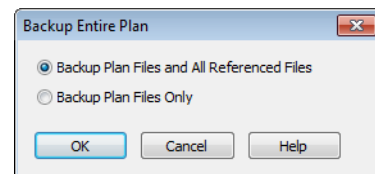

- Choose **Backup All Files** to copy all plan files and all externally referenced files such as linked plan files, inserted picture files, metafiles, and texture, image, and backdrop graphics files.
 - Choose **Backup Plan Files Only** to copy all associated plan files and any externally linked files and inserted picture files, but no graphics or texture files. This is best used only when transferring a file to a computer that already has the graphics files installed.
2. When you click the **OK** button in the **Backup Entire Plan** dialog, the **Browse for Folder** dialog opens. Here you can select the destination folder for the associated plan files.

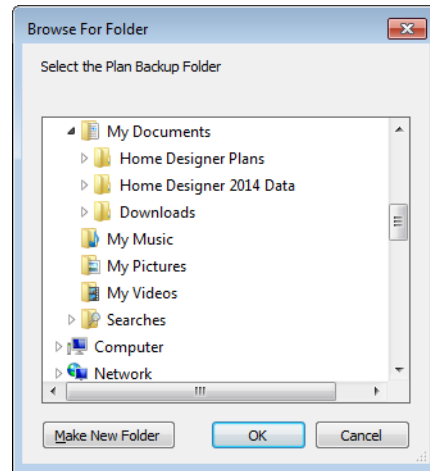

3. Navigate to any empty folder on your system and click on it to select it.
- To create a new folder, click on a folder already present on your system, then click the **Make New Folder** button.
4. With the destination folder for the backup selected, click **OK**.

 You must select an empty folder for the Backup Entire Plan feature to work. If you select an existing folder that is not empty, the backup is cancelled.

Closing Views and Files

Choose **File> Close** to close the active window. If it is the last open view for a plan and you have not saved it, the program prompts you to save before closing.

Select **File> Close All** to close all currently open windows.

 Although the program warns you if you try to exit without saving, you should get in the habit of saving plan files before exiting.

Exiting Home Designer Essentials

Select **File> Exit** to exit the program. If you have not saved any open plans, you are reminded to do so. It is better to save your work before exiting than to save on exit.

When you exit from the program using **File> Exit**, all Autosave files and Undo files are automatically deleted.

Preferences & Default Settings

Preferences are global settings that affect the functionality and appearance of the Home Designer Essentials environment, while default settings control what objects look like when they are initially created. You can save time by becoming familiar with these settings and customizing them before you begin a new drawing.

Chapter Contents

- Default Settings vs Preferences
- Dynamic Defaults
- General Plan Defaults Dialog
- Preferences Dialog

Default Settings vs Preferences

Default and preference settings have important effects on how the tools in Home Designer Essentials function. Default settings are file specific, while Preferences are global, taking effect regardless of what file is open.

Defaults and Preference settings can be customized to suit your needs and improve your efficiency, so it is recommended that you become familiar with them and learn how you can use them to your advantage.

Default Settings



Default settings determine the initial characteristics of objects when they are first drawn. For example, when you place a base cabinet in a plan, its size, materials, front items, hardware are determined by settings in the **Base Cabinet Defaults** dialog.

Defaults are file-specific, which means that any changes that you make to the default settings in one plan file will have no effect on other plans.

You can access a complete list of the various default settings by selecting **Edit > Default Settings**  from the menu.

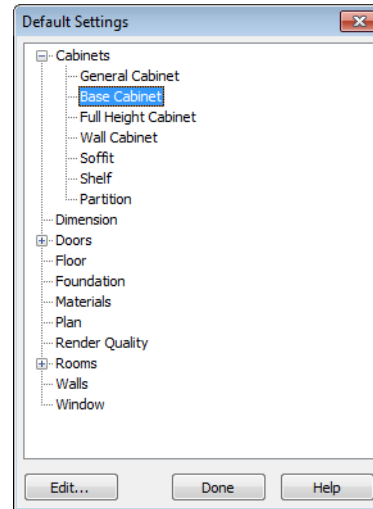

- Click the + beside a category to expand it and access the defaults for items related to that category.
- To open the defaults dialog associated with an item in the list, double-click on the line item, or click on the item and then click the **Edit** button.

Preferences



Preference settings influence the overall environment of the program, such as what the interface looks like and how the tools are accessed. See “Preferences Dialog” on page 49.

Unlike default settings, preferences are global, which means that any changes that you make to them will take effect in all plan files.

To access the **Preferences** dialog, select **Edit > Preferences**  from the menu.

Dynamic Defaults

Dynamic defaults are values that can be changed globally throughout a model.

- If you change a dynamic default value in a defaults dialog, all objects of that type that are set to use the default will update automatically to use the new value.
- Any objects of that type that are not using the default value because of editing will not be affected if you change the default.

Dynamic defaults are found in the default dialogs of a variety of objects, including dimension lines, walls, doors, cabinets and rooms.

Materials are another example of an attribute that uses Dynamic Defaults. See “Material Defaults” on page 308.

In object specification dialogs, dynamic defaults are followed by either a (D) in the value field or a Default check box.

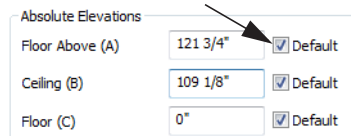

To edit a dynamic default, delete the (D) or remove the check from **Default** box and type the desired value.

To reset a value back to the dynamic default, type the letter D in the field or click the Default checkbox.

General Plan Defaults Dialog

The settings in the **General Plan Defaults** dialog control basic features of the Home Designer Essentials environment. To open

this dialog, select **Edit > Default Settings** , select **Plan**, and click the **Edit** button.

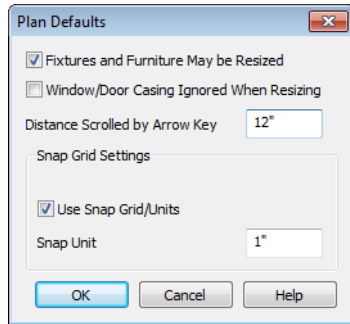

- Check **Fixtures and Furniture May be Resized** to display side edit handles on selected fixtures and furniture so you can resize them. Clear this option to display only Move and Rotate edit handles. See “Editing Box-Based Objects” on page 82.

Changes made to fixture/furniture sizes are not reflected in the Materials List because the Materials List refers to objects by their labels, not by their physical dimensions. If you resize a fixture or

furniture object, the correlation between its label and its actual physical dimensions is no longer accurate.

- Casing is the trim that surrounds a door or window. When you resize a door or window, its sides are kept away from intersecting walls by the width of the casing. Check **Window/Door Casing Ignored When Resizing** to ignore the casing so that doors and windows can be moved or resized flush against an intersecting wall.
- **Inches Scrolled by Hotkeys** determines how far your plan will scroll when you press an arrow key. The initial default is 12 inches (300 mm).
- Check **Use Snap Grid/Units** to enable Grid Snaps, which snaps objects to a grid as you draw or edit them. See “Grid Snaps” on page 64.
- Specify the **Snap Unit**: the increments at which you want snapping to occur. The initial default is 1 inch (10 mm).

Preferences Dialog



The settings in the **Preferences** dialog are global: they apply to all plan files and are preserved between sessions. To access this dialog, select **Edit> Preferences**.

The **Preferences** dialog consists of panels which are accessed by clicking on the names in the Category tree along the left side.

The category tree structure is similar to other Windows programs. A “+” next to a category indicates that it has subcategories. Click the “+” to make the subcategories visible; to hide them, click the “-.”

The program remembers which panel you last accessed and opens to that panel the next time you open the dialog.

Preference dialog panels:

- Appearance Panel
- Colors Panel
- Library Browser Panel
- General Panel
- Folders Panel
- Edit Panel
- Render Panel
- Video Card Status Panel
- Reset Options Panel

Appearance Panel

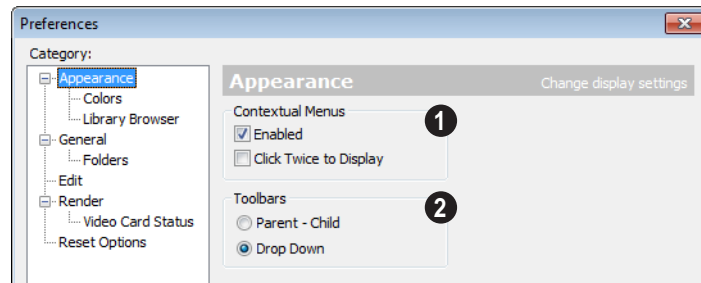

1 When **Contextual Menus** are enabled, you can right-click an object and a contextual menu displays with options that are unique to the selected object. The options in a contextual menu are usually the same as those on the Edit toolbar.

A menu of general commands displays if you right-click in an empty space in a view window, away from any object.

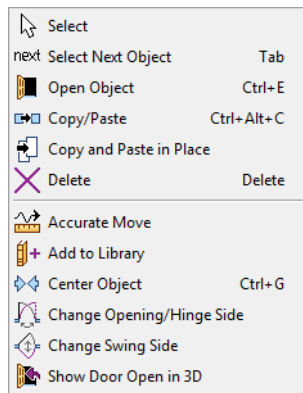

The contextual menu for a door

Since Home Designer Essentials can use the right-click as a general select, you have the

option to disable or limit the contextual menus.

- Check **Enabled** to activate contextual menus. Clear the check box to disable contextual menus.
- Check **Click Twice to Display** to require two right-clicks on an object before the contextual menu displays. This allows the first right-click to be a general select. See “Selecting Objects” on page 71.

In 3D views, the two clicks must be on the same object surface in order for the contextual menu to display: Clicking on two different surfaces of the same object is treated like two single-clicks.

- 2** Specify how **Toolbars** present child tools when a parent button is clicked.
- Choose **Parent-Child** to display child tools as buttons at the end of the toolbar where the parent button resides.
 - Choose **Drop Down** to display child tools when the drop-down arrow to the right of the parent button is clicked.

Colors Panel

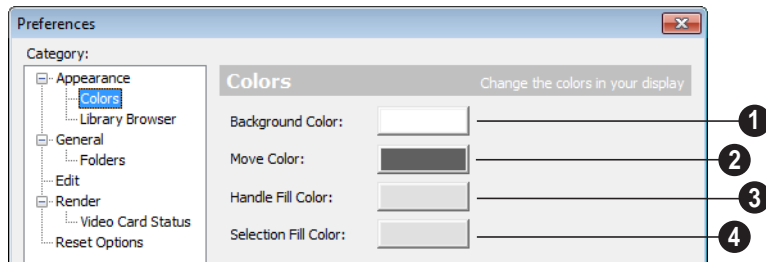

Click a color bar to open the **Color Chooser** dialog. See “Color Chooser Dialog” on page 309.

1 Background Color - Click the color bar to select the background color for floor plan view.

The background color for 3D views that do not use or a backdrop image is set in the **3D Backdrop** dialog. See “3D Backdrop Dialog” on page 319.

2 Move Color - Click the color bar to select the color of the lines that represent object(s) as they are being moved.

3 Handle Fill Color - Click the color bar to select the color for the edit handles for selected objects.

4 Selection Fill Color - Click the color bar to specify a color for selected objects. The color may change to ensure that selected objects are always visible, so this may not always be the color you expect.

 If the move color and the handle fill color are similar, it may be difficult to distinguish between active and inactive points. The colors should be sufficiently dissimilar to avoid confusion between active and inactive points.

Library Browser Panel

The Library Browser panel controls the appearance of the Library Browser window. See “The Library Browser” on page 283.

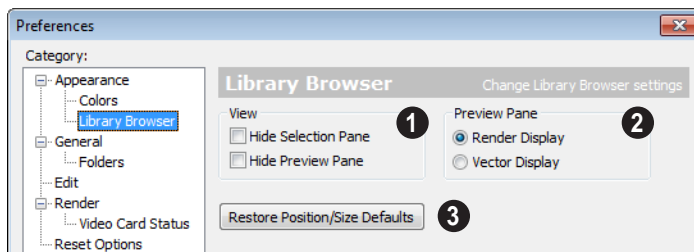

- 1 **View options** control the display of the main sections of the Library Browser.
- **Hide Selection Pane** - Check to hide the pane that displays objects in a selected library or library folder.
- **Hide Preview Pane** - Check to hide the pane that shows a preview of a selected object.
- 2 **Preview Pane** - Specify how selected library items look in the Preview Pane.
- **Render Display** - Library items previews display textures and appear as they do in 3D views.
- **Vector Display** - Library item previews are line-based and display patterns.
- 3 Click the **Restore Position/Size Defaults** button to restore the original position and size of the Library Browser: docked on the right side of the Home Designer Essentials window.

General Panel

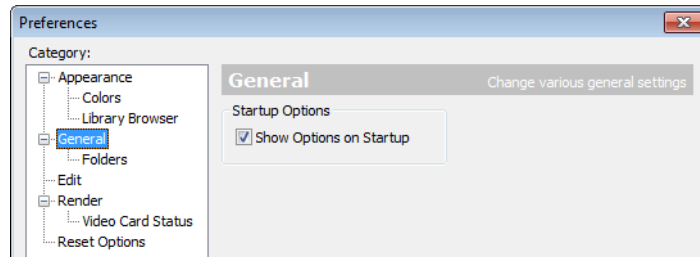

Check **Show Options at Startup** to open the **Startup Options** dialog when Home

Designer Essentials is launched. See “Startup Options” on page 17.

Folders Panel

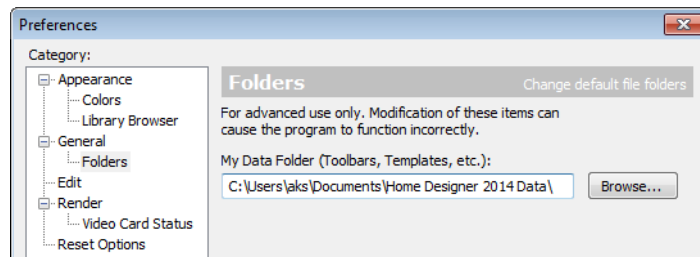

Important user-specific information is saved in a folder on your computer called **Home Designer Essentials 2014 Data**. This folder contains custom library content, toolbars,

template files, archive files, and other important data and is located in My Documents by default. See “Home Designer Essentials Data” on page 32.

While you cannot change the name of this directory, you can change its location. To avoid unexpected results, it is best to use a location on your local hard drive.

If you move this folder on your computer without specifying its location here, the program will automatically replace it using default information from the Home Designer

Essentials installation folder. The same result will occur if you specify a location on a network or removable device and this location becomes inaccessible. When this occurs, customized user settings will not be used and custom library content will not be available.

Edit Panel

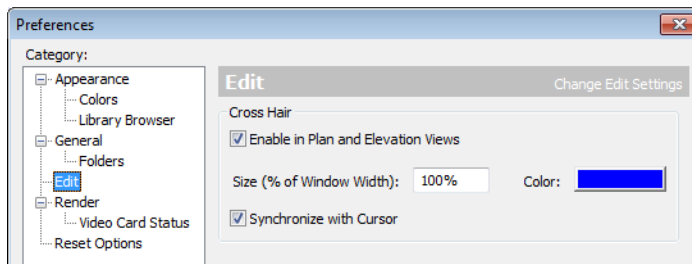

Use a cursor with **Cross Hairs** and control its appearance.

- Check **Enable in Plan and Elevation Views** to use a cross hair cursor in floor plan and elevation views. This option is checked by default.
- Click the **Color** bar to open the **Color Chooser** dialog and specify the color of the cross hairs.

- Cross hair size is specified as a percentage of the width of the view window. Specify the **Size (% of Window Width)** as 100% to extend the cross hairs across the entire screen.
- When **Synchronize with Cursor** is checked, the mouse pointer and cross hairs always move together on screen. If you feel that they do not keep up with your mouse movements, try unchecking this option.

Render Panel

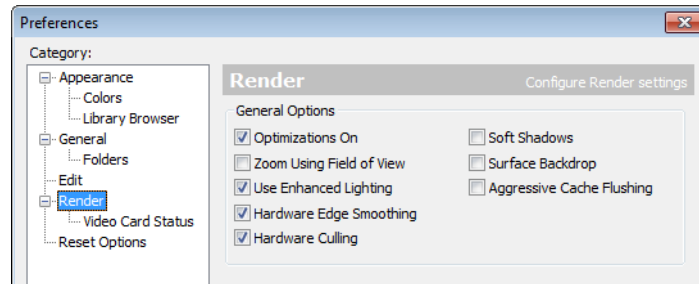

- **Optimizations On** saves rendering data to your video card, which speeds up rendering time. This option may cause problems if the rendering data for your model exceeds the video card's memory.

If your computer stops responding when rendering, try unchecking **Optimizations On**. This slows down rendering time considerably, though, so if the problem is not solved, leave this check box selected.

- **Zoom Using Field of View** directs the program to zoom in 3D views by adjusting the camera's Field of View, which can result in perspective distortion. See "Field of View" on page 330.

When **Zoom Using Field of View** is unchecked, zooming in 3D views is done by cropping or expanding the view's extents. See "Zooming" on page 329.

- When **Use Enhanced Lighting** is checked, Standard rendered views generate lighting effects that require a video card that supports OpenGL 2.0. Unchecking this box may speed up Standard rendering times somewhat; however, the quality of lighting effects will be reduced. Not available if your video card does not

support OpenGL 2.0. See "OpenGL and Hardware" on page 319.

- **Hardware Edge Smoothing** uses the video card to remove the jagged edges that sometimes result along surface edges, producing cleaner lines. Not available if your video card does not support this feature.
- **Hardware Culling** improves rendering times by preventing surfaces not actually visible in the scene from being generated. On some systems, this setting may slow down rendering times. If unchecking it does not solve the problem, though, leave this check box selected. See "System Requirements" on page 7 of the User's Guide.
- **Soft Shadows** displays shadows with soft edges instead of hard edges in **Final Views with Shadows** . See "Rendering Tips" on page 336.
- **Surface Backdrop** generates the backdrop image using hardware acceleration. For some graphics cards, this option improves rendering speed considerably.
- **Aggressive Cache Flushing** regularly flushes cached video memory, which may be helpful for older video cards. On most

systems, unchecking this box will produce faster rendering times.

Video Card Status Panel

The Video Card Status panel displays information about your video card, including the vendor and the version of OpenGL it uses. See “OpenGL and Hardware” on page 319.

This information may be important if you are having problems generating 3D views.

Notice the information following the **Acceleration** label. If your video card supports hardware acceleration for OpenGL,

this says “Installed Client Driver.” If it does not, it says “No Hardware Acceleration.” There is a significant difference in speed between rendering with acceleration and without.

The **Max Lights** value indicates how many lights you can have turned on at any given time when generating a 3D view. This value should be 8 or higher, depending on your video card. See “Lighting” on page 337.

Reset Options Panel

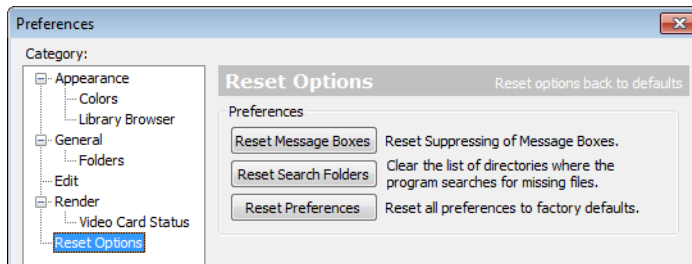

If message boxes have been suppressed, you can make them display again by clicking **Reset Message Boxes**.

Home Designer Essentials retains a list of locations where you have located missing files in the past. If you find that the program takes a long time to search for files before informing you that they are missing, you can

click the **Reset Search Folders** button to clear this list.

Click the **Reset Preferences** button to restore all preferences to those that originally came with the program. For the reset to take effect, you will need to restart the program.

Toolbars & Hotkeys

Two of the most efficient ways to access Home Designer Essentials's tools are the toolbars and keyboard shortcuts, also referred to as hotkeys.

Toolbars are organized into configurations, which are basically collections of multiple toolbars arranged for use during specific drawing tasks. Within a given toolbar configuration, buttons are arranged so that similar tools are located near one another.

Chapter Contents

- Toolbar Arrangement
- Hotkeys

Toolbar Arrangement

Toolbars can be viewed in Drop-Down or Parent-Child arrangement. You can specify which to use in the **Preferences** dialog. See “Appearance Panel” on page 50.

Drop-Down toolbar buttons have an arrow to the right of the button that accesses additional, related tools.

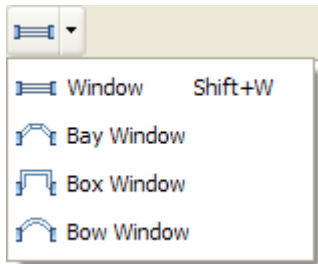

Alternatively, you can use the Parent-Child toolbar arrangement. In this arrangement,

you select a “parent” button to display its “child” buttons to the right.



Moving Toolbars

You can, if you wish, move any toolbar to a different location. Toolbars can be docked to any side of the program window, or they can be undocked and left floating. Undocked toolbars can also be moved outside of the program window.

The location of moved toolbars is not saved between program sessions. The next time you use Home Designer Essentials, the toolbars will be back in their original locations.

Hotkeys

Many Home Designer Essentials tools have a keyboard shortcut, or hotkey, associated with them. If such a hotkey exists, it will display to the right of the tool’s name in the menu.

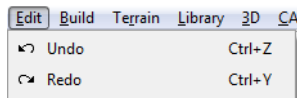

Edit menu items with button icons to the left and hotkeys to the right

To use a hotkey, simply press the appropriate key or combination of keys on your keyboard instead of selecting the menu item or clicking the toolbar button. For example, press the Ctrl and Z keys at the same time to perform

an **Undo** .

Layers

Layers are used to organize and manage the display of all objects in all views. A layer can be thought of as a transparency sheet with objects placed on it for viewing. Nearly all views use multiple layers, like a stack of transparencies put together to show different types of objects.

You can customize how each layer displays in a particular view in the **Display Options** dialog.

Multiple layers are organized into Layer Sets, which allow you to control which objects display in different views.

Chapter Contents

- Displaying Objects
- Layer Sets
- Display Options Dialog

Displaying Objects

The display of objects in different views is controlled by layer sets and layers in the **Display Options** dialog. See “Display Options Dialog” on page 60.

Primary and Secondary Layers

Every object is placed on a layer which controls whether it displays in a given view. This layer is referred to as the object’s primary layer.

In addition, some objects have secondary layers which may alter the appearance of objects on the primary layer, but do not control whether the objects display or not.

For example, the primary layer for base cabinets is “Cabinets, Base”. In addition, base cabinets have a number of secondary layers that control the display of the countertop, face indicators, door opening indicators, module lines and labels.

Note: If an object’s primary layer is turned off, information on its secondary layers will not display - even if those layers are turned on.

All layers with a check in the “Disp.” column display when the current layer set is active. Objects that are not displayed cannot be seen

or selected. If you try to place or draw an object on a layer that is hidden, the program asks if you want to turn the layer on.

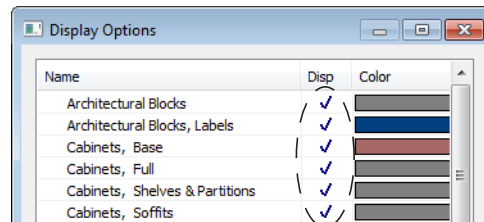

Some objects cannot stand alone in a drawing: they can only be inserted into another object. If the display of an object that contains an inserted object is turned off, the display of the inserted object will be turned off, as well. For example, if the display of a wall is turned off, any doors and windows in that wall will not display either. See “Inserted Objects” on page 294.

The **Color** attribute assigned to a layer determines how the lines representing objects on that layer appear in floor plan and Elevation views.

Many objects, including terrain and text objects, allow you to override the line color without changing the layer’s color attribute.

Layer Sets

Layer Sets are used to control the layer settings for different views in a plan file.

A layer set consists of a complete list of the layers in the current plan along with the

display settings for each layer as set for a particular type of view. These display settings can be modified, and can be different for each type of view. See “Display Options Dialog” on page 60.

Layer sets are file specific, which means that changes made in one plan file have no effect on the settings in other files.

Home Designer Essentials uses a different layer set for the each type of view of your plan:

- Floor plan view.
- Camera views and Overviews. See “3D View Tools” on page 320.
- Elevation views. See “Elevation Views” on page 322.
- Framing Overviews. See “Framing Overview” on page 322.
- Reference Display. See “The Reference Floor” on page 176.

- Print Model. See “Print Model” on page 388.

While any view is active, select **Tools>**

Display Settings> Display Options  to make changes to the layer set used for that view type.

Any changes made to settings in the **Display Options** dialog for one particular view will affect all views using that same layer set. For example, if you make changes for a camera view, all camera views and overviews in the current plan will be affected. See “Display Options Dialog” on page 60.

Unlike other layer sets, the Print Model layer set cannot be modified.

Display Options Dialog



The display of objects in all views is controlled in the **Display Options** dialog. To make changes to the display settings for a particular type of view, open a view of that type and select **Tools> Display Settings> Display Options**.

If the display of a particular layer is turned off and an object assigned to that layer is placed in the plan, the program will

automatically ask you if the layer should be turned on so that the new object will be visible. After you make your choice, the object will be created - even if you select “No.”

Only displayed objects are included when EMF files are exported, and only displayed objects print.

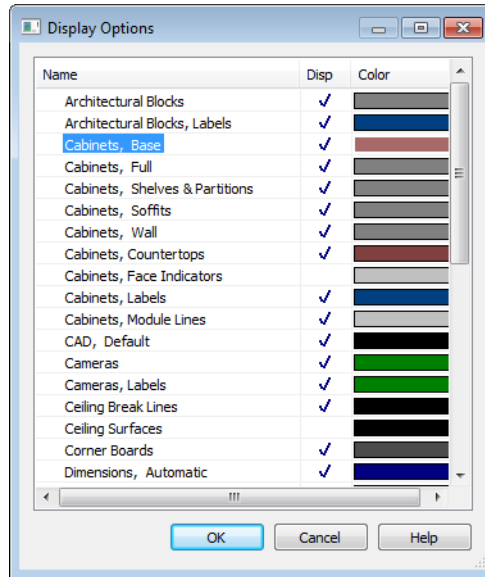

- Remove the check from the “Disp.” column to turn off the display of a category of objects in the current view.
- Click a color bar to open the **Color Chooser** dialog and set the display color for objects on that layer in floor plan and Elevation views. See “Color Chooser Dialog” on page 309.
- Click on a column header to sort all layers by that column. Click again to sort in reverse order.
- Click the size grip at the lower right corner and drag to resize the dialog box.

Note: Not all objects display in all views. For instance, door labels do not appear in 3D views.

Creating Objects

There are a wide variety of objects in Home Designer Essentials that you can use to create 3D models and plan drawings. Although these objects are sometimes very different from one another, the methods used to create them are similar.

Once an object is created, it can be selected and edited to meet the requirements of your project. The editing characteristics common to most objects are described elsewhere. See “Editing Objects” on page 70.

Chapter Contents

- Architectural vs CAD Objects
- Snap Behaviors
- Object Snaps
- Angle Snaps
- Grid Snaps
- Creating Objects
- Copying and Pasting Objects

Architectural vs CAD Objects

There are two broad categories of objects in Home Designer Essentials: architectural objects and CAD objects.

Text, text lines with arrows, and dimensions are 2D CAD objects that can be created and edited in floor plan view but do not display in 3D camera views and overviews. See “Dimensions” on page 342 and “Text” on page 354.

In contrast, architectural objects such as walls, cabinets, doors, windows, and stairs display in 2D and 3D views.

Some architectural objects, such as terrain features, have some behaviors in common with CAD objects and are referred to as CAD-based.

Snap Behaviors

There are three categories of snap behavior in Home Designer Essentials that affect how objects are created and how they can be edited:

- **Object Snaps**, which snap objects to other objects.
- **Angle Snaps**, which snap objects at specific angles.

- **Grid Snaps**, which snap objects to points on a grid.

You can select **Edit> Snap Settings** to quickly turn Object, Angle and Grid Snaps on or off.

To temporarily disable Snap Behaviors and other move restrictions, press the Ctrl key while dragging an edit handle. See “Moving Objects” on page 88.

Object Snaps

Object Snaps allow you to position objects precisely relative to each other; for example, to position lines so that their endpoints meet.

Object Snaps can be turned on or off by selecting **Edit> Snap Settings> Object Snaps**.

There are many locations on an object that other objects can snap to.

- Object endpoints and corners
- The midpoints of object edges

- Object center points
- Intersection points where an object drawn at an allowed angle meets another object.

In addition, **On Object** snapping occurs anywhere on an object’s edges and is most noticeable when Angle and Grid Snaps are turned off.

When multiple objects are selected, the selection set’s only snap point is its midpoint.

Extension Snaps

Extension snaps allow you to snap to a point that is not actually on an object. Instead, these snaps locate points that are either colinear to the end of a wall or orthogonal (at a 90° angle) to it.

Extension snaps function when you are drawing or editing walls and create a “sticky point” where the wall being drawn reaches a point that is either colinear or orthogonal to another wall’s end point. See “Drawing Walls” on page 103.

Angle Snaps

It is often important that objects be drawn at exact angles.

Angle Snaps allow you to draw walls, and other objects at angles in 7.5° increments.

Angle Snaps also affect the way objects rotate, the radius of arcs, and a variety of other operations.

Grid Snaps

Grid Snaps allow you to snap objects to points on a grid. This grid cannot be seen directly, but as you draw, move or resize an object, you can often see the snap points. The size of this Snap Grid can be controlled in the **Plan Defaults** dialog. See “General Plan Defaults Dialog” on page 48.

Grid Snaps and Angle Snaps

Of the three snap behaviors, Grid Snaps have the lowest priority and are overridden by Angle Snaps and Object Snaps.

When Grid snaps and Angle Snaps are both enabled, objects are drawn and edited using Polar Coordinates. For example, if the grid **Snap Unit** is set to 12" (1 foot), drawing a new wall at an Allowed Angle snaps the wall length to 0", 12", 24", and so on.

Creating Objects

In Home Designer Essentials, there are three ways to create objects: by clicking to place an object, by clicking and dragging to draw an object, or by importing custom pictures or metafiles.

If you create an object using any of these methods and the layer it will go on is turned

off, the program will ask you if you want to display the layer. See “Object Creation and Layers” on page 65.

While the size of the drawing area in Home Designer Essentials is limited only by the resources on your computer, it is best to begin your drawing near the origin, 0,0,0.

The current position of your mouse pointer displays in the Status Bar at the bottom of the program window. See “3D Drafting” on page 18.

Click-to-Create

Many objects, including doors and windows, cabinets, library symbols, terrain objects, text, pictures and images are created by clicking. Select a or library object, then click in the drawing area to place the object at that location.

Continue clicking to place the selected object until another tool is selected.

If you click at a location where there is not enough room for the object to be placed, one of two things may happen:

- Some objects, notably cabinets, doors, and windows, will resize smaller to fit into the space.
- Most objects cannot resize in this manner, so the program will present a warning message indicating that there is not sufficient space at the current location.

When most drawing tools are active or library symbols selected for placement, a preview outline follows your mouse pointer, indicating the size and shape of the object to be created. If your pointer is positioned at a location where the object cannot be placed, this preview outline will not display.

As you move the mouse pointer, the center point of the object’s back edge will snap to active snap points when **Grid Snaps** or **Object Snaps** are enabled. See “Snap Behaviors” on page 63.

Many architectural objects can be created in floor plan view or any 3D view. In order to

place a stand-alone, click-to-create object in 3D, it is necessary to click near a wall or within the Terrain Perimeter as these objects help orient the new object within the 3D space.

Clicking and Dragging

Other objects, including walls and railings, straight stairs, and terrain features are created by clicking and dragging to define either a path or an enclosed area. Select a tool, then click and drag in the drawing area to draw an object between your start and end points.

Continue drawing the selected object until another tool is selected.

You can temporarily slow the movement of the mouse as you drag by holding down the Shift key on your keyboard..

You can cancel any click-and-drag drawing operation before it is completed by pressing the Esc key on your keyboard, or by pressing any two mouse buttons at the same time.

Importing Objects

Pictures and metafiles can be imported into the program and placed in the drawing area with a click. See “Pictures, Images, & Walkthroughs” on page 370.

Object Creation and Layers

When it is created, every object is placed on a layer which controls whether and how it displays. See “Layers” on page 58.

If you try to create an object on a layer that is not set to display in the current view, the program will ask if you want to turn that layer on. See “Message Boxes” on page 23.

- Click **Yes** to create the object and turn on its layer in the current view.
- Click **No** to create the object but leave its layer turned off in the current view.
- Click **Cancel** to not create the object and leave the layer turned off.

Copying and Pasting Objects

New objects can also be created by cutting, copying, and pasting existing objects, either individually or in groups. Objects can be copied from one floor to another, one view window to another, and one file to another. Because copying uses the Windows Clipboard, some objects can be pasted into other applications, as well.

Objects cannot be pasted into any views that they cannot be created in normally. For example, text cannot be pasted into a 3D camera view or overview.

A few objects, such as Terrain Perimeters and camera symbols, cannot be copied.

Cut



Select **Edit> Cut** to remove the selected object(s) from the file and save them in the Windows Clipboard. To paste the selection in Home Designer Essentials or another application, select **Edit> Paste** or press **Ctrl + V** while in that application to enable the Paste function.

Copy



Select **Edit> Copy** to copy the selected object(s) to the Windows Clipboard. To paste the selection in Home Designer Essentials or another application, select **Edit> Paste** or press **Ctrl + V** while in that application to enable the Paste function.

Paste



Select **Edit> Paste** to enable Paste mode, then left- or right-click in the current view to paste the selected object(s) previously copied to the Windows Clipboard at that location.

Once pasted, these object(s) are selected. Objects pasted in 3D views are selected on their top surfaces.

If the selection being pasted consists of text, it is placed in a Text object.

Copy/Paste



Click the **Copy/Paste** edit button to copy the selected object(s) to the Windows Clipboard and immediately enable the **Paste**  function in Home Designer Essentials.

The **Copy/Paste**  edit button activates Paste mode in which each available edit tool and handle makes a copy in addition to its primary function and four new edit buttons display on the edit toolbar.



- Click the **Sticky Mode**  edit button remain in the current mode and place multiple copies of the selected object(s).

- Click the **Main Edit Mode**  edit button or press the Esc key to return to the selected objects's main edit toolbar.



If you paste a selection in a file other than its original source file, when you return to the original, Paste mode is still enabled.

The **Copy/Paste**  edit button can be used with the edit handles in either of two ways: by clicking or by dragging an edit handle.

To Copy/Paste by clicking

1. Select an object or objects to copy.
2. Click the **Copy/Paste**  edit button, select **Edit> Copy**  from the menu or press **Ctrl + C** to copy and then **Ctrl + V** to activate the Paste functionality. The cursor displays the Copy/Paste icon.
3. If you wish to paste the copy in a different view or program window, open that window.
4. If your cursor does not display the Copy/Paste icon, select **Edit> Paste** from the menu or press **Ctrl + V**.
5. Left- or right-click once to paste a copy of the object at that location.



To Copy/Paste by dragging

1. Select an object or objects to copy.
2. Click the **Copy/Paste**  edit button, select **Edit> Copy**  from the menu or press **Ctrl + C**. The cursor displays the Copy/Paste icon.
3. Drag an edit handle:
 - Drag the Move edit handle to position the copy at a new location.

4. You can position the copy accurately with respect to the original by watching the moved distance in the Status Bar at the bottom of the screen.

Sticky Mode

 Normally, after an action is performed using the edit tools or handles while in an edit mode such as Paste mode, you return to the Main Edit Mode. Click the **Sticky Mode** edit button to remain in Paste mode and continue pasting copies of the selected object(s).

To exit Paste mode and return to the main edit toolbar for the selected object, click the **Main Edit Mode**  edit button or press the Esc key on your keyboard. If you have not pasted a copy of the selected object and immediately click **Copy/Paste**  after returning to the Main Edit Mode, **Sticky Mode**  is still enabled.

Copy and Paste in Place

 Click the **Copy and Paste in Place** edit button to create a copy of the selected object(s) at the same location as the original. The copy remains selected so you can perform additional operations.



Because multiple walls, railing and fencing cannot share the same space, the **Copy and Paste in Place**  edit button is not available for these objects.

Paste Hold Position

 When copying between different floors or view windows, you can paste

a copy at the same absolute position as the original selection using **Paste Hold Position**.

To use Paste Hold Position

1. Select the object(s) to be copied.
2. Click the **Copy/Paste**  edit button.
3. Switch to the desired floor or plan file and select **Edit> Paste> Paste Hold Position** .
4. A copy is placed at the same X, Y coordinates on the new floor or in the new plan as the original's position.

Paste Special



The **Paste Special** tool allows you to choose a representation for the selection to be pasted.

Selections can be pasted as:

- Enhanced Windows Metafiles (EMF). See “Metafiles” on page 376.
- Device Independent Bitmaps (BMP). See “Importing Pictures” on page 375.
- Unformatted non-unicode text (TXT).

- File Name (a path to a file). Depending on the file type, it will be either opened or imported (if supported).
- Unformatted text (HTML). Pastes as text.
- Model Objects - Home Designer Essentials format, not compatible with other programs.

To use Paste Special

1. Select an object, image, text or file on your computer and copy it.
2. Switch to the desired Home Designer Essentials view window and select **Edit> Paste> Paste Special** .
3. In the **Paste Special** dialog, select the desired representation for the selection and click OK.
4. Click in the drawing area to place the copy at that location.

Copy Region as Picture



The **Copy Region as Picture** tool allows you to copy any portion of the screen and save it as a picture. See “Copy Region as Picture” on page 378.

Editing Objects

Just as the methods used to create different objects in Home Designer Essentials are similar, the options for moving, rotating, resizing, and otherwise editing them are also alike.

Edit handles allow objects to be resized, relocated, or rotated using the mouse. Edit toolbar buttons and the contextual menus access edit tools relevant to the selected object(s). Most objects have a specification dialog that allows you to edit it in ways that are specific to that type of object.

The editing characteristics common to most objects are described in this chapter. Unique, object-specific editing behaviors and the specification dialogs are covered in their respective chapters.

Chapter Contents

- Selecting Objects
- Editing Line Based Objects
- Editing Arc Based Objects
- Editing Open Polyline Based Objects
- Editing Closed-Polyline Based Objects
- Editing Box-Based Objects
- Editing Spline Based Objects
- Displaying Objects
- Moving Objects
- Aligning Objects
- Resizing Objects
- Reshaping Objects
- Rotating Objects
- Deleting Objects
- Undo and Redo

Selecting Objects

“Select” refers to selecting an object for editing. An object must be selected before it can be edited.

In order for an object to be selected, it must be visible in the current view. See “Layers” on page 58.

When an object is selected, it displays edit handles and a grey selection fill color. In 3D views, a selected object will also display lines representing the selected edge or surface. The size of the edit handles does not change as you zoom in or out. To prevent them from stacking on one another, some edit handles may not display as you zoom away from the selected object.

When an object is selected, its edit toolbar also displays, typically on the upper left side of the Home Designer Essentials program window. See “The Edit Toolbar” on page 21.

Information about the selected object or objects may also display in the Status Bar. See “The Status Bar” on page 23.

A selected object remains selected until another object is selected, a different tool is activated, the Esc key on the keyboard is pressed, or any two mouse buttons are pressed at the same time.



Select Objects



Any object created using Home Designer Essentials can be selected using the **Select Objects** tool. Select **Edit > Select Objects**, click the toolbar button or press the **Space** bar on your keyboard to activate this tool, then click on an object to select it.

You can also select objects or open context sensitive menus using the right mouse button when any tool is active.

Selecting Similar Objects

If a tool other than **Select Objects**  is active, you can only select objects of that type using the left mouse button. For example, if the **Straight Exterior Wall**  tool is active, you can only select walls using the left mouse button.

This can be useful for selecting an object when many objects of a different type occupy the same space in floor plan view.

Objects can be selected using the right mouse button, regardless of which tool is active.

Right-Clicking

Regardless of which tool is active, you can select an eligible object by right-clicking on it once. When you right-click to select an object a contextual menu also appears, displaying the object’s edit tools. See “Contextual Menus” on page 22.

If a drawing tool is active and you right-click to select an object, you can unselect it by left-clicking in an empty space in the drawing area. Although a drawing tool is active, it is not used. If you then left-click a second time, the active tool will be used.

Selected Edge

When you click on a polyline- or box-based object, the edge that you click nearest becomes the selected edge and displays an

edit handle larger than those on other edges. The handle on this edge may also display at the point where you clicked to select it.

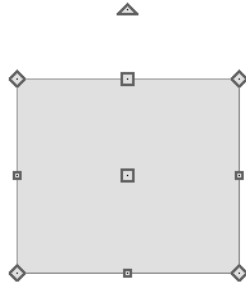

This edge can be edited on the Selected Line or Selected Arc tab of the object's specification dialog. See "Moving Objects Using Dimensions" on page 350, "Selected Line Tab" on page 222 and "Selected Arc Tab" on page 223.

Select Next Object

 If there is more than one object in a particular space, it may be difficult to select the desired object. When a nearby object is selected, click the **Select Next Object** edit button or press the Tab key until the desired object becomes selected. This function cannot be applied to groups of selected objects.

Marquee Select

Groups of objects can be selected by holding down either the Shift or Ctrl key when the **Select Objects**  tool is active and then dragging a marquee around the objects to be selected. An object does not need to be completely enclosed by the marquee to be selected: it will be selected if the marquee includes only a small portion of it.

If an object is currently selected and a selection marquee is drawn around it, that object becomes de-selected. If an object is currently selected and a marquee is drawn around other objects, the original object remains selected and the other objects are added to the selection set.

When using the marquee-select method, both text and architectural objects included in the marquee are selected. To remove an object from the selection set, hold down the Shift key and click it.

The Shift key can also be used to marquee-select objects of a similar type. For example, click the **Hinged Door**  child button, hold down the Shift key, drag a marquee, release the mouse button, and only door objects within the marquee are selected. The Ctrl key will always marquee-select objects of all types, regardless of the active tool.



To make marquee selection easier, you can turn off the display of objects you do not want to include in your selection set. See "Displaying Objects" on page 59.

Shift Select

You can select a group of objects by adding them to the selection set one by one. Select an object, hold down either the Shift or Ctrl key, and click additional objects to select them.

More than one type of object can be selected using this method, but the ability to edit the group-selected items is limited to attributes that all selected objects have in common.

To remove an object from a selection set, click it once more - again, with either the Shift or Ctrl key pressed.

Edit Area



The **Edit Area** tool allows you to quickly define an area of your plan and select the objects in that area. Once selected, they can then be repositioned, rotated, or deleted. Select **Edit> Edit Area**, then click and drag a rectangular marquee around the area that you would like to move.

Unlike other selection methods, the **Edit Area** tool cuts walls, railings and fencing where the selection marquee intersects them, allowing you to edit only the selected portion of these objects.

Some objects, such as cabinets, are included in the selection only if more than half of the object is contained within the marquee.

Editing Line Based Objects

Objects are considered line-based when they can be resized along one axis using the edit handles.

Straight walls and railings, straight stairs and straight roads are examples of line-based objects.

Most line-based objects can be connected to other like objects to form polyline-based objects. See “Editing Open Polyline Based Objects” on page 77 and “Editing Closed-Polyline Based Objects” on page 80.

Some objects, notably walls, have line-based editing behavior only when selected on certain surfaces. See “Editing Walls” on page 107.

Wall openings such as doors and windows have line-based editing behavior in floor plan view only but cannot be rotated, reversed or converted to an arc. See “Editing Doors” on page 142 and “Editing Windows” on page 160.

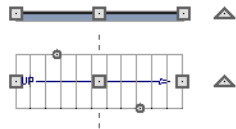

Other objects, such as stairs and roads, have additional edit handles that allow you to concentrically adjust the object’s width.

Using the Edit Handles

When selected, a typical line-based object displays four edit handles.

Any action performed using the edit handles can be cancelled by pressing the Esc key or any two mouse buttons at the same time.

Move

- Movement may be limited or stopped by other objects or Snap Behaviors. Move restrictions can be overridden by holding down the Ctrl key while dragging. See “Unrestricted Movement” on page 88.

Rotate

- The **Rotate** handle is used to rotate the object about its center. See “Rotating Objects” on page 92.

Extend/Change Angle

- Drag an end handle parallel to the selected line to change its length.
- Drag an end handle at an angle to the selected line to change its angle.

Adjust Width

Some line-based objects, such as stairs and roads, have additional handles that allow the width of the object to be adjusted.

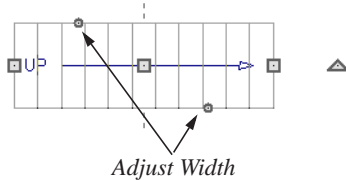

- Click and drag a small, round **Expand** handle to increase or decrease the object's width. By default, objects are resized in 1" increments. This Snap Unit is defined in the **Plan Defaults** dialog. See "General Plan Defaults Dialog" on page 48.

Using Dimensions

 Dimensions can be used to position line-based objects relative to other objects. See "Moving Objects Using Dimensions" on page 350.

Dimensions cannot, however, be used to adjust the length of line-based objects, or the width of line-based objects such as stairs.







Using the Specification Dialog

 Line-based objects can be edited using their specification dialogs. See "Specification Dialogs" on page 23.

Using the Edit Toolbar



A selected line-based object can be edited in a variety of ways using the buttons on the edit toolbar.

The following toolbar buttons may display on the edit toolbar for a selected line-based object:

- Click the **Select Next Object**  edit button to select nearby objects instead of the selected object. See "Selecting Objects" on page 71.
- Click the **Open Object**  edit button to open the specification dialog for the selected object(s). See "Specification Dialogs" on page 23.
- Click the **Copy/Paste**  edit button to copy the selected object(s) to the Windows Clipboard so they can be pasted elsewhere. See "Copying and Pasting Objects" on page 66.
- Click the **Copy and Paste in Place**  edit button to create a copy of the selected object(s) at the same location as the original. See "Copy and Paste in Place" on page 67.
- Click the **Delete**  edit button to delete the selected object(s). See "Deleting Objects" on page 93.
- Click the **Accurate Move**  edit button to slow down the mouse speed when using the edit handles. See "Accurate Move" on page 89.
- Click the **Center Object**  edit button to center an object along along a wall within a room or relative to a cabinet

fixture. See “Using Center Object” on page 90.

- Click the **Move to Front of Group**  edit button to display the selected object in front of other objects in the same drawing group. See “Move to Front of Group” on page 87.

- Click the **Break Line**  edit button to add a new corner or pivot point to the selected object. See “Break Line” on page 92.
- Click the **Change Line/Arc**  edit button to change a line-based object to an arc, or vice versa. See “Change Line/Arc” on page 92.

Editing Arc Based Objects

Objects are considered arc-based when they can be resized along a curve using the edit handles.

Curved walls and railings, curved stairs, and curved roads are examples of arc-based objects.

Most arc-based objects can be connected to other like objects to form polyline-based objects. See “Editing Open Polyline Based Objects” on page 77 and “Editing Closed-Polyline Based Objects” on page 80.

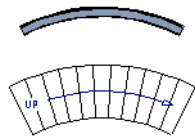

Some objects, notably curved walls, have arc-based editing behavior only when selected on certain surfaces. See “Editing Walls” on page 107.

Other objects, such as curved stairs and roads, have additional edit handles that allow you to concentrically adjust the object’s width.

Using the Edit Handles

When selected, a typical arc-based object displays seven edit handles.

Any action performed using the edit handles can be cancelled by pressing the Esc key or any two mouse buttons at the same time.

Move

- Two Move edit handles allow the arc to be relocated without changing its shape. One is located at the center of the chord and the other, at the arc center.
- Movement may be limited or stopped by other objects or Snap Behaviors. Move restrictions can be overridden by holding down the Ctrl key while dragging. See “Unrestricted Movement” on page 88.

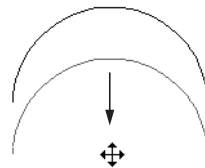

Move edit handle

Rotate

- The **Rotate** handle is used to rotate the arc about its center. See “Rotating Objects” on page 92.

Extend

- The end edit handles expand or contract the arc when moved along the arc radius or chord.
- If you follow the path of the arc, the end edit handles allow you to adjust the arc length.
- The angle formed by the center point of the arc and its two endpoints is referred to as the Included Angle. The Included Angle of the arc can be rotated at Allowed Angles. See “Angle Snaps” on page 64.

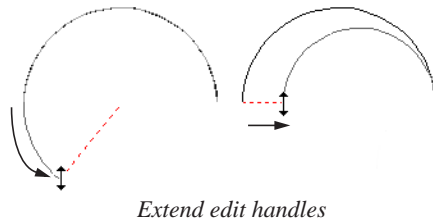

Resize

- Drag the small, round **Resize** edit handle to change the radius and included angle of the arc while maintaining its center.

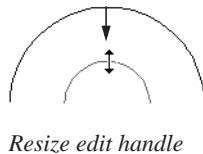

Reshape

- Drag the small triangular **Reshape** handle to change the length and location of the center without moving the endpoints.

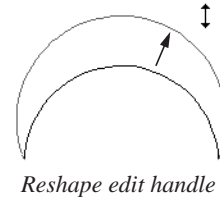

Adjust Width

Some arc-based objects, such as stairs, have additional handles that allow the width of the object to be adjusted.

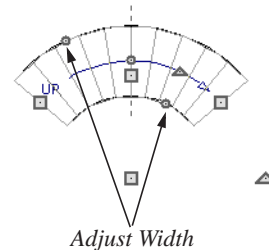

- Click and drag a small, round edit handle to increase or decrease the object’s width. By default, objects are resized according to the Snap Unit defined in the **Plan Defaults** dialog. See “General Plan Defaults Dialog” on page 48.

Using Dimensions



Dimensions can be used to position arc-based objects. Dimension lines typically locate tangent extension lines and any extension lines that may be parallel to those lines rather than the arc itself. See

“Moving Objects Using Dimensions” on page 350.

Using the Specification Dialog













Arc-based objects can be edited using their specification dialogs. See “Specification Dialogs” on page 23.

Using the Edit Toolbar

A selected arc-based object can be edited in a variety of ways using the buttons on the edit toolbar.

The following toolbar buttons may display on the edit toolbar for a selected arc-based object:

- Click the **Select Next Object**  edit button to select nearby objects instead of the selected object. See “Selecting Objects” on page 71.
- Click the **Open Object**  edit button to open the specification dialog for the selected object(s). See “Specification Dialogs” on page 23.
- Click the **Copy/Paste**  edit button to copy the selected object(s) to the Windows Clipboard so they can be pasted elsewhere. See “Copying and Pasting Objects” on page 66.
- Click the **Copy and Paste in Place**  edit button to create a copy of the selected object(s) at the same location as the original. See “Copy and Paste in Place” on page 67.
- Click the **Delete**  edit button to delete the selected object(s). See “Deleting Objects” on page 93.
- Click the **Accurate Move**  edit button to slow down the mouse speed when using the edit handles. See “Accurate Move” on page 89.
- Click the **Center Object**  edit button to center an object along a wall within a room or relative to a cabinet fixture. See “Using Center Object” on page 90.
- Click the **Move to Front of Group**  edit button to display the selected object in front of other objects in the same drawing group. See “Move to Front of Group” on page 87.
- Click the **Break Line**  edit button to add a new corner or pivot point to the selected object. See “Break Line” on page 92.
- Click the **Change Line/Arc**  edit button to change an arc-based object to a line, or vice versa. See “Change Line/Arc” on page 92.

Editing Open Polyline Based Objects

Open polyline-based objects are composed of individual line- and arc-based objects that

are connected at their end points but do not form an enclosed area.

Connected walls, stairs, and roads are examples of open polyline-based objects.

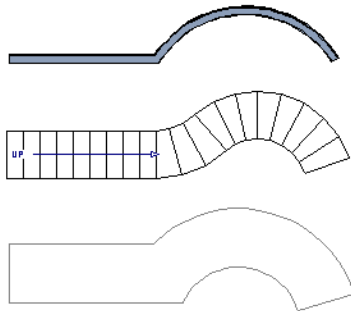

Other objects, such as connected stair and road segments, have additional edit handles that allow you to concentrically adjust the width of all segments of the object.

Using the Edit Handles

A polyline-based object can be composed of many segments.

When selected, an open polyline-based object displays a Move handle, a Rotate handle, a Reshape handle at the intersection of each segment, and an Extend handle at each end.

Each straight, line-based segment also has a Move edit handle along its length.

Each curved, arc-based segment has its own Move handle at the center of its chord, a Resize handle and, if it has an unlocked center, a Reshape handle. See “Editing Arc Based Objects” on page 75.

When a polyline is selected, the edge that you click nearest is called the selected edge, and certain operations affect only this edge. The Move handle of the selected edge is larger than that of other edges. It displays

along the length of a line segment, or at the center of the chord on an arc segment. See “Selected Edge” on page 71.

Any action performed using the edit handles can be cancelled by pressing the Esc key or any two mouse buttons at the same time.

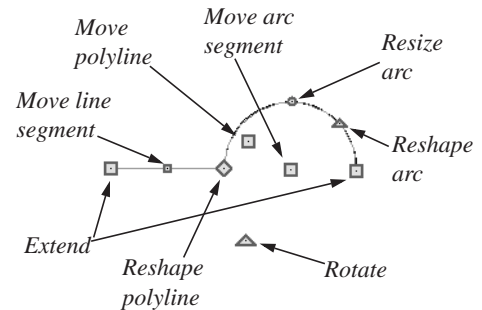

Move

- Click and drag the Move handle to move the object.
- Movement may be limited or stopped by other objects or Snap Behaviors. Move restrictions can be overridden by holding down the Ctrl key while dragging. See “Unrestricted Movement” on page 88.

Rotate

- The **Rotate** handle is used to rotate the object about its center. Its position varies depending on which edge is currently selected. See “Rotating Objects” on page 92.

Extend

- Click and drag an Extend handle to lengthen or shorten the unconnected end of the selected line or arc segment, or to change the radius of the selected arc. See “Editing Arc Based Objects” on page 75.

Reshape

- Click and drag a Reshape edit handle to change the angle and/or length of the segments on either side of it, or the size of the object.

Move Line Segment

- The **Move Line Segment** edit handle is found on straight segments of open polylines and moves the straight section perpendicular to itself. Adjacent segments may extend or contract in their original directions to maintain their connections.

Move Arc

- Click and drag the Move Arc edit handle to change the radius and/or chord length or position. Adjacent segments may extend, contract, or change angle to maintain their connections.

Resize Arc

- Click and drag the Resize Arc edit handle to change the radius, chord length and chord position of the arc segment. Adjacent segments may extend, contract, or change angle to maintain their connections.

Reshape Arc

- Click and drag the Reshape Arc edit handle to change the radius of the arc without moving its end points.

Adjust Width

Some arc-based objects, such as stairs and roads, have additional handles that allow the width of the object to be adjusted.

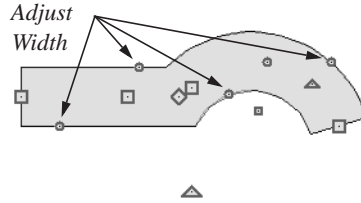

- Click and drag a small, round edit handle to increase or decrease the object's width. By default, objects are resized in 1" increments. This Snap Unit is defined in the **Plan Defaults** dialog. See "General Plan Defaults Dialog" on page 48.

Using Dimensions

 Dimensions can be used to move or reshape polyline-based objects. See "Moving Objects Using Dimensions" on page 350.

Using the Specification Dialog









 Open polyline-based objects can be edited using their specification dialogs. See "Specification Dialogs" on page 23.

Using the Edit Toolbar

A selected open polyline-based object can be edited in a variety of ways using the buttons on the edit toolbar.

The following toolbar buttons may display on the edit toolbar for a selected open polyline-based object:

- Click the **Select Next Object**  edit button to select nearby objects instead of the selected object. See "Selecting Objects" on page 71.

- Click the **Open Object**  edit button to open the specification dialog for the selected object(s). See “Specification Dialogs” on page 23.
- Click the **Copy/Paste**  edit button to copy the selected object(s) to the Windows Clipboard so they can be pasted elsewhere. See “Copying and Pasting Objects” on page 66.
- Click the **Copy and Paste in Place**  edit button to create a copy of the selected object(s) at the same location as the original. See “Copy and Paste in Place” on page 67.
- Click the **Delete**  edit button to delete the selected object(s). See “Deleting Objects” on page 93.
- Click the **Accurate Move**  edit button to slow down the mouse speed when using the edit handles. See “Accurate Move” on page 89.
- Click the **Center Object**  edit button to center an object along a wall within a room or relative to a cabinet fixture. See “Using Center Object” on page 90.
- Click the **Move to Front of Group**  edit button to display the selected object in front of other objects in the same drawing group. See “Move to Front of Group” on page 87.
- Click the **Break Line**  edit button to add a new corner or pivot point to the selected object. See “Break Line” on page 92.
- Click the **Change Line/Arc**  edit button to change a line-based polyline edge to an arc, or vice versa. See “Change Line/Arc” on page 92.

Editing Closed-Polyline Based Objects

Closed polyline-based objects are composed of individual line- and arc-based objects joined end-to-end and forming an enclosed area.

Terrain features and stair landings are examples of closed polyline-based objects.

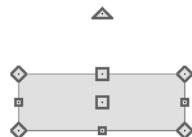

Using the Edit Handles

A polyline can be composed of many segments.

When selected, a closed polyline-based object displays a Move handle, a Rotate handle, and a Reshape handle at the intersection of each segment.

Each straight, line-based segment has a Move edit handle along its length.

Each curved, arc-based segment has its own Move handle at the center of its chord, a Resize handle and a Reshape handle. See “Editing Arc Based Objects” on page 75.

When a polyline is selected, the edge that you click nearest is called the selected edge, and certain operations affect only this edge. The Move handle of the selected edge is larger than that of other edges. It displays along the length of a line segment, or at the center of the chord on an arc segment. See “Selected Edge” on page 71.

Any action performed using the edit handles can be cancelled by pressing the Esc key or any two mouse buttons at the same time.

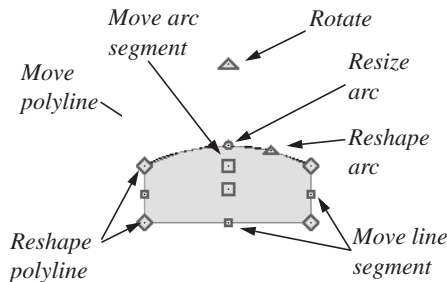

Move

- Click and drag the Move handle to move the object.
- Movement may be limited or stopped by other objects or Snap Behaviors. Move restrictions can be overridden by holding down the Ctrl key while dragging. See “Unrestricted Movement” on page 88.

Rotate

- The **Rotate** handle is used to rotate the object about its center. Its position varies depending on which edge is currently selected. See “Rotating Objects” on page 92.

Reshape

- Click and drag a Reshape edit handle to change the angle and/or length of the segments on either side of it, or the size of the object.

Move Line Segment

- The **Move Line Segment** edit handle is found on straight segments of closed polylines and moves the straight section-perpendicular to itself. Adjacent segments may extend or contract in their original directions to maintain their connections.

Move Arc

- Click and drag the Move Arc edit handle to change the radius and/or chord length or position. Adjacent segments may extend, contract, or change angle to maintain their connections.

Resize Arc

- Click and drag the Resize Arc edit handle to change the radius, chord length and chord position of the arc segment. Adjacent segments may extend, contract, or change angle to maintain their connections.

Reshape Arc

- Click and drag the Reshape Arc edit handle to change the radius of the arc without moving its end points.

Using Dimensions



Dimensions can be used to move or reshape closed polyline-based objects. See “Moving Objects Using Dimensions” on page 350.

Using the Specification Dialog













Closed polyline-based objects can be edited using their specification dialogs. See “Specification Dialogs” on page 23.

Using the Edit Toolbar

A selected closed polyline-based object can be edited in a variety of ways using the buttons on the edit toolbar.

The following toolbar buttons may display on the edit toolbar for a selected closed polyline-based object:

- Click the **Select Next Object**  edit button to select nearby objects instead of the selected object. See “Selecting Objects” on page 71.
- Click the **Open Object**  edit button to open the specification dialog for the selected object(s). See “Specification Dialogs” on page 23.
- Click the **Copy/Paste**  edit button to copy the selected object(s) to the Windows Clipboard so they can be pasted elsewhere. See “Copying and Pasting Objects” on page 66.
- Click the **Copy and Paste in Place**  edit button to create a copy of the selected object(s) at the same location as the original. See “Copy and Paste in Place” on page 67.
- Click the **Delete**  edit button to delete the selected object(s). See “Deleting Objects” on page 93.
- Click the **Accurate Move**  edit button to slow down the mouse speed when using the edit handles. See “Accurate Move” on page 89.
- Click the **Center Object**  edit button to center an object along a wall within a room or relative to a cabinet fixture. See “Using Center Object” on page 90.
- Click the **Move to Front of Group**  edit button to display the selected object in front of other objects in the same drawing group. See “Move to Front of Group” on page 87.
- Click the **Break Line**  edit button to add a new corner or pivot point to the selected object. See “Break Line” on page 92.
- Click the **Change Line/Arc**  edit button to change a line-based polyline edge to an arc, or vice versa. See “Change Line/Arc” on page 92.

Editing Box-Based Objects

Box-based objects are similar to closed polyline-based objects, but must always have four sides with right-angled corners.

Text objects, many library symbols, pictures and images are examples of box-based objects.

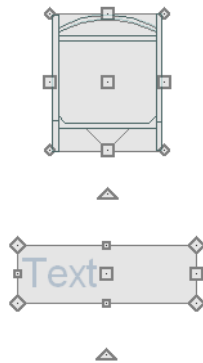

Using the Edit Handles

When selected, a box-based object displays ten edit handles.

Any action performed using the edit handles can be cancelled by pressing the Esc key or any two mouse buttons at the same time.

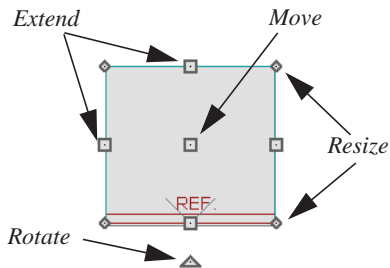

- Click and drag the Move handle to move the object.
- Movement may be limited or stopped by other objects or Snap Behaviors. Move restrictions can be overridden by holding

down the Ctrl key while dragging. See “Unrestricted Movement” on page 88.

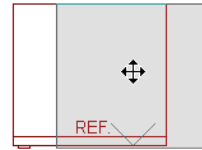

- The four **Resize** handles located at each corner are used to increase or decrease the size of the object.

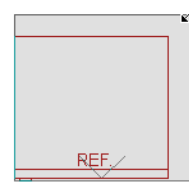

- The four **Extend** handles display along each edge. If you select an object on an edge, the Extend handle displays at the point where you clicked; otherwise, it displays at the center of the edge.

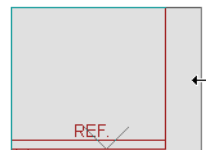

- The triangular **Rotate** handle located near the selected edge of the object is used to rotate it about its center. The pointer changes to a circular arrow  when moved over this handle. See “Rotating Objects” on page 92.

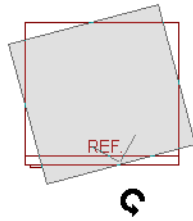

Using Dimensions

 Dimensions can be used to move or reshape box-based objects. See “Moving Objects Using Dimensions” on page 350.









Using the Specification Dialog

 Box-based objects can be edited using their specification dialogs. See “Specification Dialogs” on page 23.

Using the Edit Toolbar

A selected closed polyline-based object can be edited in a variety of ways using the buttons on the edit toolbar.

The following toolbar buttons may display on the edit toolbar for a selected closed polyline-based object:

- Click the **Select Next Object**  edit button to select nearby objects instead of the selected object. See “Selecting Objects” on page 71.
- Click the **Open Object**  edit button to open the specification dialog for the selected object(s). See “Specification Dialogs” on page 23.
- Click the **Copy/Paste**  edit button to copy the selected object(s) to the Windows Clipboard so they can be pasted elsewhere. See “Copying and Pasting Objects” on page 66.
- Click the **Copy and Paste in Place**  edit button to create a copy of the selected object(s) at the same location as the original. See “Copy and Paste in Place” on page 67.
- Click the **Delete**  edit button to delete the selected object(s). See “Deleting Objects” on page 93.
- Click the **Accurate Move**  edit button to slow down the mouse speed when using the edit handles. See “Accurate Move” on page 89.
- Click the **Center Object**  edit button to center an object along a wall within a room or relative to a cabinet fixture. See “Using Center Object” on page 90.
- Click the **Move to Front of Group**  edit button to display the selected object in front of other objects in the same drawing group. See “Move to Front of Group” on page 87.

Editing Spline Based Objects

Objects are considered spline-based when they can be edited similar to CAD splines

using their edit handles.

A Spline is a curve that passes smoothly through a set of points. Splines are typically used in situations where there is an irregular curve. Splines are useful wherever a free-flowing curve is needed.

Round and kidney-shaped terrain features are spline-based objects. See “Terrain” on page 258.



Using the Edit Handles

When a spline is selected, several different types of handles display.

Any action performed using the edit handles can be cancelled by pressing the Esc key or any two mouse buttons at the same time.

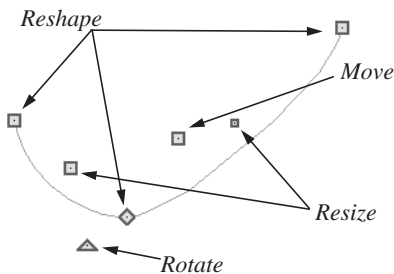

Move

- Click and drag the Move handle to move the object.
- Movement may be limited or stopped by other objects or Snap Behaviors. Move restrictions can be overridden by holding

down the Ctrl key while dragging. See “Unrestricted Movement” on page 88.

Rotate

- Click and drag the Rotate edit handle to rotate the entire spline.

Reshape

- The Reshape edit handles display along the spline at each vertex. Click and drag a Reshape edit handle to change the length, angle and curve of adjacent segments without affecting other reshape handles.

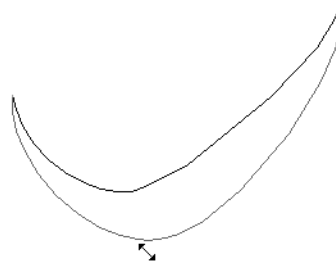

Resize

- The Resize edit handles display along the spline, between each vertex. Click and drag a Resize edit handle to move the adjacent vertices and lengthen or shorten adjacent segments.

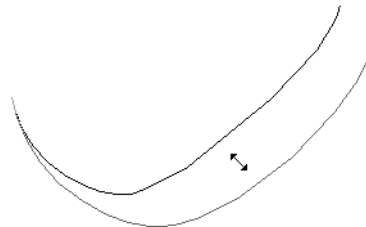











Using the Specification Dialog

 Spline-based objects can be edited using their specification dialogs. See “Specification Dialogs” on page 23.

Using the Edit Toolbar

A selected spline-based object can be edited in a variety of ways using the buttons on the edit toolbar.

The following toolbar buttons may display on the edit toolbar for a selected spline-based object:

- Click the **Select Next Object**  edit button to select nearby objects instead of the selected object. See “Selecting Objects” on page 71.
- Click the **Open Object**  edit button to open the specification dialog for the selected object(s). See “Specification Dialogs” on page 23.
- Click the **Copy/Paste**  edit button to copy the selected object(s) to the Windows Clipboard so they can be pasted elsewhere. See “Copying and Pasting Objects” on page 66.
- Click the **Copy and Paste in Place**  edit button to create a copy of the selected object(s) at the same location as the original. See “Copy and Paste in Place” on page 67.
- Click the **Delete**  edit button to delete the selected object(s). See “Deleting Objects” on page 93.
- Click the **Accurate Move**  edit button to slow down the mouse speed when using the edit handles. See “Accurate Move” on page 89.
- Click the **Center Object**  edit button to center an object along a wall within a room or relative to a cabinet fixture. See “Using Center Object” on page 90.
- Click the **Move to Front of Group**  edit button to display the selected object in front of other objects in the same drawing group. See “Move to Front of Group” on page 87.
- Click the **Break Line**  edit button to add a new corner or pivot point to the selected object. See “Break Line” on page 92.
- Click the **Move to Front of Group**  edit button to display the selected object in front of other objects in the same drawing group. See “Move to Front of Group” on page 87.

Displaying Objects

The display of objects in 2D and 3D views can be controlled by layer. See “Displaying Objects” on page 59.

Line and Fill Styles

Line style and color can be controlled by layer or overridden in the specification

dialogs for many objects. See “Line Style Tab” on page 225.

In addition, some objects have a fill style that can be specified in the objects’ specification dialogs. See “Fill Style Tab” on page 225.

Color On/Off



The display of color on-screen can be toggled on and off in 3D by selecting **Tools> Display Settings> Color On/Off**.

The display of colors may or may not make a view easier to understand. Experiment to see what works for you.

You can also print in color or gray scale. See “Print Dialog” on page 387.

Drawing Groups

Each object in a plan file belongs to one of three drawing groups, which influences whether it displays in front of or behind other objects.

- The **Default Group** is where most objects are placed when first created.
- Objects on the **Back Group** display behind those in the other two drawing groups.
- Objects on the **Front Group** display in front of those in the other two drawing groups.

Most objects are drawn in the Default Group. Notable exceptions are imported pictures, which are placed in the Back Group. Objects in the Default Group display in front or behind one another according to program-defined rules that can be modified in only limited ways.

Move to Front of Group



Click the **Move to Front of Group** edit button to move the selected object(s) so that it displays in front of other objects in the same drawing group.

Move to Front of Group  only affects the display of objects when they are of the same type: for example, furnishings, base cabinets, or wall cabinets. It cannot make a base cabinet display in front of a wall cabinet; but it can make a selected wall cabinet display in front of other wall cabinets.

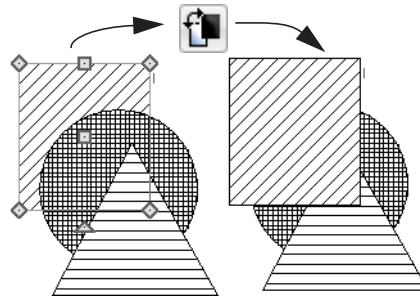

Textures

The appearance of architectural objects in 3D views is affected by the materials applied to the objects’ surfaces. See “Materials” on page 300.

In **3D** views, you can turn on or off the display of textures by selecting **3D> Toggle**

Textures .

Delete Surface



In any 3D view, select **3D> Delete Surface**, then click a surface in the view to temporarily remove the surface from

the current view. See “Delete 3D Surface” on page 324.

Refresh Display

Refresh Display redraws the current window to clean up extra lines, show missing

items, and correct random on-screen effects caused by changes to a model. Select **Tools> Display Settings> Refresh Display** or press the F5 key to refresh the on-screen display.

Moving Objects

Objects can be moved using the edit handles as well as a variety of edit tools. Multiple selected objects can also be moved as a group. See “Selecting Objects” on page 71.

Using the Edit Handles

Select an object, then click the **Move** edit handle and drag it to a new location. When your pointer is over the Move handle, it displays a four-headed arrow.

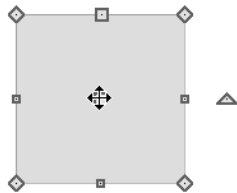

When moved, the selected object moves orthogonal, or at a right angle to, any of its edges.

As an object is moved, it jumps at set increments when **Grid Snaps** are enabled. See “Grid Snaps” on page 64.

If an selected object passes over its original location as it is being moved, it will snap to that location.

You can temporarily slow the movement of your mouse as you drag an edit handle by

holding down the Shift key on your keyboard.

Bumping/Pushing

When an object bumps into another similar object while it is being moved, it stops. Continue dragging and the selected item resumes movement through the obstructing object.

Walls, wall openings, cabinets, furnishings and fixtures are examples of objects that can push other objects of these same types once they have bumped into them. Instead of dragging through the obstructing object(s), release the mouse button and then click and drag the Move edit handle a second time in the same direction to push.

Unrestricted Movement

Many objects have restrictions placed on their movement by their own properties or specification settings. Architectural objects, for example, bump into other 3D objects as they are being moved.

Other move restrictions are activated by the **Snap Settings**. See “Snap Behaviors” on page 63.

These restrictions can be overridden when necessary by holding down the Ctrl key while dragging to move an object.

To move an object freely

1. Select the object.
2. Hold down the Ctrl key.
3. Click the Move edit handle and drag it to the new location.

You can also press the Ctrl key while dragging an object's Move handle to override move restrictions.

Accurate Move



Click the **Accurate Move** edit button, then move the selected object(s) at a slower speed than normal for greater precision. **Accurate Move** can also be used to resize, reshape or rotate objects.

Accurate Move  is not a toggle button: it only affects the speed of the mouse during the next edit. The next time you want to use this edit tool, you need to click it again.

You can also slow down the movement speed of a selection after you have started moving it by pressing the Shift key. Release the Shift key to resume movement at normal speed.

Center Object



The **Center Object** edit button allows you to move walls, cabinets and other objects so that they are centered along a wall within a room or relative to a window or cabinet.

Using Dimensions



Objects or the selected edges of some objects can be moved using dimensions. See “Moving Objects Using Dimensions” on page 350.

Aligning Objects

It is often important to align objects such as text boxes or walls, or to align objects on different floors. There are several methods to choose from.

Using the Mouse Cross Hairs

Objects can be aligned by eye using the mouse cross hairs as a reference. This method can help you draw, place and edit objects quickly and with reasonable accuracy, but is not necessarily as accurate as some of the other approaches described here.

The mouse cross hairs can be turned on and off by selecting **Tools> Display Settings> Show Crosshairs**.

Using Snap Settings

With **Object Snaps**, you can snap the edge of a selected object to that of another. Select an edge of an object. Drag it to the edge of another object, then release the mouse.

With **Grid Snaps** on, objects snap at increments equal to the **Snap unit** specified in the **Plan Defaults** dialog rather than onto the grid itself. This does not align objects to

the grid unless they were already snapped to the grid. See “Snap Behaviors” on page 63.

Using Dimensions



Create a temporary or manual dimension relative to an object such as a wall or line, and relocate the objects to the same dimension. See “Moving Objects Using Dimensions” on page 350.



Text objects can be aligned using settings in the Text Specification dialog. See “Aligning Text” on page 361.

Using Center Object



The **Center Object** edit button can be used to center a variety of objects relative to another object.

To center an object

1. Select an object.
2. Click the **Center Object**  edit button.
3. Move the mouse pointer over the object you would like to center the selected object relative to.
 - As the pointer passes over an eligible object, it becomes highlighted and a dashed centering axis line displays.
4. When the desired centering axis displays, click once to center the selected object along that axis line.

To center an object in a room

1. Select an object such as a cabinet.
2. Click the **Center Object**  edit button.
3. Move the mouse pointer in the room that you would like to center the selected object relative to.
 - As you move the pointer, a centering axis will display along the wall it is closest to.
 - The selected object does not have to be inside a room in order to be centered relative to that room.
4. When a centering axis displays along the correct wall, click once.
5. The object is moved perpendicular to the centering axis.

If you click outside an exterior wall instead of clicking inside, the selected object is centered along the edge of the Exterior Room. See “The Exterior Room” on page 122.

Aligning Objects on Different Floors

Objects on different floors can be aligned with one another using the **Reference**

Display . See “The Reference Floor” on page 176.

Resizing Objects

Objects can be resized using the edit handles and specification dialogs.

Using the Edit Handles

The end, corner and/or side edit handles can be used to resize a selected object.

To override any movement restrictions caused by snap settings or the presence of other objects, press the Ctrl key while dragging an edit handle.

As an object is resized, any dimensions indicating its size will update to reflect your changes. You can use dimensions as references to help you achieve the correct size for most objects.

You can temporarily slow the movement of your mouse as you drag an edit handle by holding down the Shift key on your keyboard.

Using the Specification Dialog



Most objects can be accurately resized in their specification dialogs. See “Specification Dialogs” on page 23.

Using Dimensions



Many objects can be resized by selecting an edge and then moving that edge using dimensions. See “Moving Objects Using Dimensions” on page 350.

Walls can also be resized using dimensions; however, it is important to understand that the selected edges of other objects cannot be resized using dimensions - they can only be moved. To resize an edge, select an adjacent edge and move that edge instead.

Reshaping Objects

There is a variety of ways to reshape objects using the edit handles, specification dialogs and edit toolbar buttons.

Some objects, notably box-based objects, cannot be reshaped - only resized. See “Resizing Objects” on page 90.

Using the Edit Handles

Depending on the type of object selected, the end, corner and/or side edit handles can be used to reshape a selected object.

To override any movement restrictions caused by snap settings or the presence of other objects, press the Ctrl key while dragging an edit handle.

You can temporarily slow the movement of your mouse as you drag an edit handle by

holding down the Shift key on your keyboard.

Using the Specification Dialog



A variety of terrain objects can be reshaped by editing values on either the Selected Line or Selected Arc tab of their specification dialogs. See “Selected Line Tab” on page 222 and “Selected Arc Tab” on page 223.

Using Dimensions



Both temporary and manually drawn dimensions can be used to increase or decrease the distance between the edge a

line- or polyline-based object and another, parallel edge or line.

Break Line

 The **Break Line** edit button can be used to break an individual line-, arc-, or spline-based object into two segments. The edges of a polyline-based object can also be broken.

Note: The Break Line edit button is not available for box-based objects or some architectural objects such as stairs.

The **Break Line**  edit tool can be used to create two types of breaks: partial breaks and complete breaks.

When a partial break is created, a new corner edit handle is placed at the location of the break. Partial breaks are also referred to as joints, nodes or pivot points.

- Click the **Break Line**  edit button to add a new corner or pivot point to the selected object.

To create a partial break

1. Click the object or edge that you want to break into two segments.

2. Click the **Break Line**  edit button once or press the 3 key.
3. Click the edge to create a new corner edit handle at that location and two separate edges on either side of that handle.

If you click and drag one of the edit handles on either side of the partial break, the edge moves at a right angle to itself and another edge forms, connecting the moved edge with the one on the other side that does not move.

You can remove an edge from a polyline-based object by clicking and dragging a corner handle until it snaps to an adjacent corner handle.

Change Line/Arc

 Select an individual line-based or arc-based object or a segment of a polyline-based object and click the **Change Line/Arc** edit button to convert the selected segment from a line to an arc or vice versa.

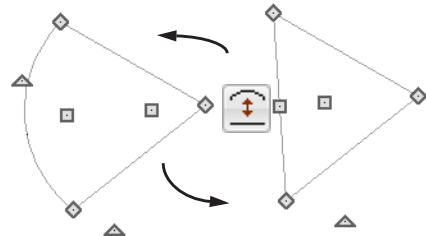

Rotating Objects

Objects can be rotated using the edit handles as well as a variety of edit tools. Multiple selected objects can also be rotated as a group. See “Selecting Objects” on page 71.

By default, an object or group of objects rotate about the center point of the selection set.

Using the Edit Handles

Select an object, then click the triangular **Rotate** edit handle and drag it in any direction. When your pointer is over the Rotate handle, it displays a curved arrow.

The angles of line-based objects can also be changed by dragging an end handle in a direction other than parallel to the object. The object rotates about the opposite end point. See “Editing Line Based Objects” on page 73.

Objects snap to Allowed Angles as they are rotated. See “Angle Snaps” on page 64.

To override any movement restrictions caused by snap settings or the presence of other objects, press the Ctrl key while dragging an edit handle.

You can temporarily slow the movement of your mouse as you drag an edit handle by

holding down the Shift key on your keyboard.

Using the Specification Dialog



The exact angle of some objects such as lines, arcs, walls and the selected edges of polylines can be specified on either the General tab, Selected Line tab, or Selected Arc tab of that object’s specification dialog. See “Selected Line Tab” on page 222 and “Selected Arc Tab” on page 223.

Reverse Plan





The **Reverse Plan** tool is a quick way to mirror a plan so that everything on all floors of the entire plan is swapped left to right rather than rotated.

Select **Tools> Reverse Plan**  to reflect an entire plan right to left, as though it were reflected about a vertical line.

Deleting Objects

Objects can be deleted in a variety of ways:

- Select an object or group of objects, then click the **Delete**  edit button, select **Edit> Delete**  from the menu, or press the either the Delete or Backspace key on your keyboard.
- Entire categories of objects can be deleted using the **Delete Objects** dialog.
- Objects are deleted if the floor they are placed on is deleted. See “Deleting Floors” on page 174.

If an object has a line with arrow attached to it, the arrow is deleted if the object is deleted. To prevent the arrow from being deleted, drag the attached end away from the object before deleting it.

Delete Objects Dialog



Use the **Delete Objects** dialog to delete all objects of one or more specified types in one room, on the current floor, or in the entire plan.

To use the Delete Objects dialog

1. Select **Edit> Delete Objects**  to open the **Delete Objects** dialog.

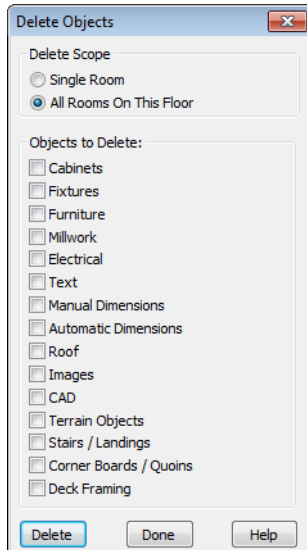

2. Specify the **Delete Scope** as **Single Room** or **All Rooms On This Floor**.
3. In the **Delete** section, check the box for each category of objects you want to delete. Click **Select All** to check all the boxes or **Clear All** to uncheck all boxes.
4. When the scope is set to **Single Room**:

- Move your cursor into the drawing area and click in a room of the plan to delete objects of the selected type within that room without closing the dialog.
 - Continue clicking on rooms or choose a different Delete Scope.
 - Click **Done** when all selections have been deleted.
5. If you select **All Rooms On This Floor**, you do not need to click in floor plan view. The **Delete** button becomes available, and clicking it closes the dialog and deletes the specified objects.

Deleting Polyline Edges

To remove an edge from a polyline, drag a corner handle until it overlaps an adjacent corner handle to remove the edge between them and merge them into a single handle. See “Reshaping Objects” on page 91.

Delete Surface

 In any 3D view, select **3D> Delete Surface**, then click a surface in the view to temporarily remove the surface from the current view without permanently affecting the object. See “Delete 3D Surface” on page 324.



Undo and Redo



The **Undo** and **Redo** commands allow you to both undo the last action performed, as well as redo actions that were recently Undone.



The ten most recent actions can be Undone or Redone. Actions that can be Undone and

Redone include creating, editing, and deleting objects.

To Undo an action, select **Edit> Undo** , click the **Undo**  button, or press **Ctrl + Z** on your keyboard.

The Redo command is only available immediately after Undo has been used. To Redo an Undone action, select **Edit>**

Redo , click the **Redo**  button or press Ctrl + Y on your keyboard.

It is important to note that **Undo**  and **Redo**  do not affect all actions in the program, including:

- Save and Save As. See “Saving, Exporting, and Backing Up Files” on page 33.
- Changes made in the Library Browser. See “The Library Browser” on page 283.
- Changes made in a dialog while the dialog box is open. See “Dialogs” on page 22.
- Changes made to the display by panning the display or zooming in or out. See “Undo Zoom” on page 311.

Walls, Railings & Fencing

Walls are the single most important building component in Home Designer Essentials. By creating walls and defining the rooms created by the walls, you are telling the program how you want the 3D model built.

There are several ways that walls can be created in Home Designer Essentials. The most common is to simply draw them with the Wall Tools.

In addition, exterior walls can be generated automatically when a new floor is built by using another floor as a model. For more, see “Adding Floors” on page 172.

Another feature that can be used to generate walls automatically is the **House Wizard**. See “House Wizard” on page 366.

Chapter Contents

- Wall Defaults
- The Wall Tools
- The Deck Tools
- The Fencing Tools
- Exterior and Interior Walls
- Foundation Walls
- Railings
- Invisible Walls
- Hatch Wall
- Break Wall
- Drawing Walls
- Connecting Walls
- Displaying Walls
- Measuring Walls
- Editing Walls
- Aligning Walls
- Roof Directives in Walls
- Attic Walls
- Wall Type Definitions
- Wall Specification Dialog
- Railing and Fencing Specification Dialogs
- Wall Hatch Specification Dialog



Wall Defaults



Default Settings can be accessed by selecting **Edit> Default Settings**. Click on “Walls” and click the **Edit** button to open the **Wall Defaults** dialog.

The settings in the wall defaults dialogs determine what wall types are drawn when the different wall tools are used. It is a good idea to be familiar with these settings and how they relate to your style of building.

Exterior/Interior Wall Defaults Dialog

Specify which wall types are drawn using the **Exterior**  and **Interior Wall**  tools in the **Exterior/Interior Wall Defaults** dialog.

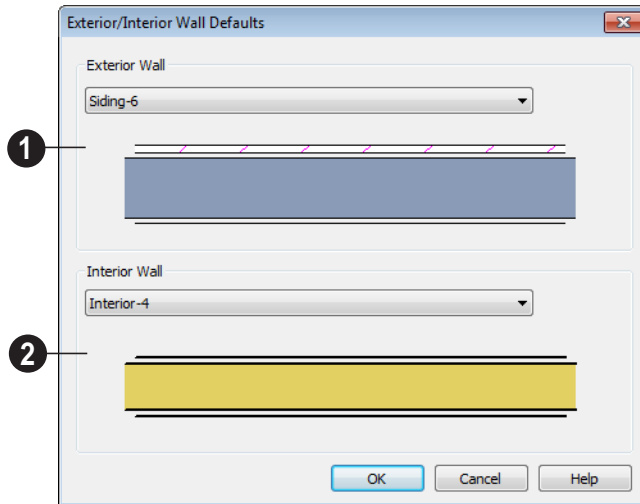

1 Exterior Wall Tool - From the drop-down list, select the wall type drawn with the **Exterior Wall**  tool.

2 Interior Wall Tool - From the drop-down list, select the wall type drawn by the **Interior Wall**  tool.

The Wall Tools

Select **Build> Wall** to access the Wall Tools. The type of wall drawn by each wall tool is

specified in its corresponding defaults dialog.

The **Curved Wall** tools are similar to their corresponding **Straight Wall Tools**. Select **Build> Curved Wall** to access these tools.

Exterior Walls



The **Exterior Wall** and **Curved Exterior Wall** tools draw walls using the default wall type specified for exterior walls in the **Exterior/Interior Wall Defaults** dialog. See “Exterior and Interior Walls” on page 99.

Interior Walls



The **Interior Wall** and **Curved Interior Wall** tools draw walls using the wall type specified for interior walls. The interior wall type is defined in the **Exterior/Interior Wall Defaults Defaults** dialog.

Note: Whether a wall is recognized as an exterior or interior wall by the program is determined by its position in the model, not by the tool used to draw it. See “Exterior and Interior Walls” on page 99.

Railings



The **Railing** and **Curved Railing** tools create railings. See “Railings” on page 100.

Invisible Wall



Invisible Walls are walls used to define separate room areas in a plan. They can display in floor plan view but not in 3D views. You can also convert a normal wall into an invisible wall and vice versa in the **Wall Specification** dialog. See “Invisible Walls” on page 101.

Hatch Wall



The **Hatch Wall** tool applies a hatch pattern to a wall that displays in floor plan views. You must click the wall that you want to apply the hatch pattern to. You can then select the hatch and resize it if you want to only hatch a portion of a wall. See “Hatch Wall” on page 102.

Break Wall



The **Break Wall** tool applies a break in a wall. Once a wall is broken, the two wall segments are separate walls that can be modified independent of each other. See “Break Wall” on page 102.

The Deck Tools



Select **Build> Deck** to access the Deck Tools. When a room is defined using deck railing, its **Room Type** is automatically set to “Deck”. See “Decks” on page 127.



Deck Railing



The **Straight Deck Railing** and **Curved Deck Railing** tools draw decks, complete with framing and bounded by a railing. If a foundation level exists, supports for the deck are also created. See “Railings” on page 100.

Deck Edges



The **Straight Deck Edge** and **Curved Deck Edge** draw decks complete with framing, but without a railing. No deck supports are created.

The Fencing Tools



Select **Build > Fencing** or click the **Fencing Tools** to access the fencing tools.





The **Fencing** and **Curved Fencing** tools are used to draw fences, which are similar to railings but by default do not define room areas. Fencing is created and edited much like walls and railings, and normally used outside of a building.



You can specify a fence panel style in the **Fencing Specification** dialog. See “Railing and Fencing Specification Dialogs” on page 116.

Exterior and Interior Walls

Most walls are drawn using either the **Exterior Wall**  or **Interior Wall**  tool. The only difference between these two tools is the wall type used. You can specify the default wall type for each tool in the **Wall Defaults** dialog.

To draw a wall using a different wall type, you can change the default wall type for

either tool in the **Wall Defaults** dialog. You can also draw a wall using the default type and then change the wall type in the **Wall Specification** dialog.

Whether a wall is recognized by the program as an actual exterior or interior wall is based on the model, not by which tool you use to draw the wall. Any wall that is entirely

surrounded by interior room areas is considered an interior wall. Any wall

exposed to the outside of the building is considered an exterior wall.

Foundation Walls

Foundation walls are similar to the interior and exterior walls but also have a footing. Foundation walls created automatically when a foundation floor is created. See “Building a Foundation” on page 179.



Railings





Railings are created and edited just like walls. See “Drawing Walls” on page 103.

Railings are ideal for a number of tasks:

- Creating changes in floor and/or ceiling height. See “Floor & Ceiling Heights” on page 128.
- Creating stairwells. See “Creating a Stairwell” on page 215.
- Drawing decks. See “Decks” on page 127.



To produce a break in a railing for a stairway or other access, use a **Doorway** . This keeps the railing continuous and maintains room definition. See “Room Definition” on page 121.

When first drawn, railings are specified as **No Locate**, which prevents **Auto Exterior Dimensions**  from locating them. The **No Room Def** attribute may also be helpful if

you do not want a railing to divide an area into two separate rooms. See “General Tab” on page 114.

Newels and balusters do not display in floor plan view.

Railing Types

A variety of railing types can be specified in the **Railing** and **Deck Railing Specification**

dialogs. See “Rail Style Tab” on page 117. Available types include:

- **Baluster** creates railings composed of newel posts, balusters, a railing, and an optional bottom rail.
- **Solid** produces a framed railing wall, or Half Wall.
- If **Panels** is selected, you can choose a panel style such as glass or ironwork from the library.

Invisible Walls



Invisible walls can display in floor plan view but not in 3D views or the Materials List. They are used to create or modify room definition, most often by defining smaller areas within larger rooms. See “Room Definition” on page 121.

Invisible walls can also be used to define areas with different floor or ceiling materials or heights.

Common uses for invisible walls include dividing areas of an open floor plan into areas with different purposes.

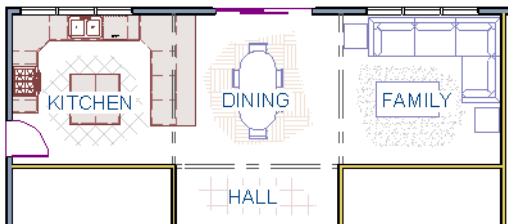

Invisible walls separate this dining area from adjacent rooms

An invisible wall can be turned into a normal wall, or vice versa, by clicking the **Invisible**

check box in its **Wall Specification** dialog. See “General Tab” on page 114.

Invisible walls are placed on the “Walls, Invisible” layer by default. A wall placed on a non-default layer and then specified as Invisible, however, will not move to the “Walls, Invisible” layer.

Important Notes on Invisible Walls

- Floor, wall and ceiling areas are calculated separately for rooms divided by invisible and normal walls.
- Invisible walls are ignored by the **Auto Place Outlets**  tool; it functions as though they were not present.
- Cabinets, fixtures and furniture can be moved freely through Invisible walls.
- Invisible walls can be drawn through a cabinet to attach to the wall behind.
- Invisible Walls are automatically generated to connect “island” rooms to the larger structure around them. See “Room Definition” on page 121.

Hatch Wall

 The **Hatch Wall** tool can be used to fill wall segments with a single hatch pattern in floor plan view.

To apply wall hatching, select **Build> Wall> Hatch Wall** , then click on a wall. The hatch pattern covers the entire length and width of the wall segment.

Note: The Hatch Wall tool cannot be used to apply a hatch pattern to Invisible Walls. See “Invisible Walls” on page 101.

Hatch Wall  places a hatch pattern across all layers of the selected wall, covering any fill styles specified for that wall type.

Once created, wall hatching can be selected, edited and deleted much like other line-based objects. See “Editing Line Based Objects” on page 73.

If you use the **Hatch Wall**  tool to apply a hatch pattern to a wall that has been divided into multiple segments using the **Break**

Wall  tool, the pattern is only applied to the segment that you clicked on. See “Break Wall” on page 102.

Like doors and windows, wall hatching cannot extend across multiple wall segments. Unlike these objects, hatching cannot be located by dimension lines.

The wall hatch pattern can be specified in the **Wall Hatch Specification** dialog. See “Wall Hatch Specification Dialog” on page 119.

When editing or deleting wall hatching, make sure that it is selected rather than the wall by noting that “Wall Hatching” displays in the Status Bar. See “The Status Bar” on page 23.

Break Wall

 To divide a wall or railing, select **Build> Wall> Break Wall** and click on the wall. The wall is divided into two wall sections at the point where you click.

The **Break Wall**  tool remains active, so you can continue to place breaks in walls. When you are finished, select a different tool.

If a wall break is placed near the intersection of two walls, the break is positioned at the center of the intersection.

Once a break is placed, click the **Select**

Objects  tool and select the original wall. If edit handles display near the break, the wall was correctly broken.

Walls separated by a break can be rejoined. Select one of the segments, then click on the end edit handle located at the break and drag it a few plan inches (mm) away from the break. See “Connecting Walls” on page 104.

The **Break Wall**  tool can be used to create aligned walls on either side of a gap. See “Creating a Nook” on page 110.

Drawing Walls

Walls are drawn by clicking and dragging from end to end and can be drawn in floor plan view, camera views, and overviews.

Drawing walls to create a floor plan is simple if you keep a few things in mind:

- Draw exterior walls first to define the building's footprint, then draw the interior walls after the perimeter is in place.
- It is easiest to draw walls at the approximate location and length needed and then move or resize them precisely using dimensions later. See "Moving Objects Using Dimensions" on page 350.
- As walls are drawn, "sticky" points identify points that are either collinear or orthogonal to the end points of other walls, making alignment easier. See "Extension Snaps" on page 64.
- When walls enclose an area to form a room, the program will orient all exterior walls so that the siding material faces outward.
- To flip the layers of a wall after it is drawn, select it and click the **Reverse Layers**  edit button. See "Editing Walls" on page 107.
- Initial wall heights are determined by the default floor and ceiling heights of the current floor.

Wall Positioning

The recommended method of drawing walls is to draw them at their approximate location and length, then move them into position

with accuracy using dimensions. To make this task quick and efficient:

- Notice the temporary wall that displays as you draw. Its length and angle display in the Status Bar at the bottom of the window and adjust as you move the mouse. Release the mouse button to draw the wall at the displayed length and angle. See "The Status Bar" on page 23.
- Use Snaps to help ensure proper wall alignment and orientation. See "Snap Behaviors" on page 63.

Once walls are drawn, they can be accurately dimensioned and moved as needed. See "Measuring Walls" on page 106.

Wall Openings

To create a door or doorway, do not draw wall sections with a gap between them. Walls should be drawn to completely enclose rooms, and then door and window objects should be placed in the walls to create openings later. See "Doors" on page 138 and "Windows" on page 154.

Masonry fireplaces placed in walls are also considered to be wall openings. See "Fireplaces" on page 184.

Temporary Dimensions

Temporary dimensions will display along the length of a wall as it is drawn, helping you draw walls to the desired length. Although dimensions display as you are drawing, you do not need to position walls precisely when you first draw them: they can be easily

moved into place at any time. See “Editing Walls” on page 107.

Drawing Curved Walls

To draw a curved wall or railing, select a curved wall tool, click at the point where you would like the wall to begin, then drag along the desired curve. Release the mouse button to create the wall.

A straight wall can also be converted into a curved wall and vice versa using the **Change**

Line/Arc  edit button. See “Change Line/Arc” on page 92.



To create a room in the shape of a circle, you must draw two curved walls.

House Wizard



The House Wizard allows you to place and arrange room “objects” that can then be converted into a fully editable house plan, including walls. See “House Wizard” on page 366.

Connecting Walls

When walls are drawn sufficiently close to one another, they will snap together to form an intersection. This snapping occurs when the walls’ center lines are within a distance defined by the larger of the two walls’ widths and will occur even when **Object Snaps** are turned off. See “Object Snaps” on page 63.

If the two walls in question have the same wall type and identical specifications, and are collinear, they will merge to become a single wall. See “Aligning Collinear Walls” on page 110.

When three or more walls connect to form a completely enclosed area, that area defines a room. See “Rooms” on page 120.

When walls snap together to form an intersection and **Object Snaps** are enabled, the program joins them at their Main Layers. See “Aligning Walls” on page 110.

- The wall that is being drawn or edited will move, lengthen, or shorten slightly to meet the other wall.

- The other wall will not move; however, its length may be affected.

Removing Wall Breaks

The **Break Wall**  tool allows you to break a wall into two or more separate wall segments. See “Break Wall” on page 102.

To merge two collinear walls separated by a break, select one of the segments, then click on the end edit handle located at the break and drag it a few plan inches (mm) away from the break.

If the two walls do not merge, either one or both walls have been moved and they are no longer collinear, or one or both has been edited in some way and they are no longer identical. Open the **Wall Specification** dialog for each wall and determine how they differ. See “Wall Hatch Specification Dialog” on page 119.

Displaying Walls



The display of walls in all views is controlled in the **Display Options** dialog. See “Displaying Objects” on page 59.

If a “Walls” layer is turned off, any doors and windows placed in walls on that layer will not display, either. See “Displaying Doors” on page 141 and “Displaying Windows” on page 159.

In Floor Plan View

There are several options for controlling how walls are displayed in floor plan view. In the **Display Options** dialog, you can specify whether or not various types of walls display. Walls are placed on layers with “Walls” at the beginning of the layer name, such as “Walls, Normal”.

Note: In floor plan view, railings not specified as Solid display their Main Layer regardless of whether “Walls, Layers” or “Walls, Main Layer Only” is turned on.

It is sometimes helpful to display the walls from a floor other than the current floor. To do this, select and display a reference floor. See “The Reference Floor” on page 176.

In 3D Views

As in floor plan view, the display of walls can be controlled by layer in the **Display Options** dialog.

While most architectural objects in the program can display in both floor plan and 3D views, a few cannot. Invisible walls and wall hatching are examples of objects that do not display in 3D.

Wall Materials

There are several ways that materials can be assigned to walls. See “Rooms” on page 120.

When you draw a wall, it uses the.

You can change the surface material of an individual wall in the **Wall Specification** dialog. If you select “Use Default” as the material and the wall is used to define a room, the program refers to the material specified in the **Room Specification** dialog. See “Wall Specification Dialog” on page 114.

You can also change a room’s wall material in the **Room Specification** dialog. See “Materials Tab” on page 303. To restore the default Wall Type material, select **Use Default** in the **Select Library Object** dialog. See “Select Library Object Dialog” on page 295.

Note: Wall materials that are specified on the Materials tab of either the Wall or Room Specification dialog are not calculated in the Materials List.

Measuring Walls

Accurate wall measurements are an essential aspect of any drawing, and can be achieved by following two basic rules:

- Be aware of what part of a wall assembly dimensions are locating;
- Position walls using dimensions rather than edit handles or edit tools.

These rules can easily be met when you keep the following recommendations in mind.

Use Dimension Defaults

Dimensions can be set to locate walls at their Main Layers or at surfaces. Before drawing dimensions - and particularly, before using them to move your walls into position - make sure that your Dimension Defaults are set up to meet your needs. See “Dimension Defaults Dialog” on page 342.

Edit Dimension Lines

Once a dimension line has been drawn, its extension lines can be edited to locate a number of locations on a wall assembly:

- The exterior surface
- The Main Layer’s exterior
- The center line of the wall assembly
- The Main Layer’s center line
- The Main Layer’s interior
- The interior surface

See “Editing Extension Lines” on page 349.

Moving Walls Using Dimensions

By far, the most precise method of positioning walls is using dimension lines. To produce accurate measurements, remember to:

- Be aware of what part of your walls is being located by dimensions.
- Avoid specifying dimension values with greater accuracy than your dimensions are set to display. See “Format Tab” on page 344.

See “Using Dimensions” on page 108.

Use Object, Angle and Grid Snaps

Object Snaps, Angle Snaps, and Grid Snaps make it easier to align walls when they are being drawn as well as when they are edited. See “Snap Behaviors” on page 63.

Object Snaps help to ensure consistent wall connections and are particularly helpful when aligning collinear walls.

When **Grid Snaps** are enabled, walls are drawn on a regularly spaced grid, which helps avoid inaccurate wall placement. This can become particularly important if you forego positioning walls using dimensions in favor of using edit handles to move them.

Angle Snaps make it easy to accurately draw walls at regular angles, ensuring walls that are truly parallel or perpendicular to one another and separated by consistent distances.

No Locate

If a wall is specified as **No Locate** in the **Wall Specification** dialog, it will be ignored by **Auto Exterior Dimensions**  in floor plan view, as will any doors or windows placed in it. By default, **Railings, Deck Railings, and Invisible Walls** are specified as No Locate. See “General Tab” on page 114.

The **No Locate** setting also affects the behavior of **Manual Dimensions**  and

End to End Dimensions . If a Manual or End to End Dimension is drawn between two No Locate walls, a dimension line will be created; however, if one of the walls is No Locate and one is not, no dimension line will be drawn. See “Dimensions” on page 342.



Once a dimension line has been created, it can be edited so that it locates a No Locate wall or railing that is perpendicular to it. See *Editing Dimension Lines*.

Editing Walls

Walls can be selected individually and as a group in all views. When a wall is selected, it displays edit handles and an edit toolbar that can be used to edit it in various ways. When a wall is selected, temporary dimensions will also display.

The ways in which a wall can be edited depends on the current view and which edge is selected. See “Selecting Objects” on page 71.

Selecting Walls

- When you try to select a wall in a 3D view, the interior or exterior room that it defines may be selected first. Click the **Select Next Object**  edit button or press the Tab key on your keyboard to select the wall itself.
- In floor plan view, if wall hatching has been applied to a wall using the **Hatch Wall**  tool, the hatching may be selected first. Click **Select Next**

Object  to select the wall itself. See “Hatch Wall” on page 102.

Using the Edit Handles

Depending on the type of view, a wall displays a different set of edit handles when selected.

- In floor plan view, straight and curved walls can be edited like other line- and arc-based objects. See “Editing Line Based Objects” on page 73 and “Editing Arc Based Objects” on page 75.
- In a camera view or overview, click on the top surface of a wall to display the same edit handles as in floor plan view, allowing you to rotate, move, and extend or shorten the length of the wall.
- Moving a wall in any view will move any cabinets attached to that wall, as well.
- In an Elevation view, the side edges of straight walls can be moved to shorten or lengthen the segment. Curved walls can

be shortened in this manner, but not lengthened.

- In a camera view or overview, click on an interior or exterior surface to display an edit handle at the center of each side edge, allowing you to shorten or lengthen the wall. Curved walls can be shortened in this manner, but not lengthened.
- When a wall is connected to other walls it can only be moved perpendicular to itself or, in the case of curved walls, perpendicular to its chord using the Move edit handle.

In the Specification Dialog



The appearance and structure of walls can be customized in the **Wall Specification** dialog. See “Wall Specification Dialog” on page 114.

The characteristics of the roof directly above a selected wall can also be specified in the **Wall Specification** dialog. See “Roof Tab” on page 115.

Using the Edit Tools

A selected wall or walls can be edited in a variety of ways using the buttons on the edit toolbar. See “The Edit Toolbar” on page 21.

The characteristics of the roof directly above a selected wall can also be specified in the **Wall Specification** dialog. See “Roof Tab” on page 115.

Using Dimensions



Automatic, manually-drawn, and temporary dimension lines can be used to both resize and move walls with

accuracy. Select a wall, then click on a dimension line that locates it and type in the value that you need. See “Moving Objects Using Dimensions” on page 350.

When a wall is resized using dimensions, the inline text field used to edit the dimension will have three unique buttons: **Move Start**, **Move End**, and **Move Both Ends**. Choose the option that you want to use before pressing the Enter key.

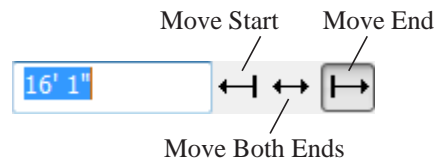

If both ends of the selected wall intersect walls that are not parallel to one another, a fourth option will be available: **Move Along**

Rails . When this option is used, the selected wall both resizes and changes position so that it remains connected to the other walls when you press the Enter key.

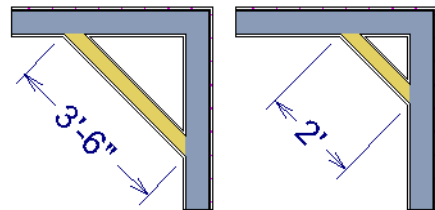

Move Along Rails resizes and moves a selected wall.

Depending on your **Dimension Defaults** settings, dimension lines may locate wall surfaces or Main Layers. See “Dimension Defaults Dialog” on page 342.

Wall Thickness

The initial thickness of a wall is determined by its wall type.

You can specify a selected wall's thickness in its **Wall Specification** dialog. See "General Tab" on page 114.

If a selected wall's thickness is changed:

- A copy of the wall's wall type is created with the same name but appended with a number equal to the thickness of the structural layer, and that new type is assigned to the wall.
- The change in thickness will be applied to new wall type's structural layer.
- The structural layer must be at least 1/16" thick, and the wall's thickness cannot be less than the original wall type's total thickness minus the thickness of its structural layer.

If a wall type's thickness is modified, the wall will resize about the outside edge of its Main Layer. In some instances, the wall may appear to move as a result of changes made to the thicknesses of its layers.

Wall Heights

The height of a wall is controlled by the ceiling height of the room(s) it defines. If the ceiling or floor height of a room is changed, the height of the walls that define it also change.

- The initial ceiling height for all rooms on a floor is set in the **Floor Defaults** dialog for that floor. See "Floor Defaults" on page 121. Whenever possible, it is best to set all ceiling heights using the default.
- The ceiling height of a single room can be set in its **Room Specification** dialog. See "General Tab" on page 131.

Wall Length

Wall length can be modified in several different ways:

- Using dimensions. See "Measuring Walls" on page 106.
- In the **Wall Specification** dialog. See "General Tab" on page 114.
- By dragging the end edit handles. See "Editing Line Based Objects" on page 73 and "Editing Arc Based Objects" on page 75.

Bear in mind that if you try to resize a wall by a small amount using one of its edit handles and that wall is connected to another wall at that end, its length will not change because its end will snap back to the existing intersection. See "Connecting Walls" on page 104.

The most accurate way to specify wall length is using dimensions. By default, wall length is measured at the outside edge of the Main Layer. You can instead specify that dimension lines locate surfaces in the **Dimension Defaults** dialog. See "Dimension Defaults Dialog" on page 342.

Editing Straight/Curved Wall Combinations

If you move a straight wall connected to a curved wall with a locked center, the curved wall extends along its curve and the straight wall will either lengthen or shorten as needed to stay connected to the curved wall.

If the connection between the straight and curved wall cannot be maintained because of the curved wall's radius, it will be broken.

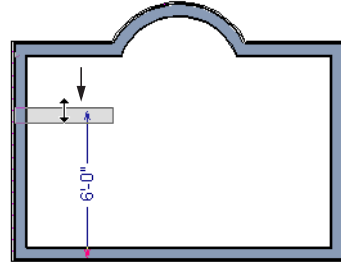

Aligning Walls

Wall alignment refers to the way wall segments line up with one another, either on the same floor or on the floor above or below. Walls may need to be aligned in a variety of situations.

To make alignment easier when drawing or resizing walls, “sticky” points identify points that are either collinear or orthogonal to the end points of other walls. See “Extension Snaps” on page 64.

Aligning Collinear Walls

Collinear walls are parallel walls connected end to end and drawn on the same floor. When collinear walls join end-to-end, the walls snap together. If these walls have the same wall type and identical specifications, and if **Object Snaps** are enabled, they will merge to become a single wall segment.

Creating a Nook

Walls can be aligned across an opening such as a nook, so that they are collinear, using the

Break Wall  tool.

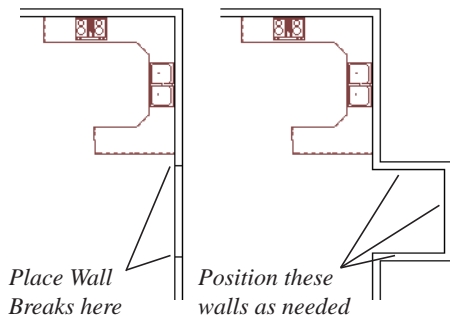

To align walls across a gap

1. Select a wall to build a nook into and click the **Break Wall**  edit button.
2. Click at a point on the wall close to one side of the nook area. Do not worry about exact placement right now.
3. Click again near the other side of the nook. Two short lines at each location where you clicked indicate Wall Breaks.





4. Right-click the middle section of the wall to select the wall section.
5. Click the middle Move handle and drag the wall outward.
6. Draw side walls to connect the wall back to the rest of the house.
7. Move these short walls using dimensions to accurately size the nook.

Aligning Walls Between Floors



Walls can be aligned between floors by clicking the **Align With Wall Above**  and **Align With Wall Below**  edit buttons.

 In order for these edit tools to be available, the areas of the walls in question must be partially aligned, or overlapping.

To align walls between floors

1. Select a wall that you want to align with another wall either above or below it.
2. If the wall is above or below the other wall along only part of its length, you must click on it along that part. Select **Tools > Reference Floors > Reference Display On**  to help make sure you click on the correct part of the wall.
3. When you have selected the wall at the desired location, click either the **Align With Wall Above**  or **Align With Wall Below**  edit button.

Aligning Curved Walls Between Floors

Curved walls are aligned between floors using the same technique to align straight walls. If the centers and radii of the walls are within a few inches of each other, the **Align With Wall Above**  and **Align With Wall Below**  edit buttons are enabled for the selected wall. The selected curved wall will take on the radius and center of the referenced wall when the walls are aligned.



Roof Directives in Walls

To automatically generate a roof plane using values other than the defaults or to not generate a roof plane bearing on a particular wall (as for a gable or the sides of a shed

roof), you can change the settings in the **Wall Specification** dialog. See “Roof Tab” on page 115.

Hip, Gable, and Shed Roofs

By default, the program will produce a roof plane over each exterior wall to create a hip roof. You can instead specify a gable or shed roof above the selected wall.

- Check **Full Gable Wall** to create a gable with a ridge centered above the selected wall(s).
- Check **High Shed/Gable Wall** for the side walls or the wall under the high side of a shed roof.
- You can also select a wall and click the **Change to Gable Wall(s)**  edit button, or change it back by clicking the **Change to Hip Wall(s)**  edit button.

Pitch

The default pitch for roof planes is set in the **Build Roof** dialog. However, any exterior wall can define the pitch of the roof plane built above it.

You can also specify a second, upper pitch above a given wall. Mansard, gambrel, gull wing and half-hip are examples of roof styles that use two pitches. See “Roof Tutorial” on page 61 of the User’s Guide.

Extend Slope Downward

Check **Extend Slope Downward** to extend the roof plane downward over a bumpout,

instead of creating additional roof planes. The two connecting walls that create the bumpout must be Full Gable walls.

In the following image, the bearing wall of the bumpout has **Extend Slope Downward** checked. The two short side walls are **Full Gable Walls**.

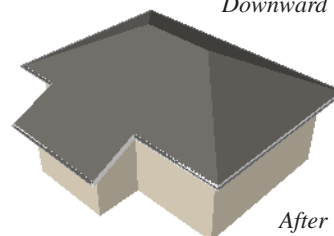
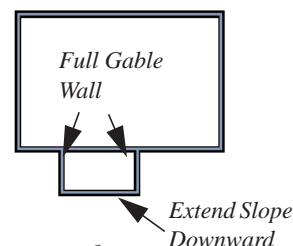
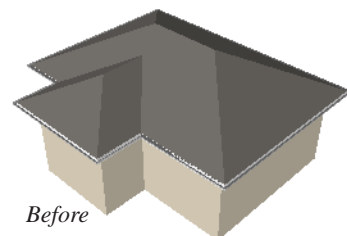

Attic Walls

In Home Designer Essentials, walls are built between the floor and ceiling platforms of the current floor. See “Floor & Ceiling Heights” on page 128. When the program

detects an open space between a wall and the roof plane above it, it automatically creates an Attic Wall on the floor above that wall to fill in the gap.

Attic Walls are typically found above Full Gable Walls, forming a gable or closing the top portion of a side wall of a shed roof. Attic walls are often found on the Attic floor, but can be generated on other floors, as well. See “The Attic Floor” on page 176.



If you do not want to keep a particular Attic Wall in your plan, specify it as Invisible. See “Invisible Walls” on page 101.

Knee Walls

Knee Walls are a bit like Attic Walls in that they are not meant to generate to full ceiling

height. Instead, they build upward until they encounter a roof plane. Unlike Attic Walls, however, Knee Walls are used in the interior of a structure, typically to separate unused areas from rooms on the upper floor of a story-and-a-half structure. See “Room Types” on page 124.

Home Designer Essentials does not specify walls as Knee Walls automatically. If an interior wall is drawn in a location where the roof is lower than the ceiling height, you should specify it as a Knee Wall in the **Wall Specification** dialog. See “Roof Tab” on page 115.

Wall Type Definitions

Every wall drawn in a plan is assigned a wall type, and its Wall Type Definition determines its structure, its appearance in floor plan view, and its default materials.

You can specify the default wall types used when walls are first created, and can specify the wall type of any wall after it is drawn in the **Wall Specification** dialog. See “Wall Defaults” on page 97 and “General Tab” on page 114.

The structural layer of a wall type is its Main Layer, which controls a number of things:

- At intersections, walls join at the interior surfaces of their Main Layers. See “Connecting Walls” on page 104.
- Exterior walls on different floors are aligned by the exterior edges of their Main Layers.
- Roof baselines are placed at the outer edge of the Main Layer.

- Walls resize about the exterior surface of their Main Layer when their wall type is changed.
- Object Snaps locate the exterior surface of a wall’s Main Layer. See “Object Snaps” on page 63.
- By default, dimension lines locate walls at their Main Layer. See “Dimension Defaults Dialog” on page 342.

Interior and Exterior Surfaces

Every wall has an interior and exterior surface - including walls in a plan that are recognized by the program as being interior walls. See “Exterior and Interior Walls” on page 99.

Having separate designations for a wall’s two surfaces allows you to specify different materials for each in the **Wall Specification** dialog. See “Materials Tab” on page 116.

In floor plan view, you can identify a selected wall's exterior surface by the

location of its edit handles, which display on the exterior of the Main Layer.

Wall Specification Dialog



To open the **Wall Specification** dialog, select a wall and click the **Open Object** edit button.

The tabs of the **Wall Specification** dialog are also found in the **Railing**, **Deck Railing**, and **Fencing Specification** dialogs. See “Railing and Fencing Specification Dialogs” on page 116.

General Tab

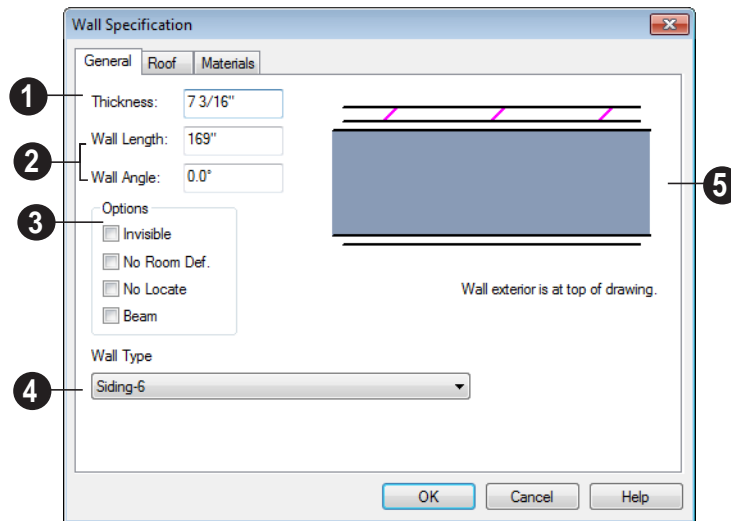

Some items on the General tab are available only when they apply to the selected wall or railing.

1 The **Thickness** of the selected wall displays and can be changed here. If the wall is a Post to Overhead Beam railing, this setting also affects the width of the beam. See “Wall Thickness” on page 109.

2 Specify the **Wall Angle** and **Wall Length** of a straight wall. These options are not available for curved walls.

- **Wall Angle** - The current absolute angle of the wall in a floor plan view is shown. Type in a new angle to rotate the wall about its locked point.
- **Wall Length** - The current length is shown. Type in a new length. The part of

the wall that extends or contracts is determined by where it is locked.

- 3 Check any of the **Options** to modify the selected wall accordingly. In most cases, multiple options can be selected. Not available for fencing.
 - Select **No Room Def.** to display the wall in floor plan and/or 3D views but not create room definition. See “Room Definition” on page 121.
 - Select **No Locate** to prevent Auto Exterior Dimensions from locating a wall. Railings have No Locate selected by default. See “No Locate” on page 107.

- Select **Beam** to have the wall display as two lines in floor plan view and a beam in 3D views.

- 4 The **Wall Type** drop-down allows you to change the type of the wall currently selected to any of the available options. Its graphic representation in the upper right corner will update to reflect the wall type that is currently selected. Not available for fencing.

- 5 A preview diagram of the selected wall type displays here.

Roof Tab

Any automatically generated roof style other than a hip requires roof information to be defined in the exterior walls. On the Roof tab, you can specify how the selected wall interacts with the roof plan, defining the portion of the roof plan that bears on it..

The Roof tab is not available for Foundation Walls or Fencing. See “Foundation Walls” on page 100 and “The Fencing Tools” on page 99.

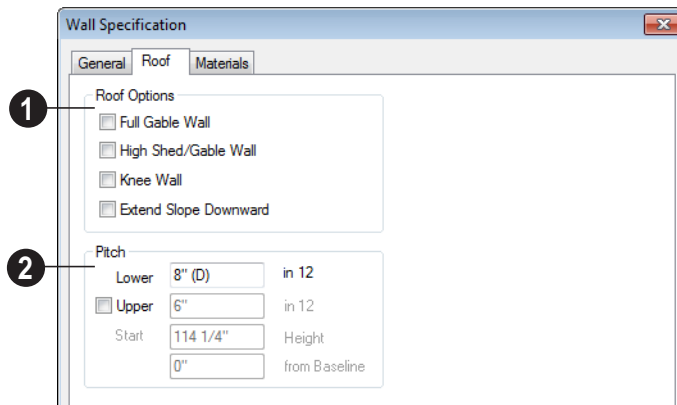

- 1 **Roof Options** - Specify the shape of the wall relative to the roof.

- Check **Full Gable Wall** to create a gable end over the selected wall.

- Check **High Shed/Gable Wall** to specify the selected wall as the high end of a shed roof.
 - Check **Knee Wall** to define the selected interior wall as a knee wall. Only an interior wall can be defined as a knee wall. A knee wall's height is defined by the roof above, not the ceiling height. See “Knee Walls” on page 113.
 - Check **Extend Slope Downward** to continue a roof down over a bumpout in an exterior wall. See “Extend Slope Downward” on page 112.
- 2 Pitch Options** - Specify the pitch or pitches of the roof plane(s) above the selected wall.
- Enter a value to define the **Pitch** of the roof plane bearing on the selected wall.
 - Check **Upper Pitch** to create a roof with two pitches or, if the selected wall is a Full Gable Wall, a half hip condition.
 - Enter the **Pitch** of the second, upper roof.
 - Specify the **Height** that the Upper Pitch **Starts at**, or define the distance **in from Baseline** that the second pitch begins. The two values are dynamic. Press the Tab key to update the relative numbers.

Rail Style Tab

The Rail Style tab is only available for Railings and Deck Railings. See Rail Style Tab.

Fence Style Tab

The Fence Style Tab is only available when a Fence object is selected. See “Fence Style Tab” on page 118.

Materials Tab

All walls - including interior walls, railings and fencing - have an “Exterior Wall Surface” and an “Interior Wall Surface”. See “Interior and Exterior Surfaces” on page 113.

The materials specified on the Materials tab affect the appearance of walls and Solid Railings in 3D views but are not calculated in the Materials List. See “Materials Lists” on page 392.

For most railing types, the “Exterior Wall Surface” component only affects the appearance of the floor platform under the railing, and “Interior Wall Surface” component is not used. For fencing, neither material component is used.

Railing and Fencing Specification Dialogs



To open the **Railing or Fencing Specification** dialog, select a railing or fencing and click the **Open Object** edit button.

The **Railing and Fencing Specification** dialogs are the same as the **Wall Specification** dialog, but have tabs that apply only to Railings, Deck Railings, and Fencing. See “Wall Specification Dialog” on page 114.

Rail Style Tab

The Rail Style tab is only available for Railings and Deck Railings. See “Railings”

on page 100 and “The Deck Tools” on page 98.

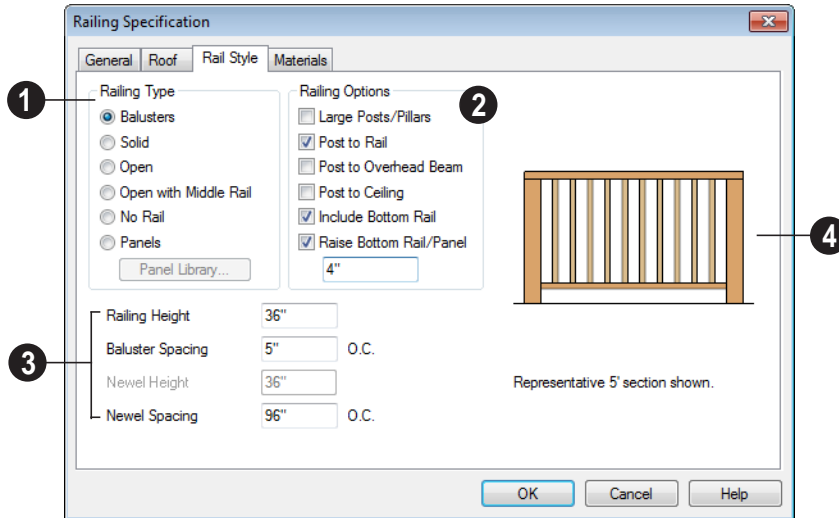

1 Railing Type - Select the radio button for the desired railing type. A preview of the selected type displays to the left.

- **Balusters** - Create regularly spaced balusters between larger newel posts.
- **Solid** - Create a solid, wall style railing. The wall is the type defined by the current wall layer definition.
- **Open** - Create a railing with only a top rail.
- **Middle Rail** - Create a railing with a top and a middle rail.
- **No Rail** - Eliminate rails, leaving only posts (and overhead beam, if selected).
- **Panels** - Add panels between the newel posts.
- Click the **Panel Library** button to select a style of panel from the library. Options

include glass and ironwork panels. See “Select Library Object Dialog” on page 295.

- 2 Railing Options** - Specify how newel posts and the bottom rail are generated.
- **Post to Rail** - Create newel posts from the floor to the bottom of the railing. This option is selected by default.
 - **Post to Overhead Beam** - Create newel posts from the floor to an overhead beam placed just under the ceiling height. The beam’s width is based on the Thickness of the selected railing wall.
 - **Post to Ceiling** - Extend the newel posts to the ceiling.
 - When none of the Post options is selected, newel posts will build to the top of the railing.

- Uncheck **Include Bottom Rail** to eliminate the bottom rail and extend the balusters to the floor. Not available for Panel railings.
- Check **Raise Bottom Rail**, then specify the bottom rail's height off the floor platform in the text field below.
- ③ Specify the heights and on-center spacing of the railing's components.
- Specify the **Railing Height** which, for interior railings, is measured from the height of the floor finish.
- Specify the **Baluster Spacing**, measured from baluster center to baluster center.
- Specify the **Newel Height**, which is the height from the ground to the top of the newel. Not available if Post to Rail, Post to Overhead Beam or Post to Ceiling is selected on the Rail Style tab. See "Rail Style Tab" on page 117.
- Specify the **Newel Spacing**, measured from newel center to newel center.
- ④ A preview of the railing displays here and updates as options are changed.

Fence Style Tab

The Fence Style Tab is only available when a Fence object is selected. See "The Fencing Tools" on page 99.

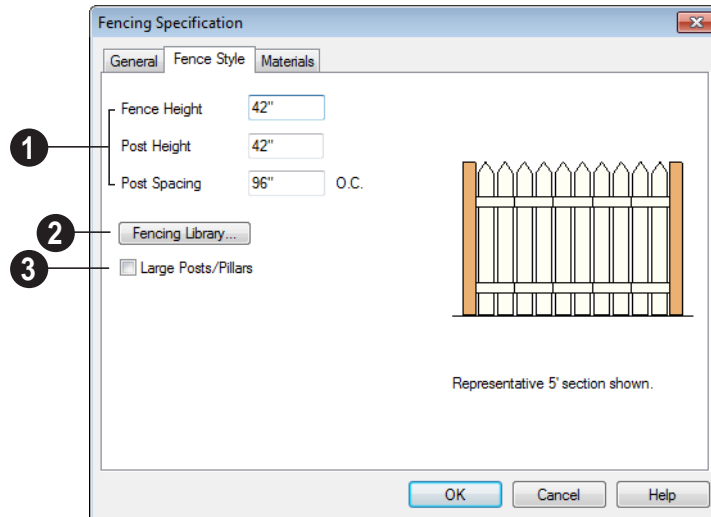

- ① Specify the size of the fencing components.
- Specify the overall **Fence Height**, from the ground to the top.
- Specify the **Post Height**, which can be greater than, less than, or the same as the overall Fence Height.

- Specify the **Post Spacing**, which is the distance from the center of one post to the next.
- ② Click the **Fencing Library** button to specify a style of fence panel from the library. See “Select Library Object Dialog” on page 295.

- ③ Check **Large Posts/Pillars** for the selected fencing to have posts that are 50% wider than the selected fencing’s Thickness value. When unchecked, the posts are the same width as the Thickness.

Wall Hatch Specification Dialog



To open the **Wall Hatch Specification** dialog, select a Wall Hatch and click the **Open Object** edit button. See “Hatch Wall” on page 102.

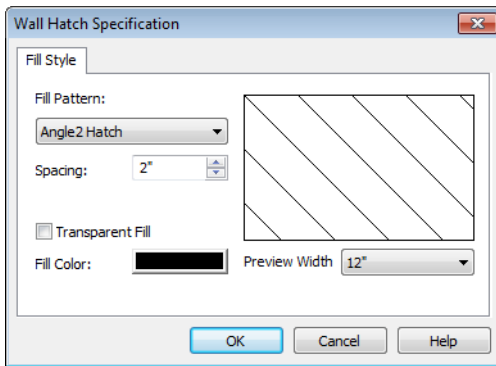

- Choose a **Fill Pattern** from the drop-down list. A preview of the selected pattern displays to the right.

The options that follow are disabled until

you select a pattern other than **None** from the **Fill Pattern** drop-down list.

- Define the **Spacing** for the selected fill pattern. Hatch spacing set at 12" matches grid/reference spacing set at 12".
- Check **Transparent Pattern Fill** to make the fill pattern transparent. When you check this option, any objects behind the fill pattern are visible through it.
- **Fill Color** - Click the color bar to select a color for the fill pattern lines or fill color if a solid fill is specified. This overrides the layer color. See “Color Chooser Dialog” on page 309.
- Choose a **Preview Width** from the drop-down list. This value controls how large an area the preview represents. The selected value indicates the length of each side of the preview in plan inches (mm).

Rooms

When walls or railings create an enclosed area, a “room” is created. You can select rooms defined in this manner like other objects in Home Designer Essentials.

Rooms are assigned a Room Type. Each Room Type has predefined characteristics. For example, a room defined as Porch is assigned certain attributes that are different than a Kitchen.

Floor and ceiling heights, baseboard, chair-rail, and crown moldings and materials can be defined room-by-room or for the entire floor.

Chapter Contents

- Floor and Room Defaults
- Room Definition
- Selecting Rooms
- Displaying Rooms
- Editing Rooms
- Room Types
- Room Labels
- Decks
- Floor & Ceiling Heights
- Special Ceilings
- Room Specification Dialog

Floor and Room Defaults



Select **Edit> Default Settings** to open the **Default Settings** dialog where you can access several defaults dialogs which directly affect rooms.

Floor Defaults

Default values for rooms are specified in the **Floor Defaults** dialog for the current floor. This dialog also controls important information that the program uses to create 3D models - particularly floor and ceiling heights and materials. Moldings can also be specified in the **Floor Defaults** dialog.

Only the defaults for the first floor of a building can be set ahead of time. The program uses the setting from the first floor to create subsequent floors. Once a new floor is built, its floor defaults can be changed. See “Floor Defaults Dialog” on page 171.

Room Defaults

Additional material defaults for several categories of Room Types can also be specified:

- Normal Rooms
- Kitchens/Baths/Utility Rooms
- Decks
- Garage/Porches/Slabs

These Room Defaults dialogs are accessed by expanding the “Rooms” category in the **Default Settings** dialog. Select a room type and click the **Edit** button to open the defaults dialog for that room type. See “Room Types” on page 124.

These dialogs allow you to specify the floor and ceiling covering materials for different Room Types.

Room Definition

A room is a totally enclosed area defined by any combination of joined walls or railings, visible or invisible. To be recognized as a room by Home Designer Essentials, a room must have an unbroken perimeter.

Unless otherwise specified, rooms generate floor and ceiling platforms automatically. Most rooms are also automatically covered by the roof when one is built. There are exceptions to this, such as rooms defined as Decks. See “Room Types” on page 124.

If a room is drawn within a larger structure and none of its walls connect to the exterior walls, either directly or indirectly by

connecting to walls that do, it is referred to as an “island” room. The program will connect such a room to the larger structure with an Invisible Wall. See “Invisible Walls” on page 101.

Room definition disappears if part or all of a surrounding wall is deleted. It is a good idea to finalize the position of walls before defining rooms with names and attributes such as floor height and ceiling height.

Subdividing Rooms

When a room area is first defined, it inherits its characteristics from the **Floor Defaults**

dialog for that floor. If the room is then specified as a particular type, it may inherit properties from the **Room Defaults** dialog associated with its type.

If a new room is created by subdividing a larger room, it inherits its characteristics from that larger room - including any non-default settings.

Selecting Rooms

Room definition is established when a room is completely enclosed by walls. You can confirm that a room has room definition by using the **Select Objects**  tool to select it. When a fully-enclosed room is selected, the room highlights.



The room at left is selected

The Exterior Room

You can also select the exterior of a model. This allows you to control the building's exterior wall coverings and materials using the **Room Specification** dialog.

Click just outside an exterior wall using the **Select Objects**  tool to select the Exterior Room. When it is selected, a highlighted band around the plan's exterior displays. This band represents the selection area for the Exterior Room.

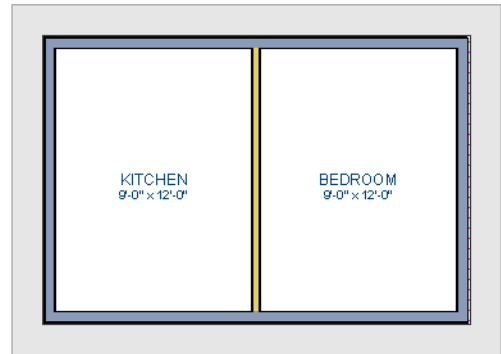

The Exterior Room is selected

In camera views and overviews, the Exterior Room can be selected by clicking on the exterior surface of an exterior wall using the **Select Objects**  tool.

In 3D Views

Click on the floor of a room or on a wall surface inside the room in a 3D view using the **Select Objects**  tool. If you select another object instead of the room, click

Select Next Object  edit button or press the Tab key until the room is selected. The Status Bar indicates which object is currently selected.

The Exterior Room can also be in 3D views selected by clicking once on the exterior

surface of an exterior wall using the **Select Objects**  tool.

Note: If the wall height of the Exterior Room is adjusted in a 3D view, the default Floor or Ceiling Height of the entire floor is changed. See “Floor and Room Defaults” on page 121.

Displaying Rooms

Unlike most things in Home Designer Essentials, a room is not an individual object. Rather, a room is defined by the walls that enclose it.

In Floor Plan View

Rooms typically display a transparent fill in floor plan view. You can, however, specify a solid color or fill pattern for individual rooms in the **Room Specification** dialog. See “Fill Style Tab” on page 135.

In order for room fill styles to display, the “Rooms” layer must be turned on. See “Displaying Objects” on page 59.

Room labels that include the room’s name as well as its size and other information can be set to display in floor plan view. See “Room Labels” on page 126.

In 3D Views

Rooms can be viewed in 3D views created by any of the 3D view tools. The **Dollhouse View** tool can be used to see all rooms on the current floor without their ceilings. See “Creating Overviews” on page 321.

Editing Rooms

Once a room is defined by walls or railings, its structure and appearance can be edited using the edit buttons or the **Room Specification** dialog.

In 3D Views

The floor and ceiling heights for floors and rooms can be edited using edit handles in 3D views. Lowered ceilings cannot be edited in 3D. See “3D Views” on page 318.

The default floor and ceiling heights for an entire model can be edited by selecting the

Exterior Room. See “The Exterior Room” on page 122.

To change default ceiling heights in 3D

1. Create a 3D view of the exterior of your plan.
2. Click on the exterior surface of a wall to select the Exterior Room. The Status Bar indicates when the exterior room is selected. See “The Exterior Room” on page 122.
3. Click and drag the edit handle on the top wall edge to adjust the default ceiling

height, or the edit handle on the bottom edge to adjust the default floor height. Temporary dimensions display.

Note: Any rooms that do not update when the default floor or ceiling height is changed are not using the default values. To use the default values for a specific room, check Default for any of the room height values in its specification dialog. See “General Tab” on page 131.

To adjust room heights in 3D

1. Create a 3D view of your plan.
2. Click on the surface of a wall that faces the room to select it. When the room is selected in 3D:
 - The room highlights.
 - The Status Bar says “Room”. See “The Status Bar” on page 23.

- Two edit handles display on the top and bottom edges of the highlighted wall.
3. Click and drag the edit handle on the top wall edge to adjust the room ceiling height, or the handle on the bottom edge to adjust its floor height. Temporary dimensions display.
 4. As you drag a handle, notice that all walls defining that room are affected.

Room materials such as floor, ceiling, and wall materials can be changed in 3D views using the **Material Painter** . See “The Material Painter” on page 301.

In the Specification Dialog



Floor and ceiling heights, floor platform structure, moldings, and materials can all be specified in the **Room Specification** dialog. See “Room Specification Dialog” on page 131.

Room Types

When a room is first created by enclosing an area with walls, it is assigned a generic room type of “Unspecified.”

Once your floor plan is laid out, each room should be assigned a **Room Type** in the **Room Specification** dialog. See “General Tab” on page 131. The Room Type applies appropriate structural and display properties to the room.

When you assign a Room Type, a label showing the room’s Type displays in floor plan view.

You can edit the text of a room label in floor plan view, but the type of room originally

assigned remains until it is changed in the **Room Specification** dialog. See “Editing Room Labels” on page 126.

Available Room Types

There are three categories of room types: Interior, Exterior and Hybrid.

Interior - Living, Dining, Family, Kitchen, Nook, Bath, Master Bath, Master Bedrm, Bedroom, Study, Office, Entry, Hall, Closet, Dressing, Storage, Laundry, Utility and Unspecified.

Exterior - Court, Deck, Balcony.

Hybrid - Open Below, Garage, Slab, Porch, Attic.

Effects of Room Types

The program applies specific structural and display properties to rooms depending on the assigned Room Type.

Living Area

- All interior type rooms are included in Living Area calculations; exterior and hybrid rooms are not.

Ceilings and Roofs

- Interior rooms have a ceiling and roof above them unless specified otherwise.
- Exterior rooms are assumed to be open to the outside and do not generate a roof above them, or room moldings.
- Attic rooms are ignored by the program's automatic roof generator.
- Garage, Slabs, and Porches are treated like exterior rooms in all cases except that they generate a ceiling and a roof above them.
- A room's default ceiling structure and finish definitions are determined by its Room Type. See "Room Defaults" on page 121.

Floors and Foundations



- Open Below is a unique type of interior room. It has no floor platform and can be used for defining stairwell openings.
- Walls that define the garage have a foundation under them with a concrete slab at the top of stem wall or grade beam.
- The floor in Garage and Slab rooms display in 3D on Floor 0, not the first floor. See "Garages" on page 182.

- A room's default floor structure and finish definitions are determined by its Room Type. See "Room Defaults" on page 121.
- Courts, decks and balconies do not generate foundations.

Doors and Windows

- A window placed in a wall between an exterior room and an interior room always faces out toward the exterior.
- Windows placed between interior rooms generate a warning message.
- Door placed between interior and exterior type rooms display threshold lines.
- Interior doors do not display thresholds.
- Open Below rooms are treated as interior rooms for window and door placement.

Electrical

- The **Auto Place Outlets**  tool adds outlets automatically to all interior rooms except bathrooms. Only one outlet over each sink is added for a bathroom.
- The **Auto Place Outlets**  tool places fewer outlets in hybrid rooms.
- The **Auto Place Outlets**  tool does not place outlets in exterior type rooms, Porches or Open Below rooms.
- Any outlet manually placed in an exterior room automatically becomes a waterproof outlet designed for exterior use.

Trim and Molding

- Moldings are not automatically drawn in exterior or hybrid rooms.
- Baseboards and chair rails are not initially drawn in Open Below rooms, but crown molding, if present, is.

Plan Check

- **Plan Check**  uses the room type and its characteristics for basic plan checking.

For example, a closet does not need a smoke detector but a bedroom does. See “Plan Check” on page 368.

Room Labels

A label can display in floor plan view for any area defined as a room. There are two parts to each room label:

- The Room Name, which is similar to a **Text**  object and can be selected and edited. See “The Text Tools” on page 355.
- The room area, which is not a standard text entry and cannot be directly edited.

You can assign a custom Room Name, move a room label or even delete it without affecting the Room Type. See “Room Types” on page 124.

 Room labels can move or even disappear when room entries are revalidated.

Displaying Room Labels

The display of room labels is controlled in the **Display Options** dialog. Room labels are placed on the “Rooms, Labels” layer and use the Text Style assigned to that layer. See “Display Options Dialog” on page 60.

You can specify how the area of rooms is calculated by the program by turning on the display of one or more of these layers:

- **Rooms, Standard Area** is measured from the center of interior walls to the exterior wall framing. It is rounded to the nearest square foot or mm and does not include the area within bay, box and bow windows.

- **Rooms, Interior Area** is measured from the inner surfaces of all the room's walls.
- **Rooms, Interior Dimensions** is also measured from the inner surfaces of the room walls.

Editing Room Labels

Room labels are similar to simple **Text**  objects and can be changed, moved and resized much like any other text object. You can also modify a room label's Text Style and other attributes in the **Room Label Specification** dialog.

The text of a room label cannot be modified in its specification dialog, however: it must be specified in the **Room Specification** dialog. See “General Tab” on page 131.

If you delete a room label, the Room Type and Room Name remain unchanged in the **Room Specification** dialog. To restore the label, check the **Show Room Label** check box on the General tab of that dialog.

Room Area

Unlike the rest of a room label, the room area and dimensions are not standard text entries and cannot be edited or changed. The room area moves, resizes and rotates with the rest of the room label, but you can turn the area and dimensions on or off separately in the

Display Options dialog. See “Displaying Rooms” on page 123.

The **Interior Area** room area calculation includes the areas within bay, box or bow windows, while the Standard Area and Interior Dimensions calculations do not.

Living Area

The **Living Area** label displays the area of the floor platform for living areas in a plan. It is found near the bottom center of the plan as soon as a room area is defined by walls and/or railing.

The Living Area displays for an individual building if half or more of that building's area is living area. For example, a living area label would not display for a detached garage that contains a bathroom or small shop.

You can choose not to display this label by turning off the display of the Room Labels layer in the **Display Options** dialog.

The Living Area label can be moved or deleted. To restore a deleted Living Area label, select **Tools> Plan Check** . You can click the **Done** button immediately, without actually completing Plan Check. See “Plan Check” on page 368.

Living Area vs. Footprint

The Living Area should not be mistaken for the footprint of the house. Only true livable areas are included in the Living Area calculation. Exterior and hybrid room types such as Garage, Deck, and Porch are not included. Neither is any room labeled Open Below or Attic. See “Available Room Types” on page 124.

Living Area is measured from the outer surface of the structural layer of exterior walls. When walls separate the living area from exterior or hybrid room types, it is measured to the wall center line.

Decks

A Deck room is an exterior-type room that uses deck planking and framing to create a floor platform rather than using a single floor surface that spans the entire room area.

To draw a deck, select **Build> Deck> Deck Railing** , then click and drag to draw a railing.

- To create a deck without a railing, use one of the **Deck Edge** tools. See “The Deck Tools” on page 98.

A room does not have to be defined by Deck Railing to be specified as a “Deck.” See

“Room Types” on page 124. You can also define a room as a “Deck” in the **Room Specification** dialog. See “General Tab” on page 131.

By default, decks do not have roofs. If you want a roof over a deck, check **Roof Over This Room** in the **Room Specification** dialog. See “Structure Tab” on page 132.

To give the roof a visible means of support, you can select the **Post to Beam** option in the **Wall Specification** dialog. See “Rail Style Tab” on page 117.

Openings in deck railings can be created using **Doorways** . See “Openings in Railings” on page 146.

Floor & Ceiling Heights

Use the **Room Specification** dialog to set floor heights on a room-by-room basis. See “Room Specification Dialog” on page 131.

Different rooms on the same floor can have unique floor and ceiling heights, allowing you to create:

- Split levels and bi-levels
- Sunken living rooms and garages
- Cathedral and coffered ceilings.

In 3D views, you can adjust the default floor and ceiling height for the entire floor or the floor and ceiling height for an individual room. See “In 3D Views” on page 123.



All floor and ceiling heights are measured relative to zero, which is the default floor height for Floor 1. Unlike other default floor and ceiling heights, the default floor height for Floor 1 cannot be changed, but the floor heights of rooms on Floor 1 can be edited individually.

In order to raise or lower an area’s floor or ceiling height, you must give it a room definition. To create room definition without enclosing an area with solid walls, use

Railings .

Ceiling and floor heights are interrelated. Changing the floor height in one room can affect ceiling heights of the rooms below.

- If a room’s floor is lowered, its ceiling height is increased while the ceiling below that room drops.
- If the floor is raised, the ceiling height decreases while the ceiling below that room is raised.

If the rooms above a particular room have more than one floor height, the room’s ceiling is stepped.

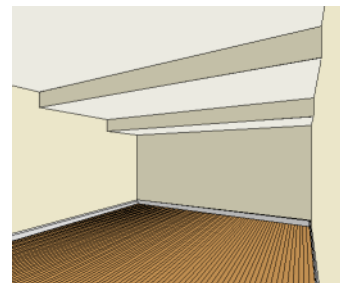

In a situation like this, a Lowered Ceiling can be used to cover “steps” made by different floor heights on the floor above. See “General Tab” on page 131.

To ensure that steps in floor and ceiling platforms have solid sides, define their room areas using Invisible Railings.

Split Levels

A split level can be created by raising or lowering the floor and ceiling heights of various areas of the plan.

In the following example, the lowest floor height is 0, the next is 24, and the next is 48 inches. The ceiling height in each room is set at 109 inches. See “Split Levels” on page 174.



Special Ceilings

By default, the program builds a flat ceiling platform on top the wall plates of a room. More varied and complex ceilings are made

using settings in the **Room Specification** dialog.

Lowered Ceilings

You can define a lowered or dropped ceiling in a room without affecting the top plate height of the walls by increasing the thickness of the Ceiling Finish.

In the following illustration, the default ceiling height for the entire first floor is 120", and the room on the right has a ceiling finish lowered to 96".

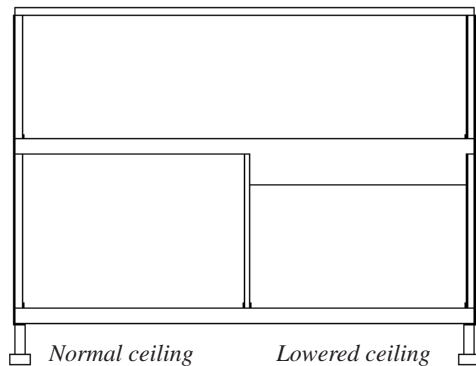

To create a lowered ceiling

1. Select the room in which you would like to specify a lowered ceiling.

- Click the **Open Object**  edit button to open the **Room Specification** dialog.
- On the Structure tab, increase the **Ceiling Finish** value by the amount that you would like to lower the ceiling.
- Notice that the preview diagram represents the Finished Ceiling height (F).

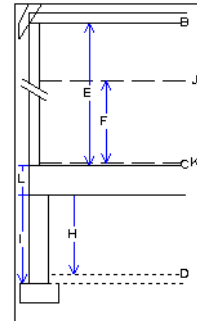

Cathedral Ceilings

A cathedral ceiling has the same pitch as the roof and is created using the underside of the roof above the room.

To create a cathedral ceiling

- Build a roof for your plan. See “Roofs” on page 190.

- Select the room and open the **Room Specification** dialog. See “Room Specification Dialog” on page 131.
- On the Structure tab, clear the check box for **Ceiling Over This Room**.

Tray Ceilings

A tray ceiling is flat in the center and sloped around the perimeter, and is easily created using the underside of roof planes above.

To create a tray ceiling

- In the **Room Specification** dialog, make sure that **Ceiling Over this Room** is checked, then specify the desired height of the walls as the **Ceiling Height**. See “Structure Tab” on page 132.
- Change the **Ceiling Height** of the room to the desired height of the flat ceiling surface in its center.

In floor plan view, dashed lines indicate where the ceiling changes from sloped to

flat. These lines are located on the “Ceiling Break Lines” layer in the **Display Options** dialog. See “Display Options Dialog” on page 60.

If the roof is rebuilt after the ceiling height is adjusted upward, the new roof will be raised to match the new ceiling height and a tray ceiling will not be created.

In the following example, a hip roof is built on 8’ (2400 mm) ceilings. After the roof is built, the Ceiling Height is raised to 10’ (3000 mm). The resulting ceiling follows the roof pitch for 2’ (600 mm), then becomes a flat ceiling.

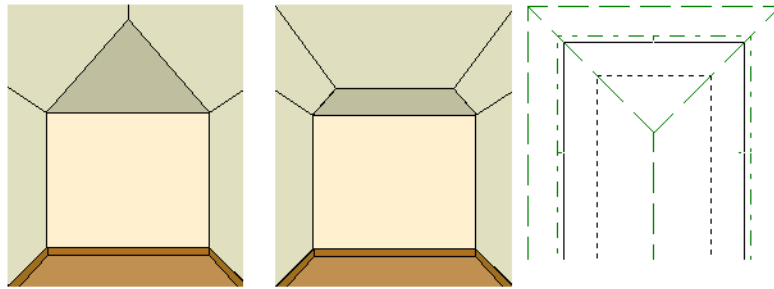

Hip roof with cathedral ceiling over.

Hip roof, ceiling over, ceiling height raised.

Ceiling Break lines in floor plan view.

Cantilever Undersides

Occasionally, a room will cantilever out past an exterior wall. You can specify the surface material of the underside of a cantilever on

the Materials tab of the **Room Specification** dialog. See “Room Specification Dialog” on page 131.

Room Specification Dialog



The **Room Specification** dialog controls the structural characteristics and appearance of a selected room. To open the **Room Specification** dialog, select a room and click the **Open Object** edit button. See “Selecting Rooms” on page 122.

Several of the tabs in the **Room Specification** dialog are also found in the **Floor** and **Room Defaults** dialogs. See “Floor and Room Defaults” on page 121.

Some values in this dialog are dynamic. A value with Default checked is referenced from the **Floor Defaults** dialog. To return a value to the default, replace the check mark. See “Dynamic Defaults” on page 48.

The settings in this dialog are similar to those in the **Floor Defaults** dialog, but affect only the selected room. See “Floor Defaults Dialog” on page 171.

General Tab

The General tab is not available in the **Room Defaults** dialog, and only two of the settings

here are active in the **Floor Defaults** dialog. See “Floor and Room Defaults” on page 121.

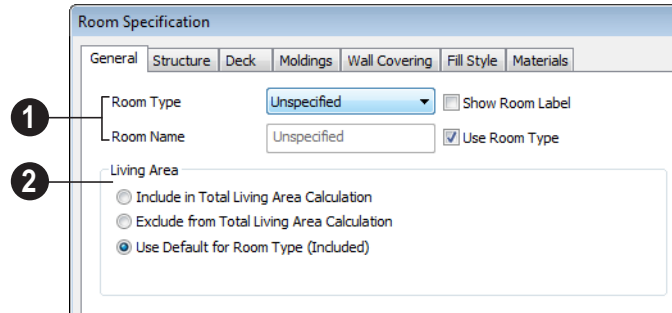

1 The settings here control the Room Type and the appearance of the Room Label.

- Select the **Room Type**. This affects some of the room’s characteristics. See “Room Types” on page 124.
- Check **Show Room Label** to display the room label in floor plan view. This option is unchecked automatically if you select “Unspecified” as the room type. See “Room Labels” on page 126.
- If you wish to use a custom name in the room label, uncheck **Use Room Type**, then specify the desired **Room Name** in the text field.

2 Specify whether the selected room is included in the **Living Area** calculation. See “Living Area” on page 127.

- Select **Include in Total Living Area Calculation** to include the room in the Living Area regardless of its Room Type.
- Select **Exclude from Total Living Area Calculation** to exclude the room in the Living Area regardless of its Room Type.
- Select **Use Default for Room Type (Included/Excluded)** to base the selected room’s inclusion in the Living Area on its Room Type.

Structure Tab

The Structure tab is also found in the **Floor** and **Room Defaults** dialogs and features a cross section diagram that shows the relationships between its various heights and platform thicknesses. It is meant to represent the relationships between heights and thicknesses rather than provide a scaled drawing of the model.

Two floors can be included in the diagram: the floor that the selected room is located on, and the floor below it, if one exists.

What appears in both the diagram and in the settings to its left may be affected by the location where you clicked to select the room. For example:

- If the selected room is located above two rooms with different structural settings, the position of the pointer relative to these two lower rooms determines which of them displays as the floor below.
- If the selected room is located below two rooms with different floor heights, its

absolute and relative ceiling height settings will be disabled.

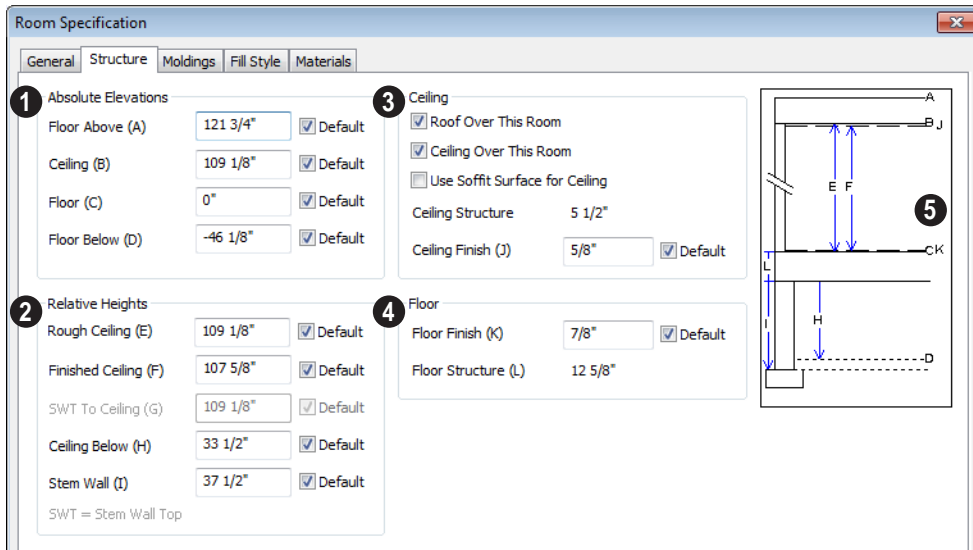

Check the **Default** box beside any height value to restore the default setting.

1 Absolute Elevations - These height values are measured from the default first floor height of zero. See “Floor & Ceiling Heights” on page 128.

- Specify the **Floor Above** height, which is the floor height of the room or rooms on the floor above the selected room. If multiple floor heights are specified directly above the selected room, this setting will be inactive and “No Change” will display.
- Specify the **Ceiling** height of the selected room. Not available in the **Floor Defaults** dialog on Floor 0, or if multiple floor heights are specified above the selected room.
- Specify the **Floor** height.

Note: The default floor height for Floor 1 is 0. It can be modified in the Room Specification dialog, but not in the Floor 1 Defaults dialog. See “Floor and Room Defaults” on page 121.

If a room is defined directly beneath the selected room on the floor below, additional settings may be available.

- Specify the **Floor Below** height, which is the floor height of the room directly below where you clicked to select the currently selected room.
- If the selected room is directly above a Garage and there is a foundation present, you can specify the **SWT Below** height, which is the top height of the concrete stem walls around the perimeter of the garage.

2 Relative Heights - These height values are measured from surfaces within the selected room or the room below.

- Specify the **Rough Ceiling** height, as measured from the subfloor surface to the bottom of the ceiling framing. Not available if multiple floor heights are specified directly above the selected room.
- Specify the **Finished Ceiling** height, as measured from the finished floor surface to the finished ceiling surface. Not available if multiple floor heights are specified directly above the selected room.
- Specify the distance from the **Stem Wall Top to Ceiling**. Only available when **Floor for this Room is Supplied by the Foundation 'Room' from the Floor Below** has been checked.
- Specify the **Ceiling Below** height, which is the height of the ceiling of the room below, as measured from that room's subfloor to rough ceiling surfaces. Not available when Auto Rebuild Foundation is enabled or if there is no room below the selected room. See "Rebuilding Foundations" on page 181.
- Specify the **Stem Wall** height, which is measured from the bottom of the room's floor framing to the top of the foundation wall footing and including a treated sill plate, if one is specified. Only available if

the selected room or the room below it is defined by foundation walls.

3 Specify the characteristics of the room's **Ceiling**.

- If **Roof Over This Room** is checked, a roof automatically generates over the room. If unchecked, no roof generates.
 - If **Ceiling Over This Room** is checked, the room has a flat ceiling. If unchecked, the ceiling follows the underside of the roof.
 - Check **Use Soffit Surface for Ceiling** to improve the 3D appearance of the transition between ceiling and eaves of exterior rooms with Ceiling Over This Room unchecked.
 - The thickness of the **Ceiling Structure** displays here for reference but cannot be changed.
 - Specify the thickness of the **Ceiling Finish** layer.
- 4** Specify the thickness of the **Floor Finish** layer.
- The thickness of the **Floor Structure** displays here for reference but cannot be changed.
- 5** A cross section diagram showing the relationship between the various height settings displays here for reference.

Moldings Tab

Chair rail, crown and base moldings can be assigned to a selected room on the Moldings tab. Moldings are placed around the wall surfaces of a room and continue around the surface of any soffit that is attached to the wall at the molding height.

The settings on this tab are also similar to those found in the **Floor Defaults** dialog, but affect only the selected room instead of all rooms on the current floor.

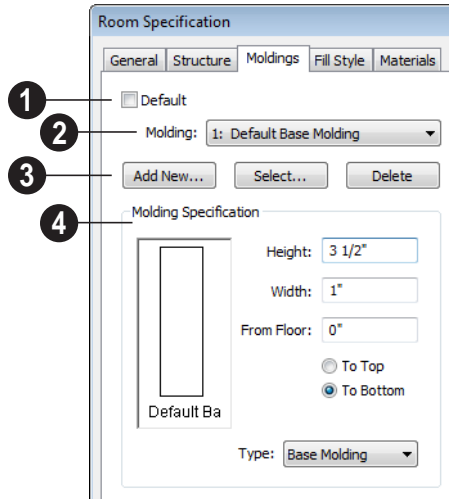

1 Uncheck **Default** to enable the settings that follow. When checked, the room uses the default moldings set in the **Floor Defaults** dialog. See “Floor Defaults Dialog” on page 171.

2 The **Molding** drop-down list includes all moldings currently applied to the selected room(s). Select one from the list to edit, replace, or delete it.

The Default Base Molding is a basic rectangular stock profile rather than a profile from the library.

3 Make changes to the moldings assigned to the selected room(s).

- Click the **Add New** button to open the **Select Library Object** dialog and select a new molding profile to apply to the room. See “Select Library Object Dialog” on page 295.
- Click the **Select** button to replace the currently selected molding with a different molding profile.

- Click the **Delete** button to remove the currently selected molding from the room.

4 **Molding Specification** - Make changes to the currently selected molding.

- Specify the **Height** and **Width** of the currently selected molding.
- Specify the distance of the selected molding **From Floor** and select whether this distance is measured **To Top** or **To Bottom** of the molding profile.
- Select the currently selected molding’s **Type** from the drop-down list: crown, chair rail, or base molding.

Fill Style Tab

The settings on this tab affect the appearance of the room in floor plan view. This tab is also found in the **Floor Defaults** dialog. For more information, see “Fill Style Tab” on page 225.

Materials Tab

The settings on this tab affect the appearance of a selected room's walls, floor, ceiling and moldings in 3D views. See "Materials Tab" on page 303.

Default molding and ceiling and floor covering materials can be set in the **Floor Defaults** dialogs.

Doors

Home Designer Essentials comes with tools for creating a wide variety of interior and exterior doors. In addition, the library offers a large selection of specialty doors and doorways including hinged, sliding, pocket, bifold, and garage doors.

Chapter Contents

- Door Defaults
- The Door Tools
- Displaying Doors
- Editing Doors
- Changing Door Swings
- Special Doors
- Door Specification Dialog

Door Defaults



Default Settings are accessed by selecting **Edit> Default Settings**.

Click the “+” next to **Doors** to show the door sub-headings. Select a subheading and click the **Edit** button to open the defaults dialog associated with your selection:

The values in the **Door Defaults** dialog are initial values for interior or exterior doors. Individual doors can be edited after they are created.

The **Door Defaults** dialogs look nearly the same as the **Door Specification** dialog. See

“Door Specification Dialog” on page 147.

There are only a couple of differences:

- Since default settings are specified here, “Use Default” is not an option for some settings as it is in the **Door Specification** dialog.
- The **Door Type** cannot be changed in the Defaults dialogs.

The Door Tools



To place a door, select the type you want from the **Build> Door** submenu.

With a Door Tool active, move your mouse pointer over a wall section. If there is room enough along the wall to fit a 12" (300 mm) wide door, a preview of the door will display. When a preview can be seen, click on a wall to place a door in the wall at that location.

Hinged and Sliding Doors have both Interior and Exterior Door Defaults. If the wall is an exterior wall or one that separates an interior from an exterior room, the program places an exterior door based on the default settings for exterior doors. If the wall is an interior wall, the program places an interior door based on the default settings for interior doors. This rule applies to doors copied and pasted from one location to another just as it does to newly placed doors. See "Door Defaults" on page 138.

Once placed, any door may be changed into any other type of door using the **Door Specification** dialog. See "Door Specification Dialog" on page 147.

Hinged Doors



Select **Build> Door> Hinged Door** and click a wall where you want to place a hinged door. Hinged doors can be placed on interior or exterior walls, and can be set up so that different door styles are placed in each. A hinged door becomes a double door when its width is four feet or greater.

The initial swing direction of a hinged door depends on the location of the mouse pointer

relative to the wall when you click. The door will swing towards the side of the wall that you click nearest.

The initial hinge side of a hinged door can be set by clicking to place the door and then holding the mouse button down rather than releasing it. Move the mouse toward the end of the door that you would like the hinges to be on: as the mouse pointer nears either end, the door preview's hinge side will move to that end. You can also adjust the door's swing direction in this manner. When the swing direction and hinge side are correct, release the mouse button.

Doorways



Choose **Build> Door> Doorway** and click a wall to place a doorway (an opening without a door). Doorways can be placed on interior or exterior walls, or in railings and fences to provide an opening. You can assign a door from the library to a doorway.

Sliding Doors



Select **Build> Door> Sliding Door** and click a wall where you want to place a sliding door. Sliding doors can be placed on interior or exterior walls and can be set up so that different door styles are placed in each. If placed in an exterior wall, the door is glass; if placed in an interior wall, it is a solid slab.

The initial opening side of a sliding door can be specified by moving the mouse pointer along the wall while the mouse button is still pressed.

The default sliding door dimensions are 5'-0" x 6'-8" with a 12" bottom frame and a 6" frame on the sides and top.

Pocket Doors

 Select **Build> Door> Pocket Door** and click a wall where you want to place a pocket door.

As with sliding doors, the initial opening side of a pocket door can be specified by moving the mouse pointer along the wall while the mouse button is still pressed.

The default pocket door dimensions are 2'-6" x 6'-8" high. A pocket door becomes a double pocket door if its width is four feet or greater.

Bifold Doors

 Choose **Build> Door> Bifold Door** and click a wall where you want to place a bifold door.

Like a hinged door, the initial opening side of a bifold door depends on the location of the mouse pointer relative to the wall when you click. The door will open towards the side of the wall that you click nearest.

Similarly, the initial hinge side of a sliding door can be specified by moving the mouse pointer along the wall while the mouse button is still pressed.

The default interior single bifold door is 2'-6" x 6'-8". A bifold door becomes a double bifold if its width is greater than three feet.

Bifold doors always display closed in all 3D views.

Garage Doors

 Choose **Build> Door> Garage Door** and click a wall to place a garage door.

The default garage door is 8'-0" x 7'-0" high. A garage door must be at least two feet wide.

In floor plan view, dashed lines show the size and location of the garage door when open.

Garage doors will build into a garage stem wall provided the room is designated as a garage before the door is inserted. See "Room Types" on page 124.

The Doors & Doorways Library

 The Doors & Doorways library can be accessed by selecting **Library> Library Browser** and browsing to Home Designer Content> Architectural. This library folder contains a variety of interior and exterior doors, as well as special entryways and wrapped openings.

Entryways and wrapped openings are examples of Doorways, which are wall openings that do not have doors within them.



To add a door to the Doorway, select a **Door Type** other than "Doorway" from the drop-down list in the **Door Specification** dialog. See "General Tab" on page 148.

You can also select a custom door from the library and place it into a doorway in floor plan view or any 3D view.

To place a library door in a doorway

1. Go to floor plan view or any 3D view.
2. Open the Library Browser.

3. Navigate through the Doors library category until you find the custom door style desired.
4. Select the door in the Library Browser, then click on the doorway to place the selected door within it. If a door already exists, it is replaced.
5. Continue clicking other doorways until all changes have been made.

Displaying Doors



The display of doors, door labels, and opening indicators is controlled in the **Display Options** dialog. See “Display Options Dialog” on page 60.

Doors can only be placed in walls, so if a wall’s layer is turned off, any doors placed in that wall will not display, either. See “Displaying Walls” on page 105.

If the “Doors” layer is turned off, doors and their casing do not display but openings in the walls where they are located are visible.

In Floor Plan View

When the “Doors” layer is turned on in floor plan view, door symbols represent the width of the opening and indicate its swing. If a door is recessed, the affected wall layers will adjust to accommodate the casing.

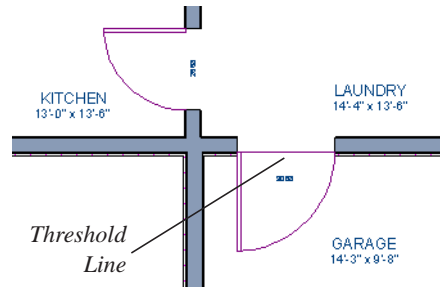

Doors in exterior walls and doors that open to exterior type rooms such as a Garage, Porch, or Deck have a threshold line across the opening in floor plan view. See “Room Types” on page 124.



If an exterior door to a Garage room on Floor 1 extends into a Garage stem wall or curb on Floor 0, its location will be indicated on Floor 0. See “Garages” on page 182.

In 3D Views

You can specify whether a selected door is shown open or closed in 3D views by

clicking the **Show Door Open in 3D**  and **Show Door Closed in 3D**  edit buttons as well as in the **Door Specification** dialog. See “General Tab” on page 148.



If a door is set to display open in 3D, the angle of the open door can be changed using the edit handles. See “Using the Mouse” on page 142.

Door Labels

Door labels display in floor plan view, centered on the doors they represent, when the “Doors, Labels” layer is turned on. Door labels indicate Width and Height. For example:

- In Imperial plans, the label for a 3’-0” wide, 6’-8” high double hung window will read 3068.
- In metric plans, the label for a 900 mm wide, 2100 mm high double hung window will read 900x2100.

Editing Doors

Before a door can be edited, it must be selected. To select a door, click it when the **Select Objects**  tool or any of the **Door Tools**  are active. Doors and/or windows can also be group selected and edited. See “Selecting Objects” on page 71.

Blocked units are made up of individual doors and windows that have been grouped together to act as one object. You can create what is essentially a blocked door unit by assigning a library door to a doorway from the library

Select a blocked unit by clicking on it in any view. To select a door that is a component of a blocked unit, click at the location of the component in question, then click the **Select Next Object**  edit button. See “Selecting Objects” on page 71.

In the Specification Dialog

 The most precise method of editing a door is to use the **Door Specification** dialog. Door type, size, casing, materials, and more can all be specified in this dialog. See “Door Specification Dialog” on page 147.

Using the Mouse

In floor plan view, click either of the two end handles and drag along the wall to change the width. The label showing the size updates as the handles are dragged. Click and drag the Move handle at the center to move the door along the wall it is placed in. Use the triangular Rotate handle to adjust the door’s swing. If the door’s label displays, an additional handle is available to move the label.

In 3D views, a selected door has five edit handles: the Move handle at the center and a Resize handle on each edge. Click and drag an edge handle to resize the door.



A door or window moved against an intersecting wall temporarily stops when the casing meets the intersecting wall. You can continue to drag and it resumes movement past the intersecting wall.

Using the Edit Tools

A selected door or doors can be edited in a variety of ways using the buttons on the edit toolbar. See “The Edit Toolbar” on page 21.

- Click the **Change Opening/Hinge Side**  edit button to change the side of the

door that its hinges are on. See “Changing Door Swings” on page 143.

- Click the **Show Door Open in 3D**  or **Show Door Closed in 3D**  edit button to control the selected door’s appearance in 3D views. See “In 3D Views” on page 141.
- Click the **Gable Over Door/Window**  to create a gable over the selected door(s) the next time the roof is rebuilt. See “Gable Over Door/Window” on page 194.

Centering Doors



The **Center Object** edit button allows you to center a selected door along a

wall within a room or relative to a cabinet or window. See “Using Center Object” on page 90.

To center a door along a wall

1. Select a door or combination of windows and doors in floor plan view.
2. Click the **Center Object**  edit button then choose from one of the following options:
 - Click near a wall inside a room to center the door along that wall in that room.
 - Click outside the house (on the exterior room) near an exterior wall to center the door along an exterior wall.

Changing Door Swings



Door swing direction and hinge side can be changed using the **Change Opening/Hinge Side** and **Change Swing Side** edit buttons.

The **Change Opening/Hinge Side**  edit button is available for all doors except double doors and garage doors.

The **Change Swing Side**  edit button is available for all doors except pocket doors.

Hinged Doors

In addition to using the edit buttons, hinged doors’ hinge side and swing direction can be changed using the triangular Rotate edit handle.

To adjust the angle of swing:

1. In floor plan view, select the door and grab the triangular handle.
2. Drag to change the amount of swing.

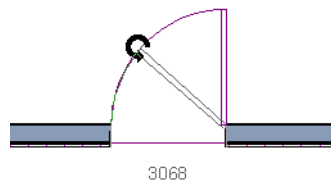

3. Release the mouse.

If you drag near the closed position, the door snaps to a closed position.

To change the swing using edit handles:

1. In floor plan view, select the door and grab the triangular edit handle.

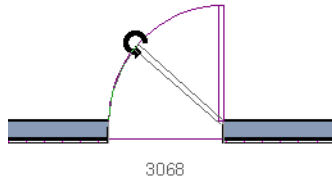

2. Drag the pointer along the path of the new arc to change the hinge side and/or swing direction.

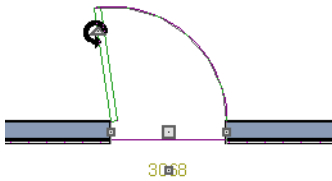

3. Release the mouse.

To change the swing using edit buttons:

1. In floor plan view, select the door.
2. To change the hinge side, click the **Change Opening/Hinge Side**  edit button.

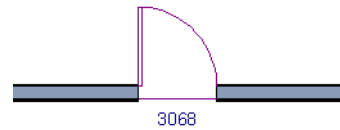
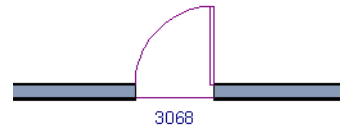

3. To change the swing direction, click the **Change Swing Side**  edit button.

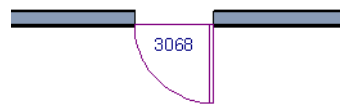
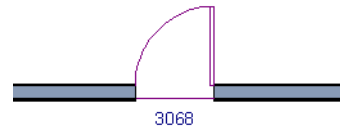

Sliding Doors

To change the side of a sliding door that is fixed, select the sliding door then click the

Change Opening/Hinge Side  edit button.



To flip the fixed and moving sides of the door, click the **Change Swing Side**  edit button.



As with hinged doors, you can also change the Opening/Hinge and Swing sides of a sliding door by clicking and dragging the triangular edit handle.

Pocket Doors

To change the direction of a pocket door, select it and click the **Change Opening/Hinge Side**  edit button.



Note: There must be enough room for the entire door to fit in the opposite wall or the door does not change.

As with hinged doors, you can also change the Opening/Hinge side of a pocket door by clicking and dragging the triangular edit handle.

Bifold Doors

To change the side of a bifold door that is fixed, select it then click the **Change Opening/Hinge Side**  edit button.



To change the hinged side of the door, click the **Change Swing Side**  edit button.



As with hinged doors, you can also change the Opening/Hinge and Swing sides of a bifold door by clicking and dragging the triangular edit handle.

Garage Doors

To change the side of a garage door that it faces, select it and click the **Change Swing Side**  edit button.

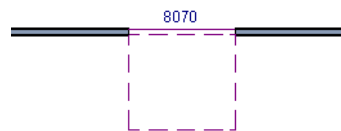

As with other door types, you can also change the Swing side of a bifold door by

clicking and dragging the triangular edit handle.

Special Doors

A variety of special doors and doorways can be created in Home Designer Essentials.

Wrapped Openings

You can create a wrapped opening by placing a doorway in the wall and checking **Suppress Casing** in the **Door Specification** dialog. See “Casing Tab” on page 149. If base molding is present, it will wrap around the opening.



Openings in Railings

Use the **Doorway**  tool to open a railing for a stairway or other access.

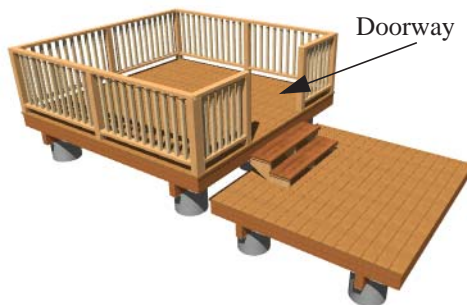

To open a railing across an entire section, resize the doorway’s **Width** so that it is greater than the length of the railing in the **Door Specification** dialog. The opening resizes to the maximum width possible for that space. See “General Tab” on page 148.

To add a gate, specify the doorway’s **Door Type** as a Door, then choose an appropriate gate as the **Door Style**. A selection of gates is available in the Fences & Railings library folder. See “Placing Library Objects” on page 293.

Transoms Above Doors



Transom windows above doors are created the same as other stacked windows. See “Grouped Windows” on page 157.

Creating a Doorway with a Railing

When a railing is specified as **No Room Def**, it can be positioned within a **Doorway** .



To create a doorway with railing

1. Place a **Doorway**  at the desired location in your plan.
2. Select **Build > Wall > Straight Railing** , then click and drag to draw a railing parallel to the wall with the doorway.
3. Click on the railing, then use the Resize edit handles to adjust the length of the railing as needed. See “Using the Edit Handles” on page 73.
4. With the railing selected, click the **Open Object**  edit button.
5. On the General tab of the **Railing Specification** dialog, check **No Room Def** and click OK. See “General Tab” on page 114.
6. With the railing still selected, Ctrl + drag it into position within the doorway. See “To move an object freely” on page 89.

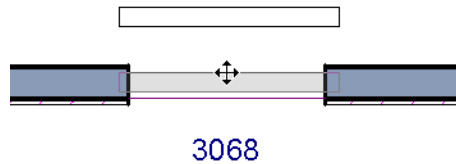

Positioning a railing in a doorway

Placing a Gable Over a Door

 Click the **Gable Over Door/Window** edit button to produce a gable roof over the selected door(s) the next time automatic roofs are built. See “Gable Over Door/Window” on page 194.

You can manually edit or delete this gable line at any time. Your changes take effect when the automatic roofs are rebuilt. This can also be used with group selected doors.

Door Specification Dialog

 To open the **Door Specification** dialog, select a door and click the **Open Object** edit button or double-click on

a door using the **Select Objects**  or a **Door**  tool.

General Tab

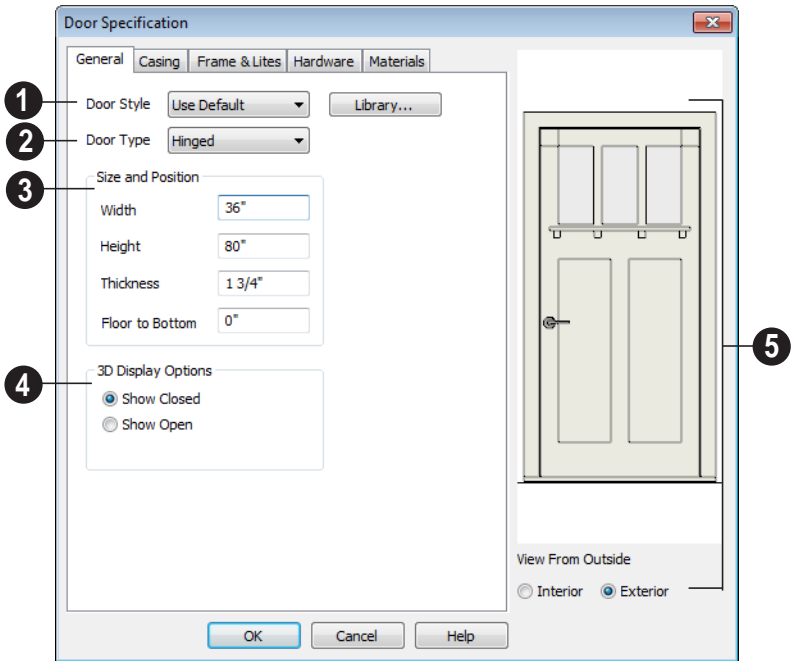

- 1 Door Style** - Define the door as slab, glass, panel, or louvered, or select a door style from the library. Choose “Use Default” to use the default door style set in the **Door Defaults** dialog. See “Door Defaults” on page 138.
- Select “Library” from the list or click the **Library** button to choose a door symbol from the library. Once a library door is selected, that door is added to the Door Style list. See “Select Library Object Dialog” on page 295.
- 2 Door Type** - Specify doorway, hinged, slider, pocket, bifold, or garage door.
Slider, pocket, bifold and garage are not allowed as Exterior Door Defaults.

- 3 Specify the Size and Position** of the selected door.
 - Specify the **Width, Height, and Thickness** of the door.
 - **Floor to Bottom** - Specify the height of the bottom of the door frame as measured from the subfloor.
- 4 3D Display Options** - Specify whether the selected door is drawn closed or open in 3D views.
- 5 A preview of the door displays** on the right side of the dialog box.
 - Select **Interior** or **Exterior** to specify which side of the door displays in the preview.

Casing Tab

Changes made on the Casing tab can only be seen in 3D views.

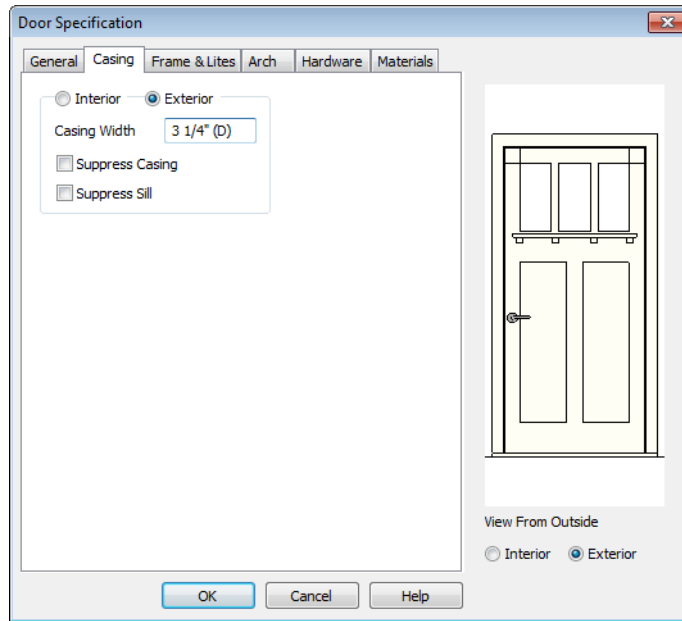

Specify the casing for the selected door.

- Select the **Interior** or **Exterior** radio button to define the casing for that door side and display it in the preview image. This choice is not available for interior doors, which use the same values for both sides.
- Define the **Width** of the selected casing.
- Check **Suppress Casing** to have a wrapped opening instead of casing.
- Check **Suppress Sill** to prevent a sill from being generated under the door.

Frame & Lites Tab

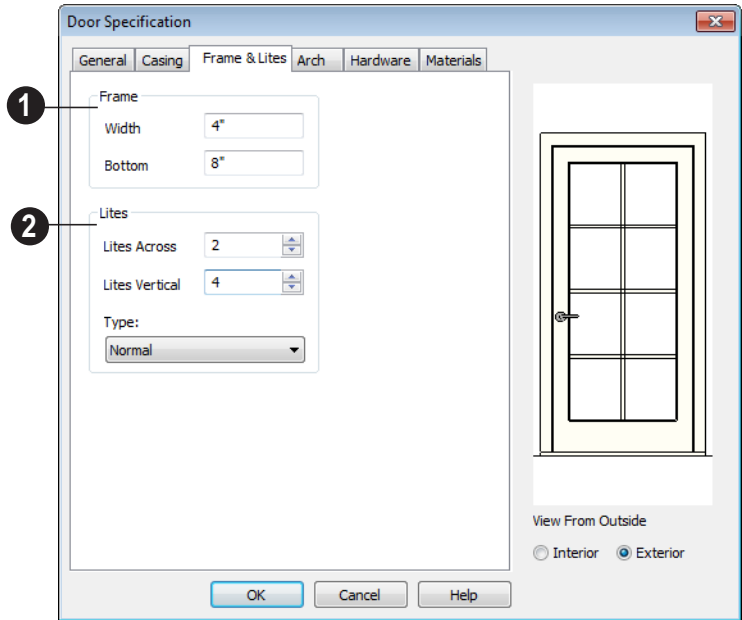

1 **Frame** - Specify the dimensions of the door's rails and stiles. Only available for Glass, Panel, and Louvered Doors. See General Tab.

- Specify the **Width** of the stiles and top rail.
- Specify the height of the **Bottom** rail.

2 Specify the number of **Lites**, or panes of glass, as well as their configuration. Only available for Glass doors.

- Specify the number of horizontal **Lites Across**.
- Specify the number of **Lites Vertical**.
- Choose a **Type**, or style, from the drop-down list.

- **Normal** style is the most common, with vertical and horizontal muntin bars.
- **Diamond** style uses angled muntins to divide the lites.
- **Prairie** style is based on the normal style, but with all the central muntins removed, leaving only the two outside muntins, both horizontally and vertically. Lites Across and Vertical are typically set between 6 and 8.
- **Craftsman** style is based on the normal style, but only the topmost horizontal muntin is kept with all the portions of the vertical muntins above it. Lites Across and Vertical are typically set between 4 and 8.

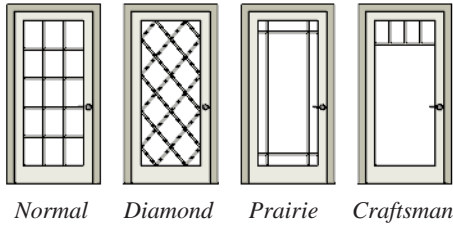

Hardware Tab

Many of the settings on the Hardware tab are Dynamic Defaults: if “Use Default” is selected, the setting in the **Door Defaults**

dialog is used. See “Dynamic Defaults” on page 48.

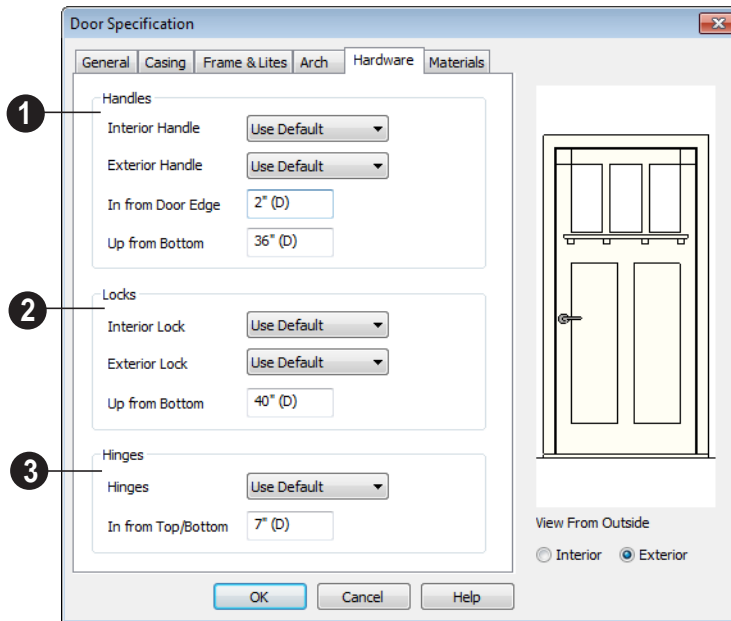

- 1 Specify the **Handles** to be used on the selected door.
- Select an **Interior Handle** and/or **Exterior Handle** from the drop-down lists.
- Specify the location of the door handles **In From Door Edge**.

- Specify the location of the door handles **Up From Bottom**.
- 2 Specify the door’s interior and exterior **Locks**.
- Select an **Interior Lock** and/or **Exterior Lock** from the drop-down lists.

- Specify the location of the door locks **Up From Bottom**. The locks use the same In From Door Edge value as the handles.
- ③ Specify the **Hinges** to be used on the door. Two hinges are placed for interior doors, and three for exterior doors.
- Select a style of **Hinges** from the drop-down list.
- Specify the distance **In From Top/Bottom** of the door to the center of the top and bottom hinges.

Note: For hinges to look right, it is best to have at least a 1/4" (6 mm) reveal for the interior, or hinge side, door casing.

Materials Tab

The Materials tab is available for numerous objects. For more information, see “Materials Tab” on page 303.

Windows

Home Designer Essentials can model a wide variety of windows. Fixed glass, hung, casement, sliding, awning, hopper, and louver window styles can all be created with the standard Window tool, and even set as the default. Home Designer Essentials can create bay, box, and bow windows at the click of a button. In addition, the library contains many mullied window combinations.

Chapter Contents

- Window Defaults
- The Window Tools
- Special Windows
- Grouped Windows
- Displaying Windows
- Editing Windows
- Bay, Box, and Bow Windows
- Bay, Box, Bow Windows & Roofs
- Window Specification Dialog
- Bay/Box/Bow Window Specification Dialog

Window Defaults



Default Settings can be accessed by selecting **Edit> Default Settings**. Select Window from the **Default Settings** dialog.

The settings in the **Window Defaults** dialog control the attributes of a window when it is initially placed in a plan, so you should define the type of window that will be placed most often in your model. See “Default Settings vs Preferences” on page 47.

The tabs in the **Window Defaults** dialog are similar to those found in the **Window**

Specification dialog. For more information, see “Window Specification Dialog” on page 164.

Dynamic Window Defaults

A variety of window default values are dynamic, including the **Window Type**, **Casing Specifications**, and **Sash** sizes. All **Materials** are also dynamic. When a dynamic default is changed, existing windows using the default value are affected. See “Dynamic Defaults” on page 48.

The Window Tools



To place a window, select **Build> Window** and choose the desired window type. Click on a wall to place a window of the selected type at that location. Bay, box and bow windows can only be placed in straight walls, while standard windows can be placed in both straight and curved walls.

Standard Windows



Select **Build> Window> Window**, then click on a straight or curved wall to place a standard window at that location.

A standard window is a single window that is not a bay, box, or bow window. These special types are made up of multiple standard windows.

A standard window that is part of a special window is called a component window.

Standard windows can be specified as any of a variety of window types, such as double hung, casement and awning. See “Window Specification Dialog” on page 164.

Bay Windows



The roof is affected by Bay, Box and Bow Windows. These windows should therefore be placed before the roof is built.



A **Bay Window** is composed of three wall sections, each with a single component window. The two side walls are at an angle to the main wall. Select **Build> Window> Bay Window** and click on a straight wall to produce a bay window.

When initially placed, bay windows measure 2’-2” across at the front, 4’-2” across at the back, and are 1’-0” deep. The component windows are specified in the **Window**

Defaults dialog and their sizes adjust to fit the available space.

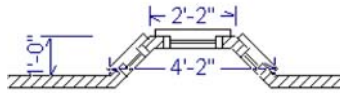

Box Windows



A **Box Window** is a bay window with side angles set at 90°. Select **Build> Window> Box Window** and click on a straight wall to produce a box window.

Box windows initially measure 4'-2" wide with a depth of 1'-6". The component windows are specified in the **Window Defaults** dialog and their sizes adjust to fit the available space.

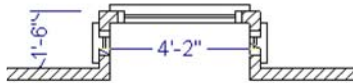

Bow Windows



A **Bow Window** is a group of identical wall segments that form a segmented curve. Select **Build> Window>**

Bow Window and click on a straight wall to produce a 5-section bow window.

The component windows are specified in the **Window Defaults** dialog. Their sizes adjust to fit the available space.

The 5-section bow below has a 4'-10" radius centered 3'-9" inside the wall, giving an opening 5'-10" across and a depth of 11½".

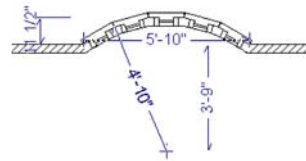

Note: Bay, box, and bow window areas are not included in the living area or in room standard area calculations. They are included in room interior area calculations.

Windows Library



Select **Library> Library Browser**, then browse to Home Designer Core Catalogs> Architectural to access a selection of special windows. Select the desired window, then click on a wall to place the window at that location.

Special Windows

A variety of special windows can be created using multiple standard windows, the edit tools or custom symbols.

Creating Manual Bay, Box and Bow Windows

Sometimes it is easier to draw bay, box and bow windows manually than to use the

automatic tools. Bays created using walls can have more than one window per section, which is not possible using a bay window unit.

Bear in mind that moving a manually created bay, box or bow window is generally more difficult than moving a unit created with one

of the **Window Tools**  since it is composed of individual walls.

Corner Windows

Corner windows are produced when each window has one edge at or past the interior side of the adjacent wall.



To create a corner window, first create the desired window on each side of the corner. The header height and the sill height of both windows must be the same.



To move a window all the way into a corner, check Ignore Casing for Opening Resize in the Plan Defaults dialog. See “General Plan Defaults Dialog” on page 48.

Once the corner window is formed, its components and corner post size can be

adjusted. Blocked units can also meet at a corner this way.

Special Window Shapes

A selection of special shaped windows is available in the Windows Library, including arched windows and mulled units.

Placing a Gable Over a Window



Click the **Gable Over Door/Window** edit button to produce a gable roof over the selected window(s) the next time automatic roofs are built. See “Gable Over Door/Window” on page 194.

You can manually edit or delete this gable line at any time. Your changes take effect when the automatic roofs are rebuilt. This tool can also be used with group selected windows.

Vents

A selection of attic, foundation and gable vents are available in the Library Browser. See “The Library” on page 282.

Vents are placed in the same manner as regular windows and can be edited in much the same way, as well.

Grouped Windows

Windows can be grouped together to create a wide variety of custom configurations. Stacked windows are easy to create in 3D

views, particularly Elevation views, using their edit handles. See “Editing Windows” on page 160.



Notice how the windows and door in this example are separate, with spaces between them. Doors and/or windows can also be organized into a unit in which there are no spaces between the windows and door units, and the casing between them is shared.

Automatically Mullered Openings

To form a mullered group of windows and/or doors, move them close enough together so that their casings touch. Once the casings touch, the windows are mullered together with one casing between the two of them.

The sill of each window in the group must be at the same level for them to share the middle casing. The casing tops do not have to be at the same level. The casings are modeled as if they are one unit but the windows remain separate objects for dimensioning and the Materials List.

Windows can be automatically mullered to doors if the bottom of the window is at the elevation of the floor, equal to the bottom of the door.

Mullered Units in the Library

A selection of mullered window units is available in the Windows library. To place

one in your plan, select it and click on a wall in any view. See “Placing Library Objects” on page 293.

Selecting Components of Mullered Units

To select a component of a mullered unit from the library, click at the location of the component in question, then click the **Select**

Next Object  edit button or press the Tab key until that individual component is selected. Only the component clicked on is selectable using this method. If you need to select a different component, click on it and repeat the process.

If there are multiple levels, it is easiest to select the components in a 3D view. When you have selected an individual component, you can change its parameters in the **Window Specification** dialog. See “Window Specification Dialog” on page 164.

If the selected component is not itself a mullered unit and has no components above it, its **Height** and **Arch** parameters can be changed. Changing the Height causes the component top to move. The bottom remains stationary.

Displaying Mullered Units



As with other windows, the display of mullered window units is controlled in the **Display Options** dialog. See “Displaying Objects” on page 59.

Mullered units are placed on the “Windows” layer by default and have a single label, which is on the “Windows, Labels” layer. Mullered units from the library are also included in the windows category of the

Materials List. If the component objects of a mullered unit have unique moldings or

materials, they will not be noted in the Materials List.

Displaying Windows



The display of windows in floor plan and 3D views can be controlled in the **Display Options** dialog. See “Display Options Dialog” on page 60.

Windows can only be placed in walls, so if a wall’s layer is turned off, any windows placed in that wall will not display, either. See “Displaying Walls” on page 105.

If the “Windows” layer is not set to display, window casing and other components are not visible, but the openings in the walls where they are located can still be seen.

In Floor Plan View

A window’s frame, glass, and sill are all represented in floor plan view. This makes some window types, notably Sliding and Double and Triple Casement windows, distinguishable.



Double Hung

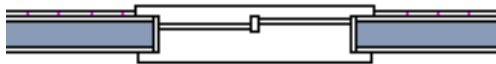

Left Sliding

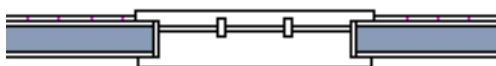

Triple Casement

Window types in floor plan view

Bay, box, and bow windows have dimensions lines associated with them.

- You can suppress their display by turning off the “Manual Dimensions” layer or on a unit by unit basis in the unit’s specification dialog. See “Bay/Box/Bow Window Specification Dialog” on page 169.
- The arrow style and fill are set in the **Dimension Defaults** dialog. See “Dimension Defaults Dialog” on page 342.

Window Labels

Window labels display in floor plan view, centered on the windows they represent, when the “Windows, Labels” layer is turned on. Window labels indicate Width and Height, followed by Type. For example:

- In Imperial plans, the label for a 3’-0” wide, 4’-0” high double hung window will read 3040 DH.
- In metric plans, the label for a 900 mm wide, 1200 mm high double hung window will read 900x1200 DH.

Editing Windows

Before a window can be edited, it must be selected. Click on a window when the **Select**

Objects  tool or any of the **Window**

Tools  are active. Doors and/or windows can also be group-selected and edited. See “Selecting Objects” on page 71.

To select a window that is part of a blocked unit, click the component window, then click the **Select Next Object**  edit button. See “Selecting Components of Mulled Units” on page 158.

Windows can be edited using their edit handles, the edit toolbar buttons, and the **Window Specification** dialog. See “Window Specification Dialog” on page 164.

When you select a window in floor plan view, the window size label displays the width followed by the height. For example, a 3036 window is 3’-0” wide by 3’-6” high.

In the Specification Dialog



The most precise method of editing a window is to use the **Window Specification** dialog. The window type, size, casing, materials, and more can all be specified in this dialog. See “Window Specification Dialog” on page 164.

Using the Mouse

- In floor plan view, click either of the two end handles and drag along the wall to change the width. The label showing the size updates as the window is resized.
- In 3D views, a selected window has five edit handles: the Move handle at the cen-

ter and a Resize handle on each edge. Click and drag an edge handle to resize the window.

Note: Using the edit handles is the only way to resize bay, box and bow window systems.

- A single window or a group of windows can be moved with the center edit handle.
- A door or window moved against an intersecting wall temporarily stops when it is the casing distance from the intersecting wall. You can continue to drag and it resumes movement past or onto the intersecting wall. Enable **Ignore Casing for Opening Resize** in the **Plan Defaults** dialog to turn off this behavior. See “General Plan Defaults Dialog” on page 48.

Using the Edit Tools

A selected window or windows can be edited in a variety of ways using the buttons on the edit toolbar. See “The Edit Toolbar” on page 21.

- Click the **Gable Over Door/Window**  to create a gable over the selected window(s) the next time the roof is rebuilt. See “Gable Over Door/Window” on page 194.

Bay, Box, and Bow Windows



Bay, Box and Bow Windows are created much the way regular windows are: select a tool, then click a wall to place that window type.

Home Designer Essentials automatically builds a foundation under bay/box/bow windows placed on floor 1 unless they are raised from their original position. That section of the foundation wall is also a bay/box/bow, but without windows. If the foundation was generated before the window is placed, the foundation must be rebuilt or edited manually.

Editing Bay, Box and Bow Windows

Bay, box and bow windows are edited similar to regular windows, with one exception: in floor plan view, a diamond-shaped Depth edit handle displays on the section. Drag this Depth handle outward to increase the depth, or inward to decrease the depth of the unit. See “Editing Windows” on page 160.

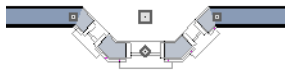

Depth edit handle on a bay window

Bay, box and bow windows can also be edited in their respective specification dialogs. See “Bay/Box/Bow Window Specification Dialog” on page 169.

Displaying Bay, Box and Bow Windows

The display of bay, box and bow windows is controlled in the **Display Options** dialog. See “Display Options Dialog” on page 60.

Like other windows, bay, box and bow windows can display labels. See “Window Labels” on page 159.

Bay, box and bow window width and radius dimensions, which display in floor plan view, are placed on the “Dimensions, Manual” layer. See “Displaying Objects” on page 59.

Component Windows

A component window within a bay, box or bow window can be resized like any other standard window. To select a component window, click at the location of the component in question, then click the **Select Next Object**  edit button or press the Tab key.

- Only the bay or box window component that was clicked on is selected using this method. If you need to select a different component, click on it and repeat the process.
- In a bow window, all components are identical, so only one component can be selected. Changing this component changes them all.

Resizing Components

An individual component window can be resized using the edit handles, by changing

settings in the component's **Window Specification** dialog.

When a bay/box/bow window is first created, there is room for one standard trimmer on each side of each component window. When the bay as a whole is moved and resized, its components automatically resize so that a standard trimmer is still accommodated.

If a component window is resized, it retains its size if at all possible when the containing bay/box/bow window is moved or resized. If the bay is resized in such a way that the component is too large to fit even with a thinner trimmer, the component resumes its default behavior, resizing as the containing bay window is resized.

Floors and Ceilings

When originally created, the floor and ceiling within a bay, box, or bow window are the same heights as the floor and ceiling of the room in which it is placed.



Both the top and bottom heights of these window units can be adjusted in a 3D view using the window's edit handles to create a lowered ceiling and/or a bench seat or garden window.



When the ceiling is lowered, the top heights of the walls that define the window unit are also lowered. When a roof is built over the unit, its height will be affected, as well.

When the bottom of the window is raised to create a bench seat, the unit's walls will not reach the ground. As a result, window units with bench seats will have no foundation beneath them when the foundation is built.

Bay, Box, Bow Windows & Roofs

Several different roof styles can be specified for bay, box and bow window units in the

Bay/Box/Bow Specification dialog. See “Bay/Box/Bow Window Specification Dialog” on page 169.

If you change a bay, box, or bow window’s roof specification, you will need to rebuild the roofs to see the changes. See “Rebuilding Roofs” on page 192.

Hip Roofs

By default, a hip roof is built above the unit when roofs are automatically generated. No roof directives need to be selected in the specification dialog to produce this roof.



Use the Existing Roof

To generate a standard roof that ignores a bay, box, or bow window, check **Use Existing Roof**.

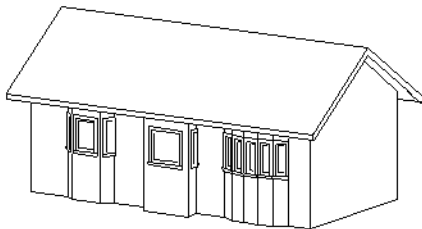

With this option the bay, box, or bow windows is tucked under the roof eave. You may find it helpful to increase the width of the eaves. See “Roof Tab” on page 193.

Extend the Existing Roof

To have the main roof extend down over the window unit and follow the shape of the unit, select **Extend Existing Roof**.

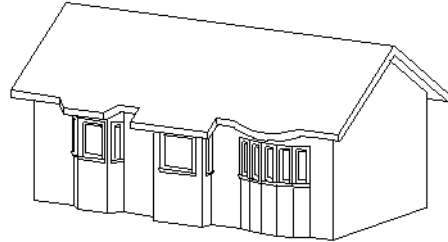

For this roof style, the ceiling heights of the window unit and the adjacent room must be the same. If you lower the ceiling of the window unit and then build the roof, a lower hip roof over the window is created. See “Floors and Ceilings” on page 162.

If a header is desired over the window unit, first build the roof, then lower the ceiling of the window unit. Do not rebuild roof planes.

Rectangular Hip Roofs

To create a rectangular-shaped hip roof above a bay, box, or bow window, select **Rectangular Roof Over**.

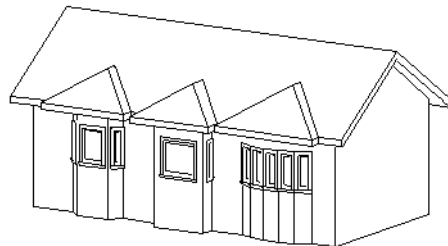

Extend Existing Roof - Rectangular

To extend the main roof down over a window unit to create a rectangular roof over it rather than one that follows its shape, select both **Extend Existing Roof over** and **Rectangular Roof Over**.

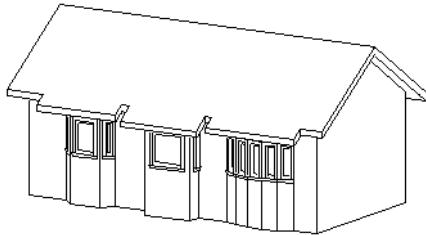

Gable Roof



A gable roof is not one of the automatic options for the roof above a bay, box or bow window.



To create a gable roof over a normal window, use the Gable Over Door/Window edit button. See “Gable Over Door/Window” on page 194.

Window Specification Dialog



To open the **Window Specification** dialog, select a window and click the **Open Object** edit button or double-click the window using the **Select Objects**  or a **Window**  tool.

The settings in this dialog are similar to those in the **Window Defaults** dialog. See “Window Defaults” on page 155.

General Tab

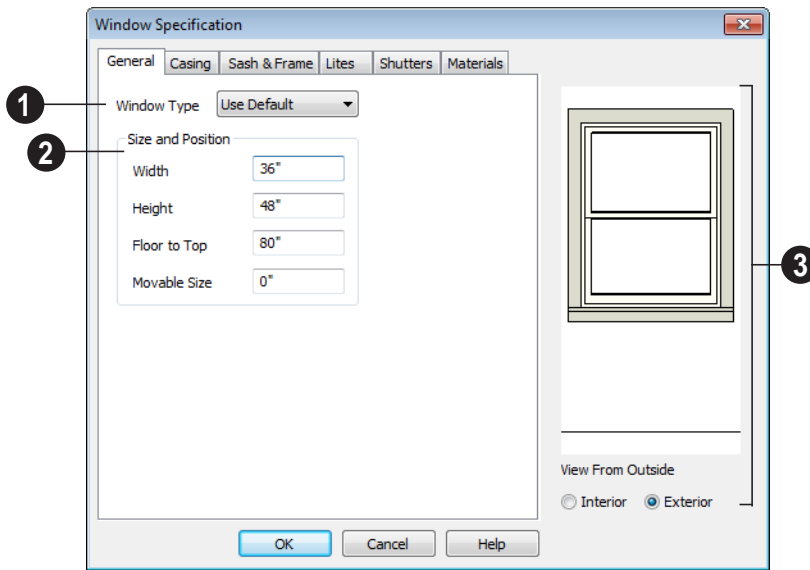

1 Window Type - Select the type of window from the list. The first entry in the list is the Default type set in the **Window Defaults** dialog.

2 Specify the **Size and Position** of the selected window.

- Specify the **Width** and **Height** of the window.
- **Floor to Top** - Specify the height of the top of the window frame as measured from the subfloor.
- **Movable Size** - Specify the dimension of the movable portion of the window. A value of 0 defaults the movable size to

whatever is normal for that type of window. Not available for Fixed Glass, Single or Double Casement, Single Awning or Hopper, Louvered, Pass-Thru or mullied units.

- **Louver Size** - Specify the vertical height of the selected window's louvers. Only available for Louvered windows.

3 A preview of the selected window displays here.

- Select **Interior** or **Exterior** to specify which side of the window displays in the preview.

Casing Tab

Changes made on the Casing tab can only be seen in 3D views.

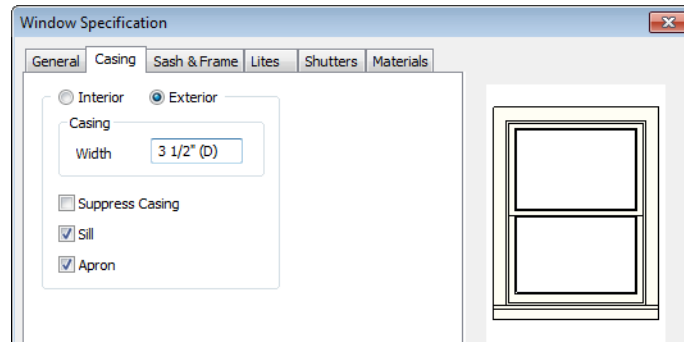

Specify the casing for the selected window or mullied unit.

- Select the **Interior** or **Exterior** radio button to define the casing for that window side and display it in the preview image.
- Define the **Width** of the selected casing.
- Check **Suppress Casing** to have a wrapped opening instead of casing on the selected side of the window.
- Check **Sill** to have a sill on the selected side of the window.
- Check **Apron** to include an apron under the sill.

Sash & Frame Tab

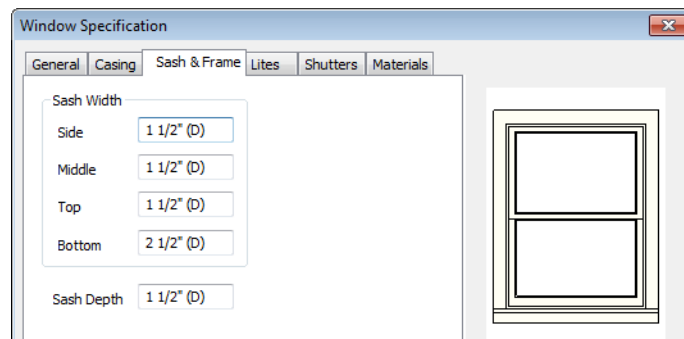

1 Specify the size and position of the **Sash**. Increasing the Side, Middle, Top or Bottom decreases the area of the glass.

- Specify the **Side** width of all vertical sash members: those at the window sides as well as the central members of casement and sliding windows. This is also the
- width of the top portion of the window when an arch is specified.
- Specify the **Middle** width of horizontal components between the top and bottom sash in double hung, double and triple awning, and double and triple hopper

- windows. It does not affect casement and sliding windows.
- Specify the **Top** and **Bottom** sash widths. The **Top** value is not used if the window has an arch.

- Specify the **Depth**, or thickness, of the sash stock measured from the exterior to the interior.

Lites Tab

The Lites tab allows you to add muntins to various window styles. There are four possible styles of muntin bars.

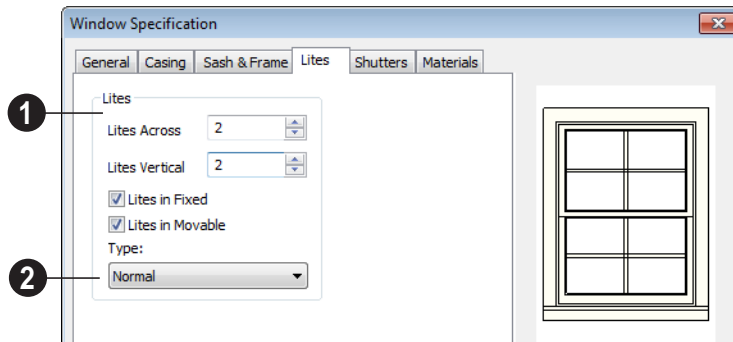

- Specify the number, position and style of **Lites** for the selected window.
 - Enter the number of horizontal **Lites Across** in each sash.
 - Enter the number of vertical **Lites Vertical** in each sash.
 - Check or uncheck **Lites in Fixed** and **Lites in Movable** to specify either one or both of the sashes to have divided lites.

Note: Because the fixed window in a Triple Sliding window is twice the size of the movable windows, the fixed section has a vertical muntin bar. To eliminate this, clear the Lites in fixed check box.

- Select a **Type**, or style, of window lite from the drop-down list.

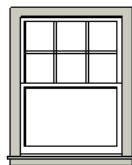

Lites in Fixed

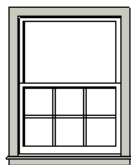

Lites in Movable

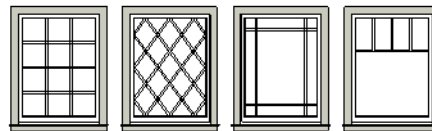

Normal Across = 3 Vertical = 4	Diamond Across = 3 Vertical = 3	Prairie Across = 6 Vertical = 8	Craftsman Across = 4 Vertical = 3
--------------------------------------	---------------------------------------	---------------------------------------	---

- Normal** style is the most common, with muntins going horizontally and vertically.

Colonial windows are an example of the normal style.

- **Diamond** style uses angled muntin bars to divide up the lites. French windows are an example of the diamond style.
- **Prairie** style is based on the normal style, but with all the central muntin bars removed, leaving only the two outside muntin bars both horizontally and vertically. Typically, both Lites Across and

Lites Vertical should be set between 6 and 8. Federal or Federation windows are an example of the Prairie style.

- **Craftsman** style is based on the normal style, but only the topmost horizontal muntin bar is kept with all the portions of the vertical muntin bars above it. Typically, both Lites Across and Lites Vertical should be set between 4 and 8.

Shutters Tab

The settings on the Shutters tab allow you to specify exterior shutters for the selected window.

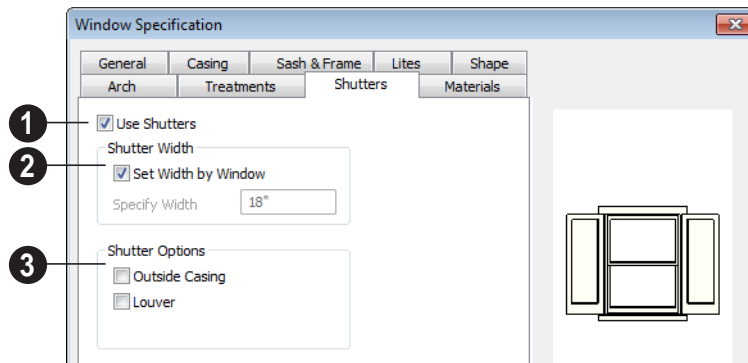

- 1 Check **Use Shutters** to apply shutters to the selected window's exterior and enable the settings below.
- 2 Specify the **Shutter Width** for the selected window.
- Uncheck **Set Width by Window** to type a width in the **Specify Width** field. If the window is later resized, the shutters width will not adjust in response.

- When **Set Width by Window** is checked, a shutter width exactly half that of the window, excluding casing, is used.
- 3 Additional **Shutter Options** can be specified here.
- Check **Outside Casing** to position shutters outside the window casing, as decorative shutters often are. Uncheck this to position the shutters just outside the window frame, like functional shutters.

- Check **Louver** for louvered shutters. Uncheck this for solid shutters. If Outside Casing is checked, the louvers face outward, away from the wall; if checked, louvers face toward the wall.

A preview of the selected window displays on the right.

- Select **Interior** or **Exterior** to specify which side of the window displays in the

preview. In order to see exterior shutters in the preview, Exterior must be selected.

Materials Tab

The settings on the Materials tab are the same as those found on the same tab in dialogs throughout the program. See “Materials Tab” on page 303.

Bay/Box/Bow Window Specification Dialog



To open the **Bay/Box Window Specification** dialog, select a bay, box or bow window and click the **Open Object** edit button.

The options in this dialog can only be set for objects placed in a plan: bay, box, and bow windows do not have defaults dialogs.

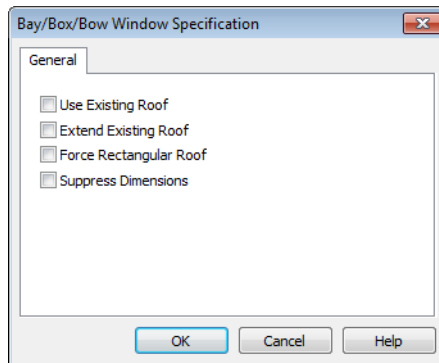

Specify the structure of the **Roof** over the selected window unit. See “Bay, Box, Bow Windows & Roofs” on page 162.

- Check **Use Existing Roof** if the existing roof needs no changes to accommodate the bay window.
- Check **Extend Existing Roof** to extend the existing roof plane to cover the bay window below.
- Check **Rectangular Roof** to create a roof over the bay window that is square across the end instead of following the profile of the roof.
- Check **Suppress Dimension** to suppress the automatically-produced dimensions that show the size of the window unit in floor plan view.

Multiple Floors

When a new plan file is opened in Home Designer Essentials, two floor levels are present: Floor 1 and the Attic Floor. You can add more floors whenever you like: up to 3 total. Once created, floors can also be copied and deleted.

Home Designer Essentials also supports special floors for foundations and attics. Only one foundation level and one attic can exist in a plan. Foundations are discussed in their own chapter. See “Foundations” on page 178.

Chapter Contents

- Floor Defaults Dialog
- Floor Tools
- Adding Floors
- Displaying Floors
- Deleting Floors
- Split Levels
- The Current Floor
- The Attic Floor
- The Reference Floor

Floor Defaults Dialog



There is a **Floor Defaults** dialog for each floor in a plan file. The defaults for the current floor can be accessed by selecting **Edit > Default Settings**. Select “Floor” from the category tree and click the **Edit** button to open the **Floor Defaults** dialog for the currently active floor. See “Default Settings vs Preferences” on page 47.

The **Floor Defaults** dialog also opens whenever you add a new floor to the plan. See “Adding Floors” on page 172.

The **Floor Defaults** dialog does not open when you build a foundation; however, the

Floor 0 Default settings are created based on the current Foundation Defaults. See “Building a Foundation” on page 179.

The **Floor Defaults** dialog is similar to the **Room Specification** dialog, but controls the default settings for all rooms on the current floor. The settings here also control the height of individual walls as they are drawn on the floor in question. See “Room Specification Dialog” on page 131.

Note: The default floor height for Floor 1 is 0. It can be modified in the Room Specification dialog, but not in the Floor 1 Defaults dialog. See “Floor and Room Defaults” on page 121.

General Tab

Only one setting on the General tab is unique to the **Floor Defaults** dialog.

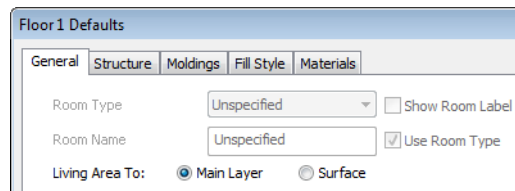

On Floor 1 only, define the wall layer that you would like to calculate the **Living Area To**. See “Living Area” on page 127.

Structure Tab

The settings on the Structure tab are similar to those in the **Room Specification** dialog. See “Structure Tab” on page 132.

Moldings Tab

The settings on the Moldings tab are similar to those in the **Room Specification** dialog. See “Moldings Tab” on page 134.

Fill Style Tab

The settings on the Fill Style tab are similar to those in the specification dialogs for many

objects throughout the program. See “Fill Style Tab” on page 225.

Materials Tab

The settings on the Materials tab are similar to those in the specification dialogs for many objects throughout the program. See “Materials Tab” on page 303.

Floor Tools



Select **Build> Floor** to access the floor tools.



Select **Build> Floor> Build New Floor** to build a new floor. A new floor can be generated based upon the perimeter of the floor below or a blank floor can be created and drawn from scratch. See “Adding Floors” on page 172.



Choose **Build> Floor> Build Foundation** to open the **Foundation Defaults** dialog and build a foundation floor. See “Building a Foundation” on page 179.



Select **Build> Floor> Delete Foundation** to remove the foundation from the plan. See “Deleting Foundations” on page 182.

Adding Floors

New floors can be added in floor plan view and 3D views.

To create a new floor

1. Select **Build> Floor> Build New Floor**  to open the **New Floor** dialog.

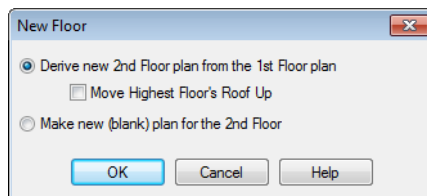

2. Select the options that you need and click **OK**.
 - **Derive new 2nd floor plan from the 1st floor plan** creates a new top floor

with exterior walls generated directly over the exterior walls of the floor below. Wall types and roof directives associated with the walls on the floor below are duplicated; however, interior walls are not. See “Roof Tab” on page 115.

- Check **Move Highest Floor’s Roof Up** to move any roof planes displaying on the highest floor in the plan up one floor when the new floor is created. Roof planes displaying on floors other than the top floor are unaffected. This option is only available if there are roof planes built on the top floor and is not available when **Auto Rebuild Roofs** is enabled. See “Build Roof Dialog” on page 192.
- **Make new (blank) plan for the 2nd floor** creates a new top floor that is

blank. This option is typically selected only if none of the exterior walls on the new floor will be directly above the exterior walls on the floor below. If you choose this method, it may be helpful to turn on the Reference Display when drawing walls on the new floor. See “The Reference Floor” on page 176.

3. The **Room Defaults** dialog for the newly created floor opens next. Make any necessary changes to the floor structure, moldings, or materials and click OK. See “Floor Defaults Dialog” on page 171.

4. The new floor becomes the current floor in floor plan view. If, however, the new floor is created in a 3D view, the camera remains on its original floor and does not move.

Note: Home Designer Essentials allows only one floor, the foundation/basement, below the first floor. Keep this in mind when you begin an as-built or plan for a multi-story building.

Adding a Foundation

To add a foundation, select **Build> Floor>**

Build Foundation . See “Building a Foundation” on page 179.

Displaying Floors

Home Designer Essentials allows you to view the floors in your plan in a variety of ways.



In Floor Plan View

In floor plan view, only one floor can be active for editing at a time. This is referred to as the Current Floor. See “The Current Floor” on page 175.

In addition to the Current Floor, one other floor can be displayed for reference purposes: the Reference Floor. Objects on the Current Floor can snap to those on the Reference Floor, helping you align objects. See “The Reference Floor” on page 176.

In 3D Views

In most 3D views, all floors in a plan are visible, from the foundation up to the attic. There are two exceptions:

- **Doll House View** .
- Interior **Elevation**  views.

Doll House Views show the Current Floor only, not including its ceiling, while interior **Elevation** views show a wall on a single floor in a single room. See “3D View Tools” on page 320.

Deleting Floors



Select **Build> Floor> Delete Current Floor** to remove the current floor from the plan. If there is a floor above, it becomes the current floor; if there is no floor below, the floor beneath becomes the current floor.



To delete Floor 0, select **Build> Floor> Delete Foundation**. You can

delete the foundation without actually being on Floor 0. Floor 0 cannot be deleted while **Auto Rebuild Foundation** is turned on. See “Deleting Foundations” on page 182.



When a floor is deleted, all objects on that floor are deleted with it.

Stepped Floor & Ceiling Platforms

Each floor has default floor and ceiling heights. You can, however, use the **Room Specification** dialog to specify floor and ceiling heights on a room by room basis to create stepped floors and ceilings. See “Structure Tab” on page 132.

If you require a single floor platform with a uniform height and thickness but different ceiling heights for the rooms below, specify a lowered ceiling using the **Ceiling Finish Specification** dialog. See “Lowered Ceilings” on page 129.

Split Levels

Both split level floor plans and split level entries can be created by controlling the floor and ceiling heights of individual rooms in a multiple story structure.

Split Level Floor Plans

A split level, or tri-level, structure is a building where the floor level in one part of the plan is located approximately half way between the floor and ceiling levels of another part of the plan.



Split Level Home

To create a simple split level plan

1. Draw a simple rectangular structure divided into two separate halves by an interior wall.

2. Select one of the rooms and click the **Open Object**  edit button. See “Room Specification Dialog” on page 131.
3. Raise the **Floor Height** then press the Tab key.
4. Restore the **Relative Rough Ceiling** to the default value, then click OK.
5. Build a stem wall foundation. See “Foundations” on page 178.
 - The foundation under the room with the lower floor height will have the specified Min Stem Wall Height.
 - The foundation under the room with the raised floor will have taller stem walls.
 - Both can be edited in the **Room Specification** dialog.
6. If you add a Floor 2, note that the **Ceiling Height** in the room on Floor 1 will be reset to the default value.
 - To maintain a stepped condition on multiple floors, return to this room and set the **Relative Rough Ceiling** back to using the default.



Split Level Entries

A split level entry, or divided entry, is characterized by an entry door that opens onto a landing positioned half way between the basement floor and first floor levels.



Split Level Entry

To create a simple split level entry

1. Create a plan file with a full basement at the location of the entry door. See “Basement Rooms” on page 183.
2. Go to Floor 0 and draw a stair **Landing**  at the location of the entry. See “Landings” on page 211.
3. Draw stairs upward from the basement floor to the landing.
 - The number of treads and risers in the stair section will determine the landing height.
4. Draw a second stair section from the landing upward.
5. Select the stairs and click the **Auto Stairwell**  edit button. See “Creating a Stairwell” on page 215.

Split level entries are often associated with daylight basements. See “Daylight Basements” on page 184.

For more detailed instructions, visit www.HomeDesignerSoftware.com.

The Current Floor

Only one floor can be active at any given time. The active floor is referred to as the

Current Floor, and it is the only floor on which objects can be edited.

If you want to edit two different floors at the same time, you can open the plan again. This opens a second window on the current open plan that has the same editing abilities as the first. Only one of these windows can be active at any given time.

Floor Up / Floor Down



If you are working with more than one floor, you can select **Tools> Reference Floors> Up One Floor** or **Down One Floor** to switch from one floor to another.

You can change the current floor in floor plan and 3D views. The current floor displays on

the **Change Floor/Reference**  button, which can be found between the **Down One Floor** and the **Up One Floor** buttons.

Floors become available once they have been built. The Attic and foundation levels are also accessible using these tools.

Change Floor / Reference



If there are multiple floors, select **Tools> Reference Floors> Change Floor/Reference** to open the **Change Floor/Reference** dialog, where you can select both the current floor and which floor is used in the Reference Display, as well as control the appearance of the Reference Display.

The Attic Floor



Home Designer Essentials automatically creates a floor above the top numbered floor level of each plan. This floor is called the Attic floor and has only one purpose: to provide a space for automatically generated Attic walls. See “Attic Walls” on page 112.

Because the Attic floor is not meant to be a living area, a warning message will display if

you try to draw walls or other objects on this floor.

In some situations, you may find it necessary to draw one or more walls on this floor; however, even if you enclose an area with walls, rooms cannot be created on the Attic floor.

If you wish to create an attic loft, bonus room, or storage area in your plan, you will need do so on a numbered floor level.

The Reference Floor

When there is more than one floor in a model, it is often helpful to see how different floors relate to each other. Any floor can be shown as the **Reference Floor** along with the current floor.

When the Reference Display is turned on, the floor that you were last on prior to the current floor is used as the Reference Floor. Objects on the Reference Floor cannot be selected or edited.

Reference Display



To display the Reference Floor, select **Tools > Reference Floors > Reference Display** or press F9 on your keyboard.

If the Reference Display is turned on when a view is printed, it will be included in the printed output. See “Display Options and Printing” on page 382.

Note: If objects on the current floor and the Reference Floor have edges that line up, the Reference Floor may be difficult to see on screen. When lines of two different colors are superimposed upon each other, discoloration may result.

Reference Display Options



The display of objects in the Reference Display is controlled by selecting **Tools > Reference Floors > Reference Display Options**. See “Display Options Dialog” on page 60.

Change Floor / Reference



By default, the floor below the current floor is the Reference Floor, but any

floor can be referenced using the **Change Floor/Reference** dialog. To open the dialog, select **Tools > Reference Floors > Change Floor/Reference** button.

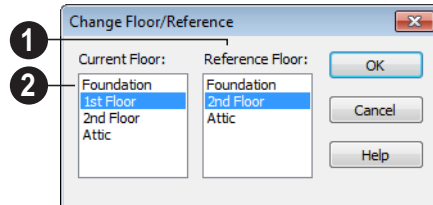

- 1 The **Reference Floor** currently used for reference is highlighted here. You can select another floor.
- 2 The **Current Floor** is highlighted here. You can select another floor to make it the current floor.

Swap Floor/Reference



If one floor is defined as the current floor and another floor is defined as the reference floor, select **Tools > Reference Floors > Swap Floor/Reference** to switch the status of the two floors.

Foundations

There are two foundation types in Home Designer Essentials: stem walls with footings and monolithic slab. The foundation type can be specified in the **Foundation Defaults** dialog when the foundation is built.

There can be only one foundation level in your plan, Level 0. Foundation walls can be drawn on upper floors using the **Wall** tool.



Always consult registered geotechnical and civil engineers for information regarding the proper foundation for your site.

Chapter Contents

- Foundation Defaults
- Building a Foundation
- Displaying Foundations
- Editing Foundations
- Deleting Foundations
- Foundations and Rooms
- Foundations and the Terrain
- Fireplaces
- Fireplace Specification Dialog
- Library Fireplaces
- Chimneys

Foundation Defaults



Foundation Defaults can be accessed by selecting **Edit> Default Settings**.

Select “Foundation” and click the **Edit** button to open the **Foundation Defaults** dialog.

The settings in the **Foundation Defaults** dialog are similar to those in the **Build**

Foundation dialog, which opens when

Build> Floor> Build Foundation  is selected. The primary difference is that when you click **OK** in the **Foundation Defaults** dialog, no changes are made to the model. See “Building a Foundation” on page 179.

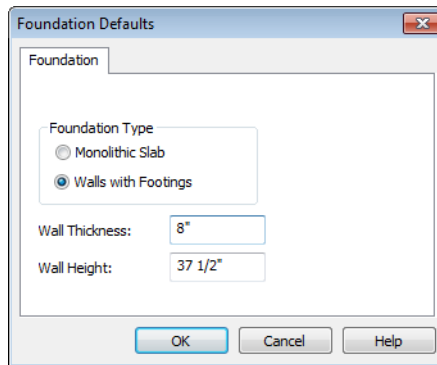

Click the radio button beside either **Monolithic Slab** or **Walls with Footings** to specify which foundation type the program should build.

Wall Thickness - Specify the desired thickness of the foundation wall. See “Wall Thickness” on page 109.

Wall Height - Specify the desired height of the foundation walls.

If the wall height is at least 6 feet (1800 mm), a slab floor is generated above the footings and inside the foundation walls. The Wall Height includes the thickness of this slab.

If you do not want this slab, specify the “rooms” on Floor 0 as **Open Below** in the **Room Specification** dialog. See “Available Room Types” on page 124.

Building a Foundation



Two foundation types are available: stem walls with footings and monolithic slabs. The first option is created

using walls; the second creates concrete slabs with footings.

Automatically built foundations are placed on Floor 0 and are based on wall positions and floor heights on Floor 1. Foundation walls or slab footings are generated under:

- All exterior walls on Floor 1 that define a room other than a Court, Deck or Balcony room type. See “Room Definition” on page 121.
- Any interior walls on Floor 1 defining rooms with different floor heights. See “Floor & Ceiling Heights” on page 128.

At least one room must be defined on Floor 1 for a foundation to be automatically generated. If no rooms are defined on Floor 1, a blank Floor 0 is created.

Once a foundation is generated, you can add interior walls to customize it.

To build an automatic foundation

1. Select **Build> Floor> Build Foundation** .

2. Specify the desired foundation type and other information in the **Build Foundation** dialog. The settings in this dialog are similar to those in the Foundation Defaults dialog. See “Foundation Defaults” on page 179.
3. In the **New Floor** dialog, select **Derive new Foundation plan from the 1st floor plan** and click **OK** to build a foundation based on Floor 1.

If you prefer, you can instead select **Make new (blank) plan for the Foundation** to create an empty foundation level where you can manually draw foundation walls or slabs.

In most cases, it is preferable to base Floor 0 off the first floor plan and then manually edit the foundation as needed. See “Editing Foundations” on page 181.

Displaying Foundations



The display of foundation walls, slabs, curbs and footings is controlled in the **Display Options** dialog. See “Display Options Dialog” on page 60.

- Foundation Walls, including slab footings and Garage curbs, are placed on the “Walls, Foundation” layer.
- Footings under Foundation Walls and slab footings are placed on the “Footings” layer.

In floor plan view, foundation walls are drawn with solid lines and footings, with dashed lines.

If a door on Floor 1 extends into a stem wall or curb defining a Garage room, its location will be indicated on Floor 0.

In 3D views, all objects on Floor 0 will only display when the “Foundation” layer is turned on.

While the display of foundation walls and their footings can be controlled independent of one another in floor plan view, in 3D views this is not the case. If a foundation wall is set to display, its footing will as well - even if the “Footings” layer is turned off. The

reverse is also true - if a foundation wall's display is turned off, so will its footing's.

The display of monolithic slab foundations in 3D views is controlled by the "Foundation" layer. Slab footings are located on the

"Walls, Foundation" layer; but if this layer is turned off, any slab footings that define a foundation room will continue to display as long as the "Foundation" layer is on.

Editing Foundations

Stem wall with footings and monolithic slab foundations are both created using walls which enclose room areas.

- Foundation walls can be selected and edited much like other walls. See "Editing Walls" on page 107.
- Foundation rooms can also be selected and edited like other rooms. See Foundations and Rooms.

Rebuilding Foundations

By default, foundations do not update automatically when changes are made to the structure on Floor 1. For example, if exterior walls are moved or floor platforms are raised or lowered, the foundation must will be rebuilt.

If you prefer that the foundation not rebuild automatically, you can uncheck **Auto Rebuild Foundation** in the **Foundation Defaults** dialog. See "Foundation Defaults" on page 179.

You can rebuild an automatically generated foundation by selecting **Build> Floor>**

Build Foundation  from the menu.

Changing Foundation Types

When a foundation is generated, the program creates **Floor Defaults** settings for Floor 0

based on the information in the **Build Foundation** dialog. If you specify a Monolithic Slab foundation, the default Floor Structure on Floor 1 will also be changed to a slab rather than a framed platform. See "Floor Defaults Dialog" on page 171.

If you rebuild the foundation using a different Foundation Type, it is advisable to check the floor heights of all rooms on Floor 1 - particularly Garage and Slab rooms, as well as any rooms that do not use the default floor height of 0".



To avoid unexpected results, it is recommended that you not change the Foundation Type once the foundation is built.

Stem Wall Height

When a foundation is created, all of Floor 0 uses the stem wall height specified in the **Foundation Defaults** dialog,

This height is measured from the bottom of floor platform of Floor 1 to top of the stem walls' footings. If Floor 1 has multiple floor platform heights, the foundation stem walls will be stepped.

Once a foundation is created, stem wall heights can be adjusted either on a room-by-room basis or for individual walls.

To change a room's stem wall height

1. Select a room on Floor 0 and click the **Open Object**  edit button.
2. Specify the desired **Stem Wall Height** in the **Room Specification** dialog. See “General Tab” on page 131.

3. If you wish to reduce the **Stem Wall Height**, you will first need to reduce the **Ceiling Height** value by the same amount.

If adjacent rooms have stem wall heights that differ by at least 1/16 of an inch, the stem wall separating them uses the larger of these two values.

Deleting Foundations



Select **Build> Floor> Delete Foundation** to delete the entire foundation floor.

You can also select and delete individual foundation walls and slabs by clicking the

Delete  edit button or pressing the Delete key. See “Deleting Objects” on page 93.

Deleting and rebuilding the foundation is often the quickest way to update the model when substantial changes are made to Floor 1 after the foundation is built.

Foundations and Rooms

When a foundation plan is created, rooms included in the Living Area calculation generate a stem wall or slab foundation below them. Garage rooms generate slab foundations, but exterior rooms such as Decks, Courts and Balconies do not generate any foundation.

Interior foundation walls are not generated unless:

- They separate the area under a Slab or Garage room from the rest of the plan;
- They define areas under rooms with different floor heights.

Note: To remove all or part of the concrete slab in the basement area, select a basement room and define it as Open Below in the Room Specification dialog.

Garages

When a foundation is generated based on the floor plan of Floor 1, a room on the first floor specified as either a Garage or Slab type will receive a foundation with a slab floor and stem walls. If a monolithic slab foundation is generated, the room will receive a slab floor with curbs.

By default, a room on Floor 1 specified as a Garage or a Slab will be assigned a lower floor height when the foundation is built. The

amount that it is lowered depends on the foundation type:

- The floor height will drop the default thickness of the floor platform for Floor 1 plus 12" (300 mm) - a total of 24 5/8" (618 mm) - in a Walls with Footings foundation.
- The floor height will drop 3 1/2" (88 mm) in a Monolithic Slab foundation.

To build a Garage slab with stem walls

1. Before the foundation is generated, specify the room as a Garage or Slab.
2. Build a Wall with Footings foundation.

To build a Garage slab with curbs

1. Before the foundation is generated, specify the room as a Garage or Slab.

2. Build a Monolithic Slab foundation, specifying the required Lower Garage Floor value.

Basement Rooms

When a foundation's type is Walls with Footings and it is assigned a Minimum Wall Height of 76" (1900 mm) or greater, the resulting basement is automatically created with a 4" (100 mm) concrete slab floor.

Similarly, if a foundation is set up to have a Basement Ceiling Height of 72" (1800 mm) or greater when built, it is automatically given a painted drywall Ceiling Finish.

Regardless of its ceiling height, however, you can specify a ceiling finish for any room in the **Room Specification** dialog. See "Structure Tab" on page 132.

The resulting basement can be divided into separate rooms using **Interior Walls**  or any wall type you wish.

Foundations and the Terrain

Home Designer Essentials automatically positions the terrain a set distance below Floor 1. See "Terrain Height vs Floor Height" on page 259.

In a plan with a foundation present, this distance will be:

- 6" (187 mm) below the top of the stem walls in a Walls with Footings foundation.
- 8" (200 mm) below the top of the slab in a Monolithic Slab foundation.

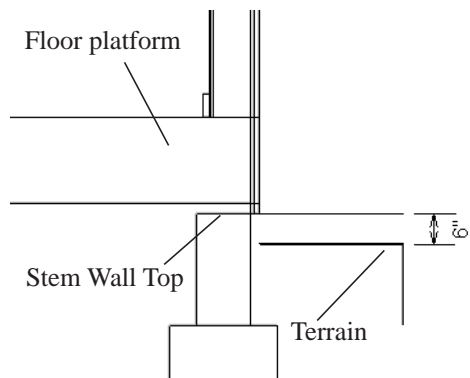

Not all foundations have these requirements, of course, so you can customize your foundation and terrain to suit your needs.

Daylight Basements

Daylight basements, also referred to as look-out basements, have walls that are tall enough for basement windows to be positioned above the terrain. They are often found in split level or split entry structures.

To create a daylight basement condition, build a stem wall foundation and modify these settings in the **Terrain Specification** dialog:

- Uncheck **Auto Calculate Elevation**.
- Increase the **Building Pad Elevation**, which is the distance between the default floor height of Floor 1 and the terrain.

Stepped Foundations

A stepped foundation will be produced automatically if more than one floor height is present on Floor 1 when the foundation is built.

You can also create a stepped foundation by editing foundation rooms. See “Stem Wall Height” on page 181.

Fireplaces



A masonry fireplace can be placed in or away from a wall by selecting **Build> Fireplace** and then clicking in the drawing area.

- If created in a wall, it is considered a wall opening and can be moved or resized like a window or door.
- If created away from a wall, it moves and resizes similar to a cabinet.

A selection of prefabricated metal fireplaces is also available from the Fixtures (Interior) library category. These can be framed in with standard walls. See “The Library” on page 282.

The display of fireplaces is controlled in the **Display Options** dialog. See “Display Options Dialog” on page 60.

Fireplaces are edited, moved, resized, and deleted similar other objects. See “Editing Objects” on page 70.

Built into a Wall

To place a masonry fireplace in a wall, select **Build> Fireplace**  and click on a wall. A fireplace is created with the outside of the fireplace flush with the outside of the wall.

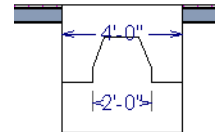

Select the fireplace to display four edit handles located along the wall.

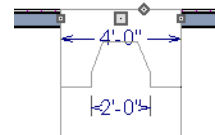

Click the diamond-shaped Depth handle and drag toward the outside of the wall. The

fireplace will stop when the firebox front is flush with the inside edge of the wall.

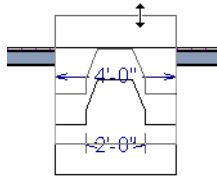

In 3D views, fireplaces placed in walls display five edit handles: a Resize handle along each edge and a Move handle at the center.

Fireplaces always face the interior when placed on an exterior wall. When placing a fireplace in an interior wall, click on the edge of the wall that you want the fireplace to face. The fireplace is created with the firebox on the same side as the wall edge you clicked on to create it.

Freestanding

To place a free-standing masonry fireplace, select **Build > Fireplace**  and click in an open area away from a wall.

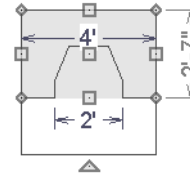

Unlike fireplaces placed in walls, free-standing fireplace have ten edit handles when selected and may be rotated, resized, or moved in any direction, similar to the way CAD boxes can. See “Editing Box-Based Objects” on page 82.

Fireplace Foundations

When a Walls with Footings foundation is built, a fireplace foundation will be generated under any **Fireplaces**  present on Floor 1. See “Building a Foundation” on page 179.

Fireplace foundations are the same material type as the original fireplace, but do not have a firebox or a hearth. Fireplace foundations can be edited or deleted as needed. A firebox and hearth can be added in the **Fireplace Specification** dialog.

Fireplace Specification Dialog



Select a masonry fireplace and click the **Open Object** edit button to display the **Fireplace Specification** dialog.

Dimensions in this dialog here must be entered in whole inches. Fractions and decimals are not accepted.

General Tab

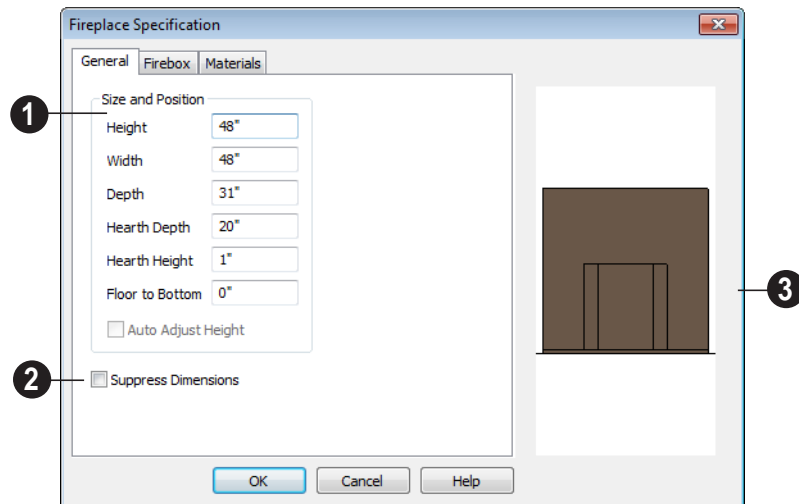

- 1 Specify the **Size and Position** of the selected fireplace and its hearth.
 - Specify the **Height** of the fireplace.
 - Specify the **Width** of the fireplace.
 - Specify the **Depth** of the fireplace.
 - Specify the **Hearth Depth**. This is measured from the front of the fireplace out into the room. To eliminate the hearth altogether, enter a zero for this value.
 - Specify the **Hearth Height**, relative to the floor in that room.
 - Enter the **Floor to Bottom** distance from the floor to the bottom of the hearth.
 - When the selected free-standing fireplace is outside a room and **Auto Adjust**

Height is checked, its Floor to Bottom height is measured relative to the terrain height. When this is unchecked, the Floor to Bottom height is measured from the default floor height of Floor 1. Only available for free-standing fireplaces. See “Terrain Height vs Floor Height” on page 259 of the Reference Manual.

- 2 Check **Suppress Dimensions** to turn off the display of the selected fireplace’s width and firebox width dimensions in floor plan view.
- 3 The preview image of the fireplace updates as changes are made. Press the Tab key to update to the most recent change.

Firebox Tab

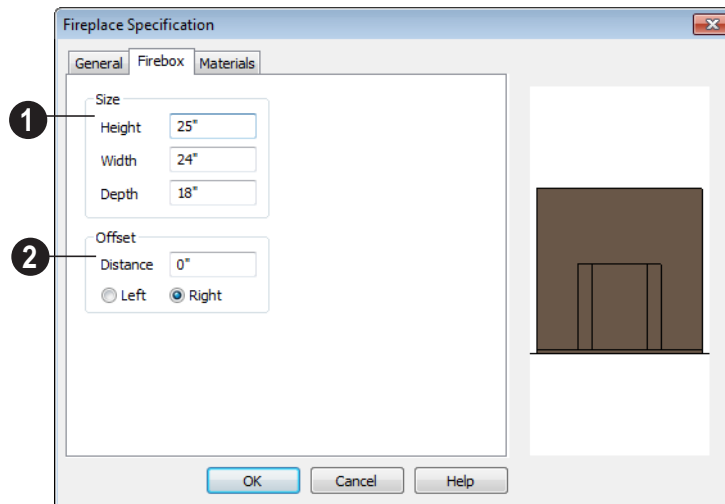

- 1 Define the **Size** of the selected fireplace's firebox.
 - Specify the firebox's **Height** and **Width**.
 - Specify the **Depth** of the firebox.
 - The defaults are 25, 24, and 18 inches respectively.
- 2 Define the firebox **Offset**, measured from the center of the fireplace.

- Enter offset **Distance**, which is how far the firebox is offset from the fireplace center. A value of 0 centers the fire box in the fireplace.
- **Offset to Left/Right** - Choose to offset the firebox to the left or to the right.

Materials Tab

For information about the settings on this tab, see "Materials Tab" on page 303.

Library Fireplaces

A variety of different fireplace symbols are available in library. The fireplace symbols in the Library behave just like other Library objects. See "The Library" on page 282.

 Always check the manufacturer's product information for the framing and clearance requirements of the fireplace unit you plan to use, and design your plan accordingly

Placing a Library Fireplace

A variety of fireplace symbols are available in the library. See “Placing Library Objects” on page 293.

Flush fireplaces are designed to snap to wall surfaces.

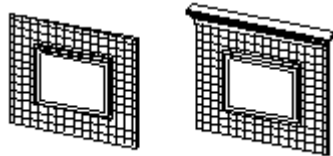

Flush Fireplace Flush Fireplace

Some fireplace symbols can be enclosed by walls or positioned to project through a wall.

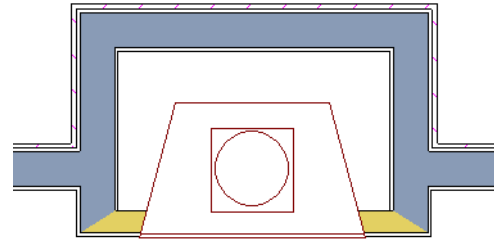

Open Front fireplace projecting through a wall

Chimneys

Chimneys can be created using a variety of methods.

Masonry Fireplace Chimneys

To create a chimney on a masonry fireplace

1. Select the fireplace in a 3D view.
2. Ctrl + drag the top edge of the chimney upward through all the floors and the roof until it is to the desired height. See “Unrestricted Movement” on page 88.
3. When the chimney is approximately the correct height, select the fireplace, click the **Open Object**  edit button, and type in the exact height.

Chimney Chases & Caps

There are two ways to draw a chimney chase.

- Place a closed box geometric shape or soffit in position over the chimney chase, resize it to match, then increase its height either in its specification dialog or in a 3D view using the same method as extending a masonry fireplace.
- Define the chimney chase as a room area using walls, making sure these walls are aligned between floors. The chimney chase “room” on the uppermost floor should have a much higher ceiling than the other rooms on that floor and should also have no ceiling or roof. See “Room Specification Dialog” on page 131.

A selection of chimney tops is available in the library. In addition, custom chimney caps can be made using Geometric Shapes and/or soffits. See “General Shapes” on page 276 and “Soffits” on page 276.

Roofs

Home Designer Essentials's automatic Roof Tools allow you to draw almost any roof style.

Proficiency with the Roof Tools can only be attained through practice, but mastering these tools saves you time and effort in plan development. For information about creating specific roof styles, see "Roof Tutorial" on page 61 of the User's Guide.

Chapter Contents

- Roof Defaults
- The Roof Tools
- Automatic Roofs
- Build Roof Dialog
- Editing Roofs
- Skylights
- Roof Hole/Skylight Specification Dialog
- Roof Pitches in Degrees

Roof Defaults



Select **Edit> Default Settings**, to open the **Default Settings** dialog for a variety of drawing tools, several of which directly affect roof generation.

Build Roof Dialog

While not listed in the **Default Settings** dialog, the **Build Roof** dialog functions as the defaults dialog for roofs. Many, but not all, initial default values for automatically generated roofs are set in this dialog. See “Build Roof Dialog” on page 192.

Floor and Ceiling Heights

The initial heights of floors and ceilings, which influence roof heights, are specified in

the **Floor Defaults** dialog for each floor. See “Floor Defaults Dialog” on page 171.

The floor and ceiling heights in individual rooms also influence roof heights and are specified in the **Room Specification** dialog. See “Structure Tab” on page 132.

Wall Specification Dialog

By default, when a roof is built, a roof plane is generated over each exterior wall, creating a hip roof.

Any deviations from this default hip roof, such as a gable or a different pitch, can be specified in the **Wall Specification** dialog for any exterior wall. See “Roof Tab” on page 115.

The Roof Tools



Select **Build> Roof** to access the Roof Tools.

Build Roof



Select **Build> Roof> Build Roof** to open the **Build Roof** dialog, specify the settings for automatically generated roof planes, and build or rebuild a roof. See “Build Roof Dialog” on page 192.

When roofs are automatically generated, a roof plane is created over each exterior wall by default, resulting in a hip roof.

To automatically generate a roof plane using values other than the defaults or to not generate a roof plane bearing on a particular

wall (as with a gable or the sides of a shed roof), you can change the settings in the **Wall Specification** dialog. See “Roof Tab” on page 115.

For more information about creating different roof styles, see “Roof Tutorial” on page 61 of the User’s Guide.

Skylight



Select **Build> Roof> Skylight**, then draw a rectangle over an existing roof plane to create a skylight. The skylight, skylight shaft, and ceiling hole (if a ceiling exists) are drawn at the same time. See “Skylights” on page 195.

Delete Roof



Select **Build> Roof> Delete Roof** to delete all roof planes in the plan. See “Deleting Roof Planes” on page 194.

Automatic Roofs

When roofs are automatically generated, a roof plane is created over each exterior wall by default, resulting in a hip roof.

For more information about creating different roof styles, see “Roof Tutorial” on page 61 of the User’s Guide.

Roof Directives in Walls

To automatically generate a roof plane using values other than the defaults or to not generate a roof plane bearing on a particular wall (as with a gable or the sides of a shed roof), you can change the settings in the **Wall Specification** dialog for that wall. See “Roof Tab” on page 115.

Rebuilding Roofs

When changes are made to the model, the roof does not update to reflect these changes.

You can rebuild the roof at any time to reflect the current state of the model by opening the **Build Roof** dialog and clicking OK.

Build Roof Dialog



The **Build Roof** dialog is used to automatically build or rebuild roof planes. To open the **Build Roof** dialog, select **Build> Roof> Build Roof** .

Roof planes are generated based on the positions and roof directive settings for each exterior wall in the plan. If you make changes to any of these walls, you will need to build the roof again for them to take effect. See “Roof Tab” on page 115.

There are three tabs in the **Build Roof** dialog:

- Roof Tab
- Materials Tab
- Roof Styles Tab

Roof Tab

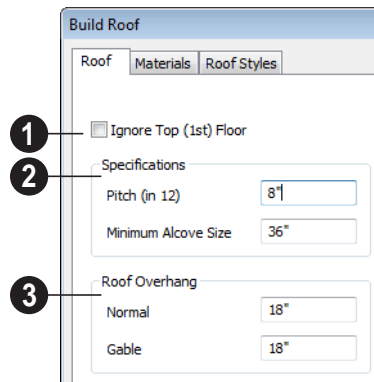

1 Check **Ignore Top Floor** to build the roof so that it bears on the walls of the floor below the top living floor in the plan. When unchecked, the roof builds so that it bears on the walls on the top floor of the plan.

2 The options in the **Specifications section** are basic roof structure settings.

- Enter a value to describe the **Pitch** as a ratio over 12. For a conversion to degrees, see “Roof Pitches in Degrees” on page 198.
- **Min. Alcove** - Specify the minimum width of an alcove (depression into an otherwise straight exterior wall). Any alcove less than the specified width is treated as though the exterior wall continues straight across. Alcoves that measure wider than this value are not roofed over; they cause a change in roof planes.

Following is an example showing this difference. If **Min Alcove** is 36", a 36" wide alcove requires a change in the roof line. Each wall of the alcove has an eave. On the

right, the alcove is less than the 36" minimum, so the roof passes right over it.

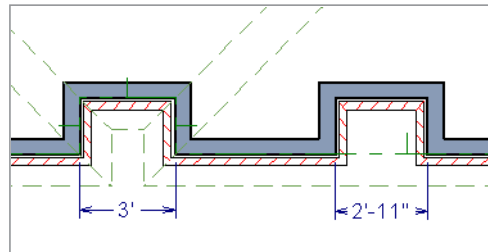

3 The **Roof Overhang** is measured horizontally from the exterior surface of the wall's framing layer to the end of the top of the rafter. It does not include gutters, sheathing or siding.

- **Normal** is the overhang at the eaves and is always the overhang for a roof plane having the default Pitch specified above. If the pitch for a particular roof plane is set differently, its overhang may try to maintain its fascia at the same height. Overhang can be greater for a shallower pitch, lesser for a greater pitch.
- **Gable** is the overhang dimension at gable ends or rake walls.

 If the roof overhang values are not sufficient to extend past the outer layer of exterior walls, the walls may not generate correctly in 3D views..

Materials Tab

The settings on this allow you to specify materials for the roof's various components. See "Materials Tab" on page 303.

Roof Styles Tab

The Roof Styles tab provides links to tutorial information about creating different roof styles automatically. Click on a roof style to launch the online Help to a page with information about the roof style you selected. See "Roof Tutorial" on page 61 of the User's Guide.

Editing Roofs

Unlike most other objects in Home Designer Essentials, roof planes cannot be selected and edited. To make changes to the roof, you must edit the edit roof directives in walls and/or settings in the **Build Roof** dialog, and then rebuild. See "Rebuilding Roofs" on page 192.

An exception to this rule is the **Material Painter**  tool, which you can use to change the materials used by individual roof planes without rebuilding the roof. Bear in mind, though, that any changes made using

the **Material Painter**  will not be retained if the roof is later rebuilt. See "The Material Painter" on page 301.

Deleting Roof Planes

There are several ways to delete roof planes.



Delete the entire roof quickly by selecting **Build> Roof> Delete Roof**.



You can also delete all roof planes at once in the **Delete Objects** dialog. See "Delete Objects Dialog" on page 93.

Gable Over Door/Window



The **Gable Over Door/Window** edit button allows you to add a small gable dormer over one or more selected doors or windows the next time automatic roof planes are built.

To use the Gable Over Door/Window tool

1. Select one or more doors or windows.

2. Click the **Gable Over Door/Window**  edit button.

- **Gable Over Door/Window**  is not available for openings placed in Full Gable Walls or for Bay, Box or Bow Windows. See "Bay, Box, Bow Windows & Roofs" on page 162.

3. The next time automatic roof planes are built, gables will be created over each of these doors and windows.
 - Each gable will extend 12" (300 mm) on either side of its door or window.
 - If two of these openings are within 30" (750 mm) of each other on the same wall, a single gable will be created.

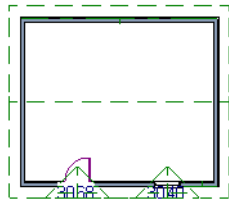

- If you move or resize the door or window(s), the associated Gable Line will not update until the roof is built again.
4. To remove a Gable Over Door/Window, select the door(s) or window(s) and click the **Delete Gable Over Opening**  edit button. The next time the roof is built, the gable will be removed.

Skylights



A skylight can be created by selecting **Build > Roof > Skylight** and drawing a rectangular polyline within a single roof plane. You can also simply click once within a roof plane to place a 2' x 2' skylight.

The **Skylight**  tool places a flat panel skylight into a roof hole, produces a hole in the ceiling platform below, and automatically

generates the skylight shaft between these two holes.

To place a skylight in a vaulted ceiling, uncheck **Ceiling Over This Room** in the **Room Specification** dialog, draw the ceiling planes to produce the vault and edit them as needed, and then draw the skylight. See "Structure Tab" on page 132.

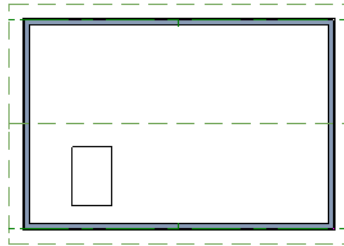

Skylights must always be contained by a single roof plane. If the roof plane is deleted, any skylights or holes it contains are also deleted. Aside from this restriction, skylights can be edited much like standard closed polylines. See “Editing Closed-Polyline Based Objects” on page 80.

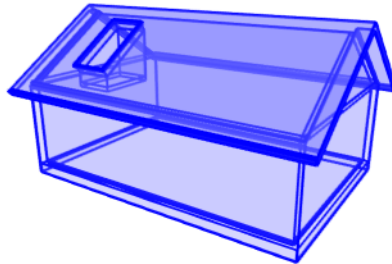

Editing Skylights

Once selected, skylights can be edited using the edit handles, edit toolbar buttons, or the **Roof Hole/Skylight Specification** dialog. See “Roof Hole/Skylight Specification Dialog” on page 196.

Roof Hole/Skylight Specification Dialog



Select a skylight and click the **Open Object** edit button to open the **Roof Hole/Skylight Specification** dialog. See “Skylights” on page 195.

General Tab

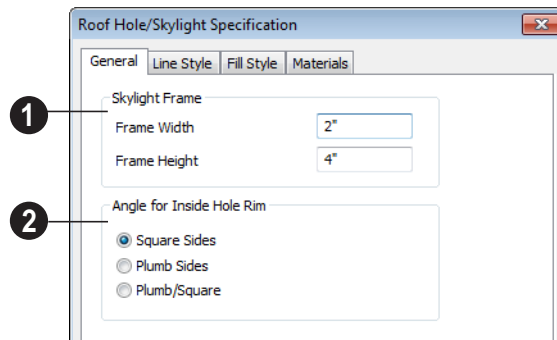

1 **Skylight Frame Width and Height** - Define the width and height of the frame or curb of the skylight.

2 **Angle for Inside Hole Rim** - Defines the shape of the skylight well where it passes through the roof plane.

- **Square Sides** - The framing for the skylight is cut square to the pitch of the roof.
- **Plumb Sides** - The framing for the skylight is plumb-cut.
- **Plumb/Square** - The bottom edge is plumb-cut, the top edge square-cut.

Line Style Tab

For information about the settings on this tab, see “Line Style Tab” on page 225.

Fill Style Tab

The settings on the Fill Style tab control the appearance of the selected skylight in floor plan view. For information about these settings, see “Fill Style Tab” on page 225.

Materials Tab

For information about the Materials tab, see “Materials Tab” on page 303.

Roof Pitches in Degrees

$$\angle^\circ = \frac{\text{rise}}{\text{run}}$$

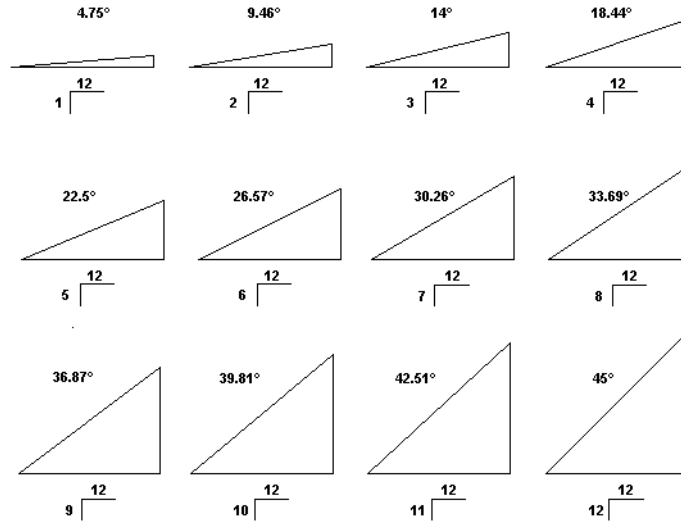

Stairs & Landings

Staircases can be composed of one or more straight or curved stair sections and landings. Stairs can be drawn, selected and edited in 2D and 3D views.

Stairwells can be created automatically or manually and can be seen in 3D views.



Local building and fire authorities must be consulted for specific stair construction codes and access requirements.

Chapter Contents

- Stair Defaults
- The Stair Tools
- Anatomy of a Staircase
- Drawing Stairs
- Displaying Stairs and Landings
- Editing Stairs
- Merging Stair Sections
- Landings
- Maintaining Tread Depth
- Starter Treads
- Wrapped Stairs
- Other Special Railings & Stairs
- Creating a Stairwell
- Rooms Below Staircases
- Staircase Specification Dialog
- Stair Landing Specification Dialog

Stair Defaults

The purpose of interior stairs is to provide passage from one floor platform to another, so the attributes that influence floor heights - including ceiling heights - also influence the

structure of stairs. When considering a staircase's structure, bear in mind that riser height is directly dependent on the distance from one floor platform to another.

The Stair Tools



Select **Build> Stairs** to access the Stair Tools.

Straight Stairs



To draw a straight staircase select **Build> Stairs> Straight Stairs**, then click and drag in floor plan or a 3D view. You can also click once to place a staircase that extends from the current floor up to the next floor. See "Drawing Stairs" on page 207.

Click Stairs



Select **Build> Stairs> Click Stairs** to create stairs between levels on the same floor with a single click of the mouse. Click the low side, within a few feet of where the floor changes height.

- If you click on the low side of a floor platform defined by a railing, a doorway will be created in the railing, adjacent to the stairs.
- If you click on the low side of a floor platform defined by a wall, stairs will be created but a doorway will not.

- If you click at a location that is not near the edge of a floor platform, a full height staircase will be created.

Curved Stairs



Select **Build> Stairs> Curve to Left** or **Curve to Right** and click once in floor plan view to place a curved staircase. See "Curved Stairs" on page 207.

Landing



Select **Build> Stairs> Landing** to draw a landing, which is a platform connecting two or more stair sections. See "Landings" on page 211.

There are two ways to create a landing using this tool:

- Click once to place a landing measuring 39" (975 mm) on each side.
- Click and drag from end to end to draw a rectangular landing sized as needed. See "Polylines" on page 15.

Anatomy of a Staircase

Stairs are often described in terms of **rise** and **run**. Rise is typically between 6" and 8", and the run between 10" and 12". In metric plans, rise is 177 to 190 mm, and the run is about 250 mm.

Staircase Terminology

Balusters - The vertical members that run between the handrail and the treads or bottom rail.

Bracket - Decorative L-shaped supports on the exposed side of stairs below each tread.

Landing - A platform connecting two or more stair sections.

Newels - The end post of a stair railing located at landings and the beginnings and endings of new stair sections.

Rise - The height of a riser, measured from tread surface to tread surface, Also referred to as Unit Rise.

Rise Angle - The angle of the staircase or stair section, defined by a line drawn through the back surfaces of its treads.

Riser - The vertical stair member located between the treads. Risers may be solid or open. When open, the front surfaces of the stringers are considered the risers.

Run - The depth of a tread, measured from riser surface to riser surface. Run does not include the Tread Overhang. Also referred to as Unit Run.

Runner - The carpet that runs down the center of the staircase.

Shoe - The bottom railing, placed on the landing floor, that anchors the balusters at landings.

Stringer - The inclined support member of a staircase that supports the treads and risers.

Tread - The horizontal member of a stair that the foot is placed on.

Tread Overhang - The portion of a tread extending past the front surface of the riser and over the tread below. Also referred to as Nosing or Nosing Extension, it is not included in the Run or Tread Depth measurements.

Thread Thickness - The vertical depth of the tread material.

Stair Structure and the Model

Stairs locate the height of the floor platform that they are drawn on, and seek the next level, which may be the floor platform of the floor above or a landing. The stringers locate the subfloor of the floor platforms and maintain consistent riser height. If the stairs are long enough to reach the next level at a reasonable rise angle, their tread depth and number of treads are automatically calculated to create a staircase with consistent tread and riser dimensions along its entire length.

Stair Sections and Subsections

In Home Designer Essentials, staircases can be composed of multiple sections and subsections. See "Merging Stair Sections" on page 209.

- Stair sections are separated by landings.
- Subsections are considered part of the same section because they are connected

to one another directly rather than separated by a landing.

Drawing Stairs

Stairs can be drawn in floor plan and 3D views but not in elevation views. In 3D views, these objects can only be drawn in the presence of a floor platform or terrain perimeter. See “Working in 3D” on page 331.

There are a few things to keep in mind when drawing stairs.

- Before stairs are created, make sure that the heights for both the lower and upper floors are correctly defined.
- Stairs are drawn going **UP**, so they should be drawn from the lower of the two floors they connect.
- By default, stairs adjust their riser and tread dimensions to connect two floor heights if possible. The rise and run are calculated so that the steps are consistent in size.
- If you have the **Reference Display**  turned on, stairs snap to the reference display.
- If a stairwell room has been defined on the floor above, the top of the stairs can be dragged until it stops at the railing or wall defining the stairwell.

Straight Stairs

Straight Stairs  can be created in three different ways:

- Click and drag in a straight line to draw stairs that are the length that you drag,

- Click once to place stairs that go from the current floor up to the height of the next floor level.
- Click once using the **Click Stairs**  tool to create stairs between rooms on the same floor with different floor heights or between exterior rooms and the terrain.

An individual stair section must be between 6” (150 mm) and 100’ (30,000 mm) in length. If a greater length is needed, connect two sections using a landing.

Curved Stairs

 **Curved Stairs** can be created in floor plan view by selecting **Build > Stairs > Curve to Left** or **Curve to Right**. Click to place a 90° curved stair section that can then be edited. You can continue clicking to place additional curved staircases until another tool is selected.

- In addition, you can change a straight stair section into curved stairs, or vice versa by selecting the stairs and clicking the **Change Line/Arc**  edit button. See “Change Line/Arc” on page 92.

Drawing Stairs Downward

Stairs can be drawn from the current floor level downward; however, drawing stairs between floors in this manner is not recommended. Drawing downward should

only be used to create a staircase between a porch or deck and the terrain when you require the direction arrow to say “DN” instead of “UP”.

To draw stairs going downward

1. Select **Build> Stairs> Straight Stairs** .
2. Hold down the Alt key or the right mouse button.

3. Click and drag to create straight stairs.

When drawing stairs from a floor platform to the terrain, or vice versa, they will locate the height of the terrain as long as it is lower than the floor height. You can also create “room” outside the structure and use it to establish the bottom height of the stairs. Then, draw in an upward direction from the lower platform to the upper platform.

Displaying Stairs and Landings



The display of stairs and landings in all views is controlled in the **Display Options** dialog. Stairs and landings are placed on the “Stairs & Ramps” layer. See “Displaying Objects” on page 59.

In Floor Plan View

In floor plan view, stairs and landings display on the floor they were drawn on and are only visible from the floor above if there is a stairwell.

Stairs have an arrow indicating the direction they run. Interior stairs have an **UP** arrow on the floor they were created on and a **DN** arrow when viewed from the floor above. See “Drawing Stairs” on page 207.

The style and size of a direction arrow can be specified in the **Staircase or Ramp Specification** dialog. The color and display are controlled by the “Stairs & Ramps, Up/Down Arrows” layer.

When a staircase is selected in floor plan view, the numbers associated with each of its sections and subsections display. Stair

sections are assigned a single-digit number. Subsection numbers have two parts: a section number and subsection number, separated by a hyphen.

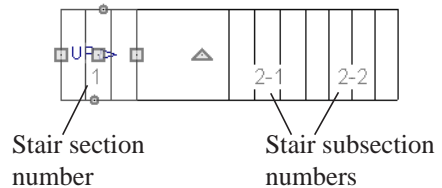

In 3D Views

Although stairs span between two floors, they can only belong to one floor. As a result, only multi-floor views show the upper floor with the platform opening and the lower floor with the staircase simultaneously. In Doll House Views, stairwells may appear as an empty spaces. See “3D View Tools” on page 320.

Editing Stairs

Staircases can be selected and edited in floor plan view and 3D views. See “Selecting Objects” on page 71.

Using the Mouse

When a staircase is selected, its edit handles display. These edit handles can be used to customize the object in many ways. See “Editing Objects” on page 70.

- Straight stair sections are edited like lines. They have additional edit handles for resizing the width of the section. See “Editing Line Based Objects” on page 73.
- Curved stair sections are edited like arcs and also include edit handles for resizing the stair’s width. See “Editing Arc Based Objects” on page 75.
- When stair sections are merged, the edit handles display differently depending on

what subsection is currently selected. See “Merging Stair Sections” on page 209.

- When moving merged stair sections, all merged sections move as one.
- Additional edit handles display on the first two treads of a staircase if the

Starter Tread  edit button is clicked. See “Starter Treads” on page 212.

In the Specification Dialog

 Stairs can be customized in the **Staircase Specification** dialog. See “Staircase Specification Dialog” on page 217.

Using the Edit Tools

A selected staircase can be edited in a variety of ways using the buttons on the edit toolbar. See “The Edit Toolbar” on page 21.

Merging Stair Sections

Any combination of straight and curved stair sections using **Automatic Heights** can be merged. The resulting staircase section is made up of subsections and, if there are no landings, functions as a single unit.

Stair subsections must be drawn in the same direction if they are to be merged:

- The top edge of a stair section cannot merge with the bottom edge of another section.
- Combinations of stairs drawn in the **UP** and **DOWN** directions cannot be merged.

Stair subsections merge at the center points of their upper and lower edges.

To merge stair sections

1. Confirm that the stairs that you wish to merge are using **Automatic Heights**. See “General Tab” on page 218.
2. Position the sections so they are in the desired relationship to each other.
 - In order to merge stair sections correctly, they must be parallel to one another.

- To create merged subsections that change direction, make one of the merged sections curved.
3. Select either stair section so that its edit handles display.
 4. Click the Extend handle on the end to be merged and drag it to the point where the two stairs are to meet.

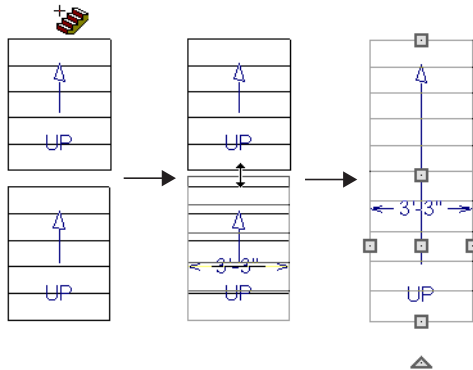

Merging parallel stair sections

A staircase consisting of merged subsections resembles a single stair section in floor plan view. The UP (or DN) arrows join, becoming a single direction arrow.

When a subsection is selected, the entire staircase is selected. Additional edit handles, indicating the presence of multiple subsections and allowing you to reposition the line along which they join. See “Using the Mouse” on page 209.

Curved Subsections

Stair subsections attached at both ends by other sections do not have a free end that can be dragged into a curve. In this situation, change the middle sub-section to a curve

using the **Change Line/Arc**  edit button. See “Change Line/Arc” on page 92.

To curve an enclosed stair subsection

1. Draw three straight stair sections and connect them end to end.
2. Select the middle subsection.

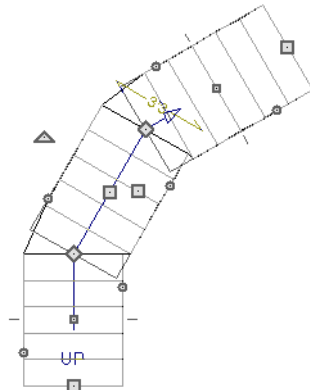

Select the middle stair subsection

3. Click the **Change Line/Arc**  edit button. The center section turns into a curved stair section.

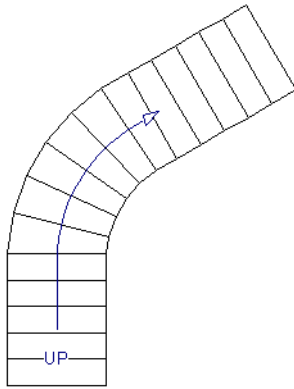



After using Change Line/Arc

4. Use the triangular Change Curve edit handle to adjust the curvature of the middle section as needed.

Landings

Stair landings are platforms between stair sections and can be created in either of two ways:

- Using the **Landing**  tool.
- By clicking between two stair sections using the **Straight Stairs**  tool.

To create a landing between stair sections:

1. Draw two stair sections going UP. They can be at any angle.
2. Click between the two sections using the **Straight Stairs**  tool to create a landing. Notice that only one direction arrow displays after the sections are joined by a landing.

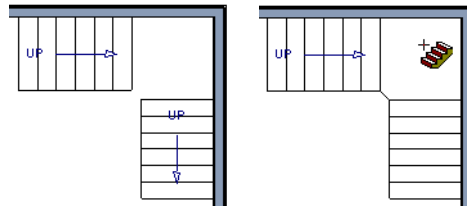

Creating a stair landing

Multiple stair sections can be connected to one landing. For example, two or three stair sections might meet at a landing with a single stair section continuing to the next level.

To be linked by a landing, all sections must be drawn in the same **UP** direction and the top of one section should be near the bottom of the next.

Stair sections connected with a landing will move together as a single unit.

A landing formed between two stair sections having less than a 90° angle between them

are created with a short edge not less than 6" (150 mm). This is because most building codes require the shortest tread to be at least 6" wide. This edge can be manually edited to less than 6" if needed.

Editing Landings

Landings can be selected in 2D and 3D views, both individually and in groups, and edited using the edit handles, the edit toolbar, and the **Landing Specification** dialog. See "Stair Landing Specification Dialog" on page 222.

Landings derive their initial materials and railing characteristics from the stairs attached to them. You can assign a unique material to a landing in its specification dialog or using the **Material Painter** ; however, the railing style is always defined by the attached stairs.

Custom Shaped Landings

Landings can be edited like other closed polyline-based objects. You can add or remove edges, convert an edge from straight to curved, or vice versa. A curved landing creates curved railings. See "Editing Closed-Polyline Based Objects" on page 80.

You can edit the shape of a landing into a wide variety of shapes. So that the railings of stair sections connect properly to the landing railings, make sure that each stair section end is snapped to a landing edge with the same length as the stair's width. If necessary, use

the **Break Line**  tool to create a break in a landing edge if it is longer than the connecting stairs are wide. See "Break Line" on page 92.

Landing Height

A landing's height is controlled by the program and will adjust automatically as the stairs attached to it are modified so that the stairs maintain a consistent rise angle.

Maintaining Tread Depth

Most building codes require staircases to maintain a consistent tread depth.

Home Designer Essentials measures a stair section's length and tread depth along a Walk Line located 12" (30 cm) from the right edge of the stair section. On curved stairs, it is located 12" (30 cm) from the inside edge of the curve.

When a curved stair section has **Automatic Treads** specified in the **Staircase Specification** dialog and the Walk Line is

used, the number and/or width of treads in a section or subsection changes when the inner edge is moved. For this reason, it is best to finalize stair section width as early as possible.

Starter Treads



The first and second treads of a staircase can be turned into starter treads by clicking the **Starter Tread** edit button. Starter treads extend to the side of the staircase, have rounded edges and are common on traditional staircases.

A starter tread can be added only to open sides of a stair section. If one side of a stair section is against a wall or wrapped (see “Wrapped Stairs” on page 213), only the exposed tread end can become a starter tread.



To create starter treads

1. Click on a staircase to select it.
2. Click the **Starter Tread**  edit button. An edit handle displays on each end of both the first and second treads.

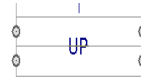

3. Drag either of the handles on the first tread outward from the stair section. If the stair section is against a wall, only one handle displays on the side opposite the wall.
4. As you drag, the ends of the tread become rounded.

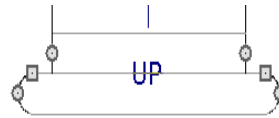

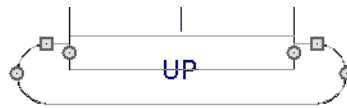

5. Two additional edit handles display on each side of the tread, along the back edge.
6. Drag either of the two square handles upward to increase the width of the rounded ends of the tread.

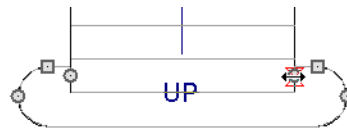

7. Drag the edit handle on the second tread outward from the stair section to create a second starter tread.



8. To make changes to existing starter treads, select the stairs, click the **Starter Tread**  edit button and repeat the above steps as needed.
9. When you are finished editing the starter treads, click the **Main Edit Mode**  to restore the stairs' regular edit handles and toolbar buttons.

Wrapped Stairs

Stairs can be wrapped around the corner of a deck or landing. Curved stairs and stairs with multiple subsections cannot be wrapped. See “Style Tab” on page 220.

To wrap stairs around a deck

1. Draw a deck if you have not already done so. See “Decks” on page 127.
2. Use the **Click Stairs**  tool to draw a stair section on each side of the corner around which you want them to wrap.
3. Draw a second set of stairs on the other edge of the deck the same way.
4. If necessary, move the stair sections toward the corner of the deck. The two sections merge to form wrapped steps.



You can also draw stairs down from a deck by right-clicking to draw them or by pressing the Alt key while you drag. See “To draw stairs going downward” on page 208.



To wrap stairs around a landing

1. Draw two perpendicular **Straight Stair**  sections.
2. Click between them to create a landing.
3. Rotate one stair section 180°.

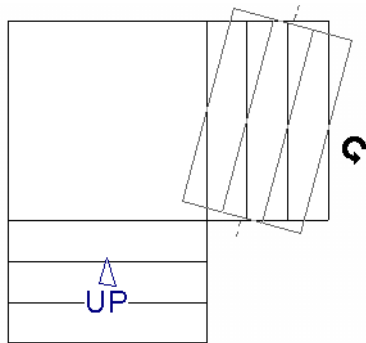

4. The stairs wrap around the corner. Notice that the Up arrow displays on the most recently edited stair section.

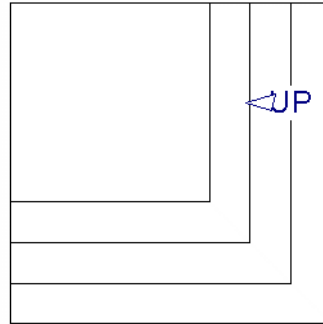

Other Special Railings & Stairs

Stairs can be customized to meet a variety of needs.

Solid Railings

To create a solid rail along a staircase, create the Railing against, but not underneath, the stairs and specify it as Solid. See “Rail Style Tab” on page 117.

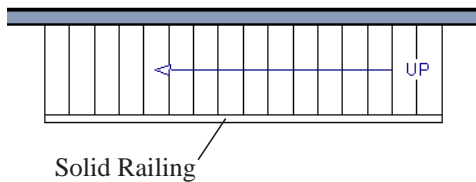

The solid railing recognizes the adjacent stairs and climbs alongside them.



If any balusters show beyond the railing, eliminate them by unchecking **Left railing** or **Right railing** in the **Staircase Specification** dialog. See “Style Tab” on page 220.

Creating a Stairwell

An interior staircase must be located in a stairwell, an opening to the floor above. A

stairwell is an Open Below room type on the floor above. See “Room Types” on page 124.

If you create a stairwell away from other walls so the Open Below is created in the center of another room, connect a wall of the Open Below room to another wall using an invisible wall.

Creating a Stairwell Automatically





To create a stairwell that matches the perimeter of a selected staircase, click the **Auto Stairwell** edit button. This button is only available when a living space exists above the staircase. It will not be available if the space above is Open Below or on the Attic Floor.

Auto Stairwell  automatically creates a room on the floor above enclosed by railings, defined as **Open Below** in the **Room Specification** dialog, and given a **Stairwell** room label. This room can be selected and edited like any other room.

Creating a Stairwell Manually



Stairwells can also be created manually.

To create a manual stairwell

1. Draw a two-story building. Create the staircase on the first floor.
2. Make the second floor the **Current Floor** and the first floor the **Reference Floor**. See “The Reference Floor” on page 176.
3. Select **Tools> Reference Floors> Reference Display**  to show the Reference Floor, including the stairs.
4. On the upper floor, use the **Railing**  tool to create a room around the stairs.

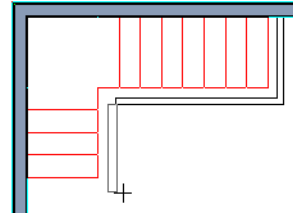
Use the edit handles to position the railings as needed.



5. Select the railings one at a time and move them into position.
 - When a railing is selected, its bounding box shows the location of the outer surface of the railing’s drywall layer. For best results, this outer surface (which does not display when the railing is not selected) should meet the top edge of the stairs.
 - If you prefer, you can also go **Down One Floor** and adjust the top edge of the staircase to snap it to the surface of the railing on the floor above.
6. When the railings are positioned properly, select **Tools> Reference Floors> Reference Display**  to turn off the display of the Reference Floor.
7. Click inside the room using the **Select Objects**  tool to select it, then click the **Open Object**  edit button.
8. On the General tab of the **Room Specification** dialog, select “Open Below” from the **Room Type** list. Click **OK** to close the dialog.

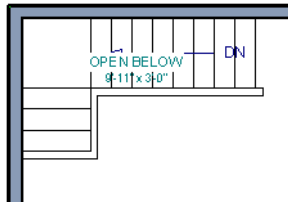

9. Place a **Doorway**  in the railing at the top step for an opening.
10. Select the doorway and define a large width in the **Door Specification** dialog.

If the doorway is specified wider than the railing, its width maximizes to fit the space available.



Rooms Below Staircases

Rooms such as closets or storage areas are commonly located beneath staircases.

To create a room below a staircase

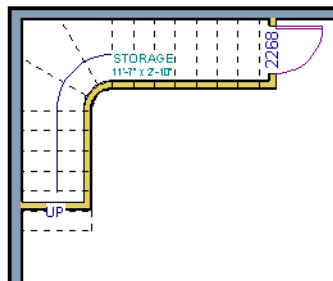

1. Draw a staircase, select it, and click the **Open Object**  edit button to open the **Staircase Specification** dialog.
 - On the Fill Style tab, select None (Transparent) so the walls and other objects under the stairs can be seen.

2. On the same floor as the staircase, draw the **Interior Walls**  under them, following their shape.
3. Reposition the walls as needed, making sure that each is entirely under the stairs.
4. The wall at the foot of the stairs should be placed no closer to the bottom than the second step.
5. Add a door and specify the Room Type.



Staircase Specification Dialog

 Staircases can be defined with the greatest accuracy using the **Staircase Specification** dialog. To open the **Staircase Specification** dialog, select a stair section and click the **Open Object** edit button or double-click a stair section using the

Straight Stairs  or **Select Objects**  tool.

If a staircase is composed of multiple stair sections, the section that you clicked on to select the staircase is the Selected Section; however, information about all the sections is available and can be edited in this dialog.

 It is recommended that all floor heights, ceiling heights and platform thicknesses be established before using the Staircase Specification dialog.

General Tab

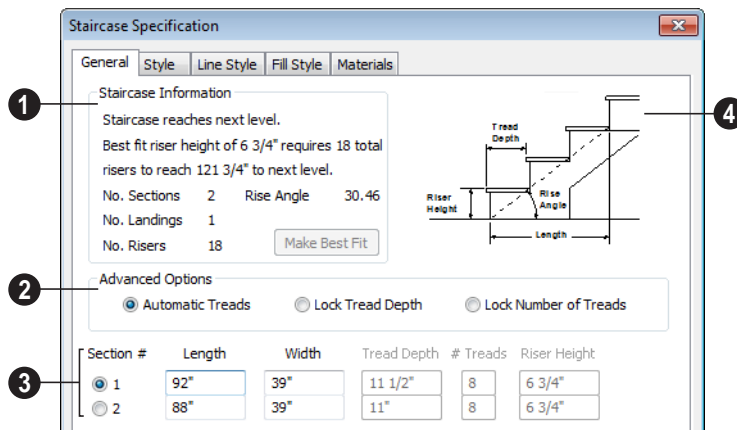

1 Staircase Information - Structural information about the selected staircase displays here. This information cannot be edited directly, but updates as changes are made in the dialog. If you modify a value elsewhere, press the **Tab** key to update this information.

- The first comment tells whether or not the staircase reaches the next level. It also indicates whether its rise angle is either steeper or more shallow than the Best Fit,

described below. If **Automatic Heights** is unchecked, this comment instead says "Start and end heights are set manually".

- The second comment, **Best fit riser height of ___ requires ___ total risers to reach ___ to next level**, describes the ideal rise and run for the selected staircase. The program defines the Best Fit Riser Height as the riser height closest to 6 3/4" (168.75 mm) that allows the selected staircase to meet the next level

precisely. This comment is only active if **Automatic Heights** is checked, below.

- The total number of stair **Sections**, **Landings**, and **Risers** associated with the selected staircase also display here.
- The **Rise Angle** of the currently active stair section also displays here.
- Click the **Make Best Fit** button to add or remove risers to the Selected Section. Only available when **Automatic Heights** is checked and the staircase does not currently use the Best Fit Riser Height.

Make Best Fit will also extend stairs drawn in a downward direction until they reach the terrain. See “Terrain Perimeter” on page 258.

- 2 The **Advanced Options** apply to all sections and subsections.

Automatic Treads, Lock Tread Depth, and Lock Number of Treads affect how treads are calculated. Only one of these options can be selected at a time.

- Select **Automatic Treads** to have the program define the depth and number of stair treads. If the staircase has multiple sections, each may have different tread depths.
- Select **Lock Tread Depth** to specify the Tread Depth for each stair section, below, and prevent them from changing. When Lock Tread Depth is selected and the length of the stairs is changed, the number of treads will change.
- Select **Lock Number of Treads** to specify the number of treads in each stair section and prevent it from changing. When Lock Number of Treads is selected and the length of the stairs is changed, the tread depths will change.

- Uncheck **Automatic Heights** if you would like to specify the bottom and top heights of each stair section, as measured from the default floor height of Floor 1, 0” (mm). When checked, the program automatically defines the top and bottom heights by precisely locating floor platforms and landings.

Lock Bottom and Lock Top are actions rather than settings. If you make changes to the staircase that will affect its length, first lock either the bottom or top end of the Selected Section to prevent it from moving. The height of the Selected Section’s locked end is not affected by these settings - only its position on the X/Y axis.

- Select **Lock Bottom** to lock the position of the selected stair section’s bottom end to prevent it from moving. Sections and landings below the selected section do not move when you click OK, while those above do move.
- Select **Lock Top** to lock the position of the selected stair section’s top end to prevent it from moving. Sections and landings above the selected section do not move when you click OK, while those below do move.

 If you select a staircase by clicking near its bottom end, Lock Top will be selected; if you select it near its top end, Lock Bottom will be selected.

- 3 The specifications for each stair section and subsection display and can be edited here. A maximum of ten items can display.

A change in one value usually affects other values. You may need to reposition the staircase after making changes.

- The **Section #** column identifies the Selected Section and the number of each section of the selected staircase. The radio button to the left indicates which section or subsection is selected. See “Displaying Stairs and Landings” on page 208.
- Define the **Length**, or run, of each section.

When the length of a section changes, other sections and landings in the staircase unit move in response. You can specify whether the bottom or top edge of the Selected Section moves when you resize it by selecting either the Lock Bottom or Lock Top radio button, above.

- Define the **Width** of each section. If a section is connected to a landing, its width should equal the length of the landing edge that it connects to. See “Landings” on page 211.

- Specify the **Tread Depth**, or run, of each stair tread in the selected section.
 - Define the number of **Treads** in a stair section or subsection.
 - Define the **Bottom Height**, the height of the stair section’s bottom edge. To lock this value, click the radio button to the left of the section’s number, then click the Lock Bottom radio button, above, and click OK.
 - Define the **Top Height**, the height of the stair section’s top edge. To lock this value, click the radio button to the left of the section’s number, then click the Lock Top radio button, above, and click OK.
 - Define the **Riser Height**, the height of the risers in each stair section.
- 4 A diagram of a sample staircase’s structure displays here for reference.

Style Tab

The settings on the Style tab affect all stair sections and subsections.

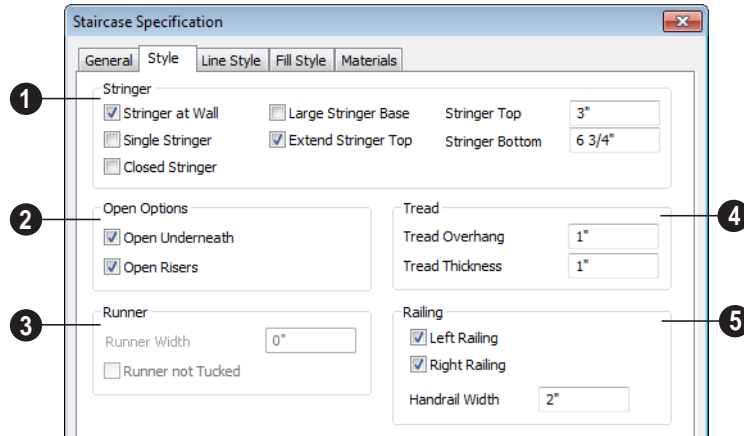

1 Specify the attributes of the selected staircase's **Stringers**, which are the angled support members that support the treads. See "Anatomy of a Staircase" on page 206.

- Check **Stringer at Wall** to produce a raised stringer top baseboard at the sides of the stair sections against walls. This baseboard follows the slope of the stair.
- Check **Single Stringer** to form a single 5-inch (125 mm) thick stringer in the center of the staircase.

Checking **Single Stringer** automatically checks **Open Risers** and unchecks **Stringer at Wall** and **Closed Stringer**. You may want to increase the tread thickness when this is checked.

- Check **Closed Stringer** to raise the tops of the exposed stringers to cover the sides of the treads. If this is checked, no central stringer is applied to open riser stairs.

This setting only affects those stringers that are not against a wall.

- Check **Large Stringer Base** to widen the stringers at the foot of the staircase. This is helpful when walls are created below the stairs.

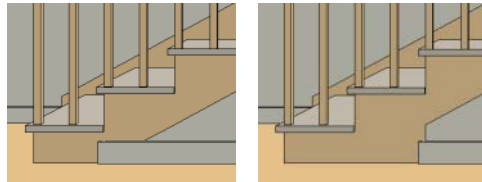

Large Stringer Base shown at right

- **Extend Stringer Top** is checked by default and extends a triangular portion of the stringer under the landing or platform at the top of the stairs.
- Specify the height of the **Stringer Top** when **Stringer at Wall** or **Closed Stringer** is selected. This is measured

along the plane of the riser face from the top of a tread to the top of the stringer. It cannot be less than 2 inches (5 cm).

- Specify the height of the **Stringer Bottom**. This is measured from the top back corner of a tread down to the bottom edge of the stringer. It must be equal to or greater than the riser height.

2 **The Open Options** control whether the selected stairs have open risers or an open underside.

- Uncheck **Open Underneath** to add a skirt below the staircase along the two sides. It looks like a wall in 3D, but it has only a single face. Base molding does not generate along the bottom of the skirt, and doors cannot be placed in it.

In most cases, the recommended way to enclose the area beneath stairs is to use walls. See “Rooms Below Staircases” on page 216.

- Check **Open Risers** to eliminate the riser face under each tread and expose the stringers. If **Closed Sides** is also selected, no central stringer is supplied.

3 Specify the attributes of the staircase’s carpet **Runner**. Only available when **Open Risers** is unchecked, above.

- Specify the **Runner Width**. The default value of 0 does not create a runner. Only available when **Open Risers** is unchecked, above.
- Check **Runner not Tucked** to have the runner drop straight down from the tread front to the riser below. This is unchecked by default.

4 Specify the characteristics of the staircase **Treads**. See “Anatomy of a Staircase” on page 206.

- Specify the **Tread Overhang**, which is the distance that each tread overhangs the riser.

- Specify the **Tread Thickness**.

5 **Railing** specifications.

- Check **Left Railing** and/or **Right Railing** to specify the placement of railings on stair sections.
- **Handrail Width** defines the horizontal width of the handrail used by the selected staircase and any attached landings.

Line Style Tab

The settings on the Line Style tab are available for a variety of other objects in the program. For information about these settings, see “Line Style Tab” on page 225.

Fill Style Tab

The settings on the Fill Style tab affect the appearance of the selected staircase in floor plan view. For information about these settings, see “Fill Style Tab” on page 225.

Materials Tab

The settings on the Materials tab affect the appearance of the selected staircase in 3D views and are available for a variety of objects throughout the program. For information about these settings, see “Materials Tab” on page 303.

The settings on this tab will also affect the materials applied to any landings attached to the selected staircase. See “Landings” on page 211.

Stair Landing Specification Dialog



Select a landing and click the **Open Object** edit button to open the **Stair Landing Specification** dialog. See “Landings” on page 211.

The tabs in this dialog are found in the specification dialogs for a variety of different objects in the program.

Polyline Tab

The Polyline tab indicates the length of the landing’s **Perimeter**, its enclosed **Area**, and its **Volume**.

The settings on the this tab are available for a variety of other objects in the program.

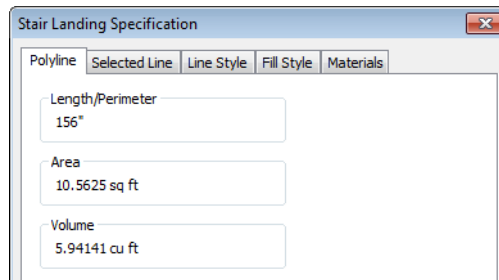

Selected Line Tab

The Selected Line tab is available when the selected edge is a line as opposed to an arc. See “Selected Edge” on page 71.

The settings on this tab are available for a variety of other objects in the program.

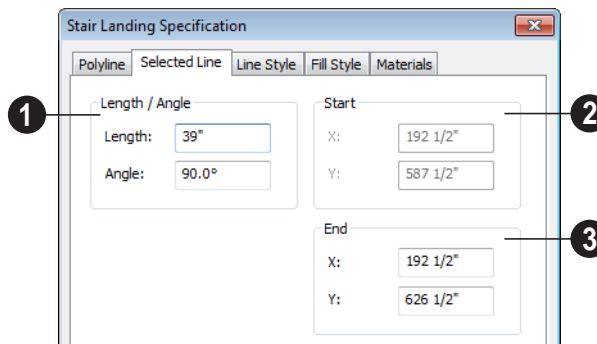

1 Specify the **Length** and **Angle** of the selected line.

2 The X and Y coordinates for the **Start** point of the line display here.

- 3 Specify the X and Y coordinate for the **End** of the line here.

Moving the End of a line segment moves the start of the next connected line.

Selected Arc Tab

The Selected Arc tab is available only when the selected edge has been converted to an arc. See “Change Line/Arc” on page 92.

The settings on this tab are available for a variety of other objects in the program.

The screenshot shows the 'Stair Landing Specification' dialog box with the 'Selected Arc' tab selected. The dialog is divided into four main sections, each indicated by a numbered callout:

- 1 Arc:** Center X: 231 1/2", Center Y: 607", Radius: 43 5/8", Start Angle: 206.565051°, End Angle: 153.434949°, Arc Angle: -53.130102°, Arc Length: 40 7/16".
- 2 Start:** Start X: 192 1/2", Start Y: 587 1/2", Start Direction: 116.565051°.
- 3 End:** End X: 192 1/2", End Y: 626 1/2", End Direction: -116.565051°.
- 4 Chord:** Chord Length: 39", Chord Angle: 90.0°.

At the bottom of the dialog are 'OK', 'Cancel', and 'Help' buttons.

- 1 **Arc** - These settings define the arc.
- **Center X** - The x coordinate for the center of the arc displays here for reference.
 - **Center Y** - The y coordinate for the center of the arc displays here for reference.
 - **Radius** - Specify the distance between the center of the arc and the arc surface.
 - **Start Angle** - The angle of a line drawn from the arc center to the arc start displays here for reference.

- **End Angle** - Specify the angle of a line drawn from the arc center to the arc end.
 - **Arc Angle** - Specify the angle between the center of the arc and each end.
 - **Arc Length** - Specify the length of the arc along the curve.
- 2 **Start** - Information about the starting point of the selected arc displays here.
- **Start X** - The X coordinate of the arc's starting point displays here.
 - **Start Y** - The Y coordinate of the arc's starting point displays here.

- **Start Direction** - Specify the angle of a tangent line at the start of the arc.
- **End Direction** - The angle of a tangent line at the end of the arc displays here.
- **End** - Information about the end point of the selected arc displays here.
- **End X** - Specify the X coordinate for the end of the arc.
- **End Y** - Specify the Y coordinate for the end of the arc.
- **Chord** - Define the selected arc's chord, which is the line drawn between its start and end points.
- **Chord Length** - The straight line distance between the two ends of the arc.
- **Chord Angle** - Specify the angle of the chord.

Line Style Tab

The settings on the Line Style tab are available for a variety of objects throughout the program.

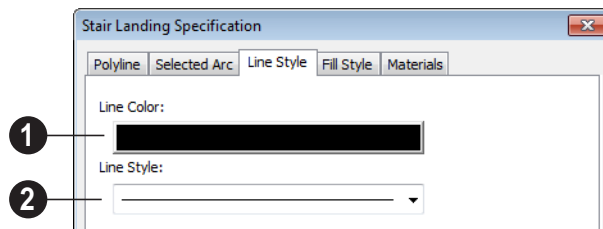

- 1 Click the color bar and specify the **Line Color** used to represent the selected object. See “Color Chooser Dialog” on page 309.
- 2 Select a **Line Style** to represent the selected object from the drop-down list.

Fill Style Tab

The settings on the Fill Style tab affect the appearance of the selected landing in floor plan view.

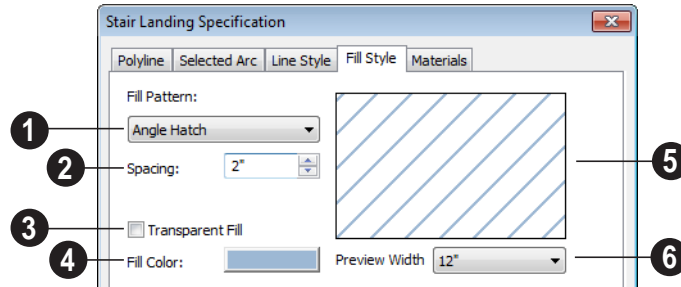

- 1 Choose a **Fill Pattern** from the drop-down list.

The options that follow are disabled until you select a pattern other than **None** from the **Fill Pattern** drop-down list.

- 2 Define the **Spacing** for the selected fill pattern.
- 3 Check **Transparent Pattern Fill** to make the fill pattern transparent. When you check this option, any objects behind the fill pattern are visible through it.

- 4 **Fill Pattern Color** - Select a line color or fill color if a solid fill is specified. This overrides the layer color. See “Color Chooser Dialog” on page 309.

- 5 A preview of the selected pattern displays here. As changes are made to the settings on this tab, the preview will update.

- 6 Choose a **Preview Width** from the drop-down list. This value controls how large an area the preview represents. The selected value indicates the length of each side of the preview in actual plan inches (mm).

Materials Tab

When a landing is attached to stairs, its initial materials are derived from the stairs.

The settings on this are available for a variety of objects throughout the program. For information about these settings, see “Materials Tab” on page 303.

Electrical

The electrical plan shows the location of all electrical objects such as lights, switches, outlets, smoke detectors and vent fans. Basic wiring diagrams show which objects share circuits and the locations of the controlling switches.

Electrical objects can be displayed in 2D and 3D views. Some electrical light fixtures also add light sources to 3D views. See “Lighting” on page 337.

Usually, the electrical plan is one of the last additions to a plan since the position of most electrical objects is determined by the location of walls, cabinets and other objects.



Building requirements vary throughout the country and around the world. It is your responsibility to comply with local codes.

Chapter Contents

- The Electrical Tools
- Creating Wiring Schematics
- Auto Place Outlets
- Electrical Library
- Displaying Electrical Objects
- Editing Electrical Objects
- Electrical Service Specification Dialog

The Electrical Tools



Select **Build> Electrical** to access the Electrical Tools.

Click in floor plan view to place an electrical object. Some can only be placed against walls, some only on the ceiling or floor, and some automatically change as needed. If you click within 12" of the wall, the selected object is placed on the wall.

Once an electrical object has been placed, it can be edited in the **Electrical Service Specification** dialog. See “Electrical Service Specification Dialog” on page 232.

Outlets



Select **Build> Electrical> 110V Outlet** to place 110 volt duplex outlets in walls or on the floor. Select **Build> Electrical> 220V Outlet** to place 220 volt outlets.

Certain room types and situations cause various types of outlets to be placed. For example:

- In rooms defined as Kitchen, Bath or Master Bath, Ground Fault Circuit Interrupt (GFCI) outlets are placed.



If standard outlets are placed in a room prior to defining it as a Kitchen or Bath, you should replace them with GFCI outlets.

- Outlets placed on the wall behind a base cabinet containing a dishwasher or sink are placed at the normal 12" (300 mm) above the floor. If an outlet is placed

above a cabinet, the default Above Cabinet Default Height is used instead.

- Outlets placed outside the building or in an exterior area such as a deck or porch are labeled WP, or Water Proof.

To take advantage of the program’s capabilities, define room types properly before placing electrical objects. See “Room Types” on page 124.

Light Fixtures



Select **Build> Electrical> Light** to place light fixtures. All light fixtures placed in a plan can also serve as light sources in 3D views. To place a light fixture using the Light tool

- Click near a wall to place a wall-mounted fixture at that location.
- Click away from a wall to place a ceiling mounted light.
- Some light symbols from the library can be mounted under wall cabinets, as well.

Switches



Select **Build> Electrical> Switch** to place electrical switches as specified in the **Electrical Defaults** dialog. Like outlets, the height of switches is measured from the floor to the center of the object.

An electrical switch can be placed on either a wall or a cabinet, depending on the type of switch. A selection of each type is available in the Library Browser. See “Placing Library Objects” on page 293.



If you connect two or more switches in a circuit, they update to 3-way or 4-way switches automatically.

Lighting and Electrical Libraries



A selection of free-standing and ceiling-, wall- and cabinet-mounted

light fixtures is available in the Library Browser at Home Designer Core Catalogs> Architectural> Lighting.

Special use outlets, switches, jacks and numerous other electrical items can be found at Home Designer Core Catalogs>Architectural> Electrical. See “The Library” on page 282.

Creating Wiring Schematics

Connect Electrical



Select **Build> Electrical> Connect Electrical** to illustrate circuits. Using this tool, you can show which lights and outlets are attached to any given switch.

To create a new circuit or to add to an existing circuit, click one electrical object while using **Connect Electrical**  tool, drag to the next object and release.

Remove an electrical object from a circuit by selecting it and clicking the **Delete**  edit button. See “Deleting Objects” on page 93.

More than one switch can control an object or group of objects. Two switches controlling the same objects are referred to as three-way switches. Three switches controlling the same objects are called four-way switches. The number of “ways” is one more than the number of switches in the same circuit. This number displays with the switch symbol in floor plan view.

Auto Place Outlets







Select **Build> Electrical> Auto Place Outlets** and click in a room tool to place outlets, usually 110 volt, around the entire room at intervals not greater than twelve feet so that no wall position is farther than six feet (1800mm) from the nearest outlet.

It is important that the room type be defined before using **Auto Place Outlets**  so that outlets are placed appropriately in each room

type. For example, GFCI (Ground Fault Circuit Interrupter) outlets are placed over cabinets in Kitchen, Bath and Master Bath rooms

Stand-alone or built-in appliances such as ranges, washers, and dryers each have their required 110 volt or 220 volt outlets placed automatically. Lights are always placed above sinks.

Auto Place Outlets  requires a room to have a door before outlets are automatically placed and does not work in any room defined as an exterior room. Exterior rooms require that the outlets be placed individually using the **110V Outlets**  tool or from the Electrical Library. See “Room Types” on page 124.

Railings and invisible walls do not separate rooms for **Auto Place Outlets** . If **Auto Place Outlets**  is used in a room defined by railings or invisible walls, outlets are automatically placed in all adjacent rooms that share these wall types with that room.

Any outlet can be moved, deleted, or merged with other outlets or switches. See “Switches” on page 229.

Electrical Library



Select **Library > Library Browser** to access a variety of electrical symbols. See “The Library” on page 282.

Browse for electrical objects such as bath vent fans, an electrical panel, fluorescent

lights, chandeliers, a smoke detector, thermostat, and more. Select a symbol, then click in your plan to place it on a wall, floor, or ceiling.

Displaying Electrical Objects



The display of electrical objects and connections is controlled in the **Display Options** dialog. See “Displaying Objects” on page 59.

When displayed in 3D views, light fixtures act as sources of light that help illuminate the 3D model. See “Lighting” on page 337.

Electrical labels display in floor plan view when the “Electrical, Labels” layer is turned on.

In the Materials List

Electrical objects, including outlets, switches, lights, and symbols from the library, are listed under the Electrical Category in the Materials List. See “Materials Lists” on page 392.

Editing Electrical Objects

Electrical objects can be selected as a group and individually in 2D and 3D and edited using the edit handles and the edit toolbar .

Using the Edit Handles

The edit handles for electrical objects vary depending on the location of the object. Wall

mounted electrical objects cannot be rotated, so only the Move edit handle displays.

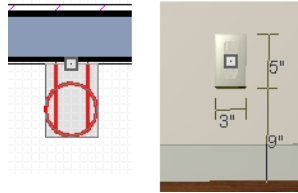

Wall-mounted outlet in 2D and 3D views

Electrical objects placed on floors and ceilings can be rotated.

Electrical connections edit like splines. See “Editing Spline Based Objects” on page 84.

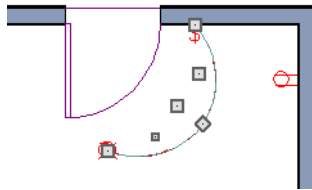

Using the Edit Buttons

A selected electrical symbol can be edited in a variety of ways using the buttons on the edit toolbar. See “The Edit Toolbar” on page 21.

Adjusting the Height of Electrical Objects

In floor plan view, an outlet placed where a base cabinet meets a wall is placed above the counter unless the cabinet contains a fixture or appliance other than a bathroom sink. If

the fixture requires electricity, the outlet remains behind the cabinet at normal wall height, where it can supply power to the fixture or appliance.

Kitchen sinks are assumed to require electricity since they often contain a garbage disposal. Dishwashers are not considered to require electricity since they are usually plugged in under a nearby sink. If an outlet is needed above a cabinet containing a kitchen sink, place the outlet before adding the sink, or move the outlet up.

To change the height of an electrical object in floor plan view, open the object for specification and type the desired height in the **Electrical Service Specification** dialog. See “Electrical Service Specification Dialog” on page 232.

Electrical objects placed in 3D views are placed wherever you click a wall, regardless of the height. In 3D views, the position of an electrical object can be adjusted using its edit handles.

Deleting Electrical Objects

An electrical object can be deleted by selecting it and clicking the **Delete**  edit button or by pressing the Delete key.

All electrical objects in a room, on a floor, or in the entire plan can be deleted as a group using the **Delete Objects** dialog. See “Deleting Objects” on page 93.

Electrical Service Specification Dialog



Select an electrical object and click the **Open Object** edit button to open

the **Electrical Service Specification** dialog. The settings in this dialog vary, depending on the type of object(s) you select.

General Tab

The items on this tab vary, depending on the type of electrical object selected.

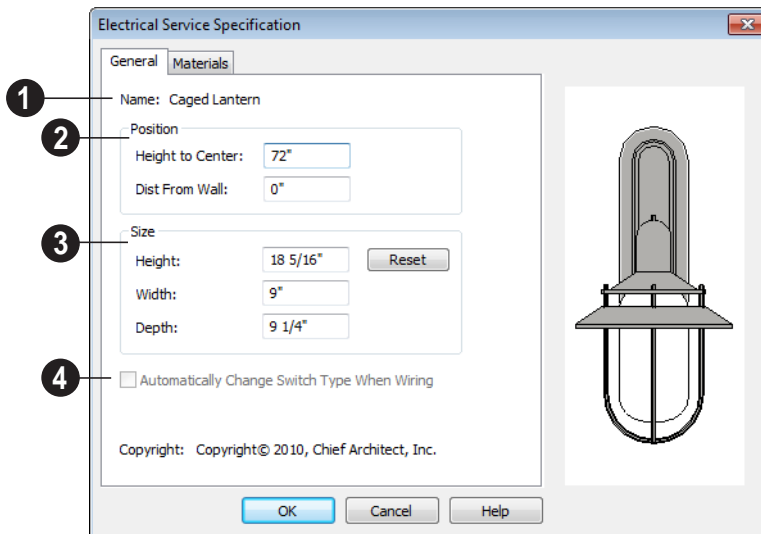

- 1 The **Name** of the selected object as used in the Library Browser and Materials List displays here.
- 2 Specify the **Position** of the selected electrical symbol. The options available depend on the type of electrical symbol selected.
 - Specify the **Offset From Ceiling** of a ceiling outlet or ceiling mounted light. If the light is mounted to a cabinet, this value is the offset from the cabinet.
 - Specify the **Height to Center** of a switch, wall outlet or wall light.
- 3 Specify the **Size** of the selected electrical symbol.
 - Specify the **Height, Width** and **Depth** of the selected symbol.
 - Click the **Reset** button to restore the electrical symbol's original size
- 4 Check **Automatically Change Switch Type When Wiring** for a selected
 - Specify the **Offset From Floor** of a floor outlet or floor lamp.
 - Specify the **Distance From Wall** of a wall mounted symbol. A negative value will recess the symbol into the wall and may prevent it from being seen in 3D.

switch to become a three- or four-way switch if your wiring plan later uses it as such. See “Connect Electrical” on page 230. Switches placed from the toolbar use this option by default; switches placed from the library do not. Only available for switches.

Materials Tab

The Materials tab is found in the specification dialogs for a variety of objects. For more information, see “Materials Tab” on page 303.

Trim Tools

The Trim Tools allow you to place corner boards and quoins at wall intersections that form corners.

You can also assign moldings to a variety of objects, such as rooms and cabinets, in those objects' specification dialogs. See "Specification Dialogs" on page 23.

Chapter Contents

- Trim and Molding Defaults
- Corner Boards
- Corner Board Specification Dialog
- Quoins
- Quoin Specification Dialog
- Editing Corner Boards and Quoins
- Millwork

Trim and Molding Defaults



Select **Edit> Default Settings** to open the **Default Settings** dialog where you can access the defaults for a variety of drawing tools, including a number that affect trim and moldings.

- Select “Floor” and click the **Edit** button to specify the default moldings for rooms on the current floor. See “Floor Defaults” on page 121.
- Click the + beside “Door” ” to access the defaults for Interior and Exterior Doors. See “Door Defaults” on page 138.

- Select “Window” and click the **Edit** button to specify the default casing for windows. See “Window Defaults” on page 155.

Wall and Full Height cabinets in many of the new plan Style Templates have crown molding. These cabinets can be placed from the library into any plan. See “Cabinet Defaults” on page 242.

Corner Boards



Corner boards are added to a building exterior in any view by selecting **Build> Trim> Corner Boards**.



Click at a wall corner where you want to add trim. Be sure to click where the outside wall surfaces meet. If you click where the inside surfaces meet, corner trim will be created inside the room.

.Corner boards extend from the top plate down to the bottom of the floor platform of the floor on which it is placed, but do not extend to other floors. You must add corner boards to all floors of the building that you want to have corner boards.

A selected corner board or boards can be moved, but only to another wall corner or corners. In 3D views, corner boards can be lengthened or shortened using the edit handles. Corner boards can be copied, deleted and resized similar to other objects using the edit toolbar or the **Corner Board Specification** dialog.

The default material for corner boards is defined by the **Exterior Trim** entry in the **Material Defaults** dialog. See “Material Defaults” on page 308.

Corner Board Specification Dialog



Select a corner board and click the **Open Object** edit button to open the **Corner Board Specification** dialog.

General Tab

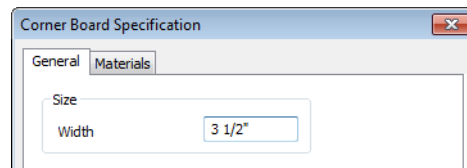

Specify the **Width** of the selected corner board(s).

Materials Tab

The settings on the Materials tab are available for a wide variety of objects in the program. For information about these settings, see “Materials Tab” on page 303.

Quoins



Select **Build> Trim> Quoins** in any view and click at a wall corner where you want to place quoins.



A selected quoin or quoins can be moved, but only to another wall corner or corners. In 3D views, quoins can be lengthened or shortened using the edit handles. Quoins can be copied, deleted and resized similar to

other objects using the edit toolbar or the **Quoin Specification** dialog.

The size of quoins in floor plan view is relative on their size in 3D.

Initially, quoins use the same material as the default material of the wall surface they are placed against.

Quoin Specification Dialog



Select a quoin and click the **Open Object** edit button to open the **Quoin Specification** dialog.

General Tab

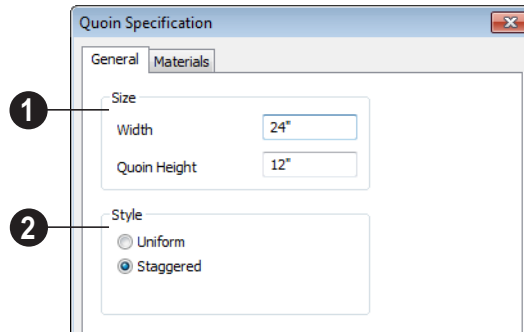

- 1 Specify the dimensions of the quoins in the selected Quoin object.
 - Specify the **Width**, which is the long dimension of each quoin in the selected Quoin object. The dimension along the other wall is half this value when they are staggered or mirrored.
 - Specify the **Quoin Height** for individual quoins in the selected Quoin object.
- 2 Specify the arrangement of quoins used by the selected Quoin object(s).

- **Uniform** - Produce quoins that are of equal length on both sides of the corner.
- **Staggered** - Produce quoins that have one long side and one short side staggered on opposite sides of the corner.

Materials Tab

The settings on the Materials tab are available for a wide variety of objects in the program. For information about these settings, see “Materials Tab” on page 303.

Editing Corner Boards and Quoins

Before a corner board or quoin can be edited, it must be selected. Click on a trim object when the **Select Objects**  tool is active. Corner boards and quoins can also be group

selected and edited. See “Selecting Objects” on page 71

Corner boards and quoins can be edited using their edit handles, the edit toolbar buttons, and their specification dialogs.

Using the Mouse

Depending on the type of view, a corner board or quoin displays a different set of edit handles when selected.

- In floor plan view, corner boards and quoins display one edit handle and can be moved from one eligible location at a wall corner to another.
- In 3D views, corner boards and quoins can be moved, lengthened, and shorted much the other line-based objects are. See “Editing Line Based Objects” on page 73.

Using the Edit Buttons

A selected corner board or quoin can be edited in a variety of ways using the buttons on the edit toolbar. See “The Edit Toolbar” on page 21.

Deleting Corner Trim

Corner boards and quoins can be selected individually or in groups and deleted using the **Delete**  edit button or the Delete key on the keyboard. They can also be removed using the **Delete Objects** dialog. See “Deleting Objects” on page 93.

Millwork

A selection of various types of millwork including columns, corbels and finials is available in the Library Browser. See “The Library Browser” on page 283.

Most millwork items can be placed in a plan as free-standing objects. Some items -

notably, newels and balusters - can be assigned to objects such as railings, stairs and ramps. See “Placing Library Objects” on page 293.

Cabinets

With Home Designer Essentials’s cabinet tools you can create base, wall, and full height cabinets as well as soffits, shelves and partitions. These objects are very versatile, allowing for a wide range of customization.

A selection of cabinet door and drawer styles are available in the Library Browser.

Home Designer Essentials also has many customized cabinet symbols and cabinet groups available in the library.

Chapter Contents

- Cabinet Defaults
- The Cabinet Tools
- Cabinet Fillers
- Placing Cabinets
- Displaying Cabinets
- Editing Cabinets
- Editing Cabinet Styles
- Special Cabinets
- Cabinet Specification Dialog
- Shelf/Partition Specification Dialog

Cabinet Defaults



Access default settings for each cabinet tool by selecting **Edit>**

Default Settings, then clicking the + beside **Cabinets**. Select a subheading and click the **Edit** button to open the defaults dialog associated with your selection:

Each type of cabinet object has default definitions for size, style, materials and more. In fact, the default dialog for each cabinet type is similar to its corresponding specification dialog. For descriptions of

these settings, see “Cabinet Specification Dialog” on page 251, “Shelf/Partition Specification Dialog” on page 256 and “Soffit Specification Dialog” on page 279.

In many of the new plan Style Templates, Wall and Full Height cabinets have crown molding. These cabinets can be placed from the library into any plan. See “Template Plans” on page 32.

General Cabinet Defaults

The **General Cabinet Defaults** dialog can be accessed only from the **Default Settings** dialog.

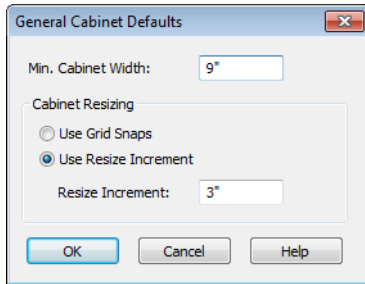

Specify the **Minimum Cabinet Width**. The minimum allowable width is 1/16 of an inch (10 mm).

Specify how **Cabinet Resizing** takes place when the edit handles are used.

- Select **Use Grid Snaps** to resize cabinets using Snap Grid increments. See “Grid Snaps” on page 64.
- Select **Use Resize Increment** to resize cabinets using the increment specified here.
- Set the **Resize Increment** at which cabinets resize. The minimum allowable increment is 1/16 of an inch (10 mm).

The Cabinet Tools



Select **Build> Cabinet** to access the Cabinet Tools.

Cabinets are easily created with a single click in floor plan view or any camera view. See “Click-to-Create” on page 65.

Typically, groups of cabinet objects are positioned closely together and arranged to form work spaces, and there are some special behaviors and techniques to be aware of. See “Placing Cabinets” on page 245.

Once created, cabinets, soffits, shelves, partitions and fillers can be selected and edited much like other box-based objects. See “Editing Cabinets” on page 247.

Base Cabinets



Select **Build> Cabinet> Base Cabinet** and click in any view. Base cabinets can be placed directly under wall

cabinets and generate a countertop and toe kick by default.

Wall Cabinets



To place a wall cabinet, select **Build> Cabinet> Wall Cabinet** and click in any view. Wall cabinets can be placed directly over base cabinets.

Full Height Cabinets



To place a full height cabinet, select **Build> Cabinet> Full Height** and click in any view. Full height cabinets generate a toe kick by default and cannot be placed on top of other cabinets.

Soffits



Soffits typically fill the space between cabinet tops and the ceiling, but can

also be used to create any object that can be modeled as a 3D box. To place a soffit, select **Build> Cabinet> Soffit** and click in any view.

By default, soffits use the material assigned to interior walls in the **Material Defaults** dialog. Like cabinets, soffits can have molding profiles applied to them.

For more information about using soffits for a variety of purposes, see “Other Objects” on page 276.

Shelves



Select **Build> Cabinet> Shelf** and click in any view to create a shelf.

Create corner shelves by placing one shelf on each wall, then moving or stretching them until they touch.

Once created, shelves can be selected and edited. See “Shelf/Partition Specification Dialog” on page 256.

Partitions



Select **Build> Cabinet> Partition** button and click in any view to create a vertical partition.

Like shelves, partitions can be selected and edited after they are placed.

Partitions can be used with shelves to create complex storage systems.

Cabinets Library



In the Library Browser, browse to Home Designer Core Catalogs> Architectural> Cabinets to access a selection of specialty cabinets. Select the library object you want, then click in any view to place it in

the plan. Once placed, library cabinets can be edited. See “The Library” on page 282.

Cabinet Doors, Drawers, & Panels Library



A selection of special cabinet doors, drawers and panels is available in Home Designer Core Catalogs> Architectural. Select an item, then click on a cabinet in your plan to place the door or drawer onto that cabinet. Doors, drawers and panels can be assigned to a cabinet in its specification dialog, as well. Cabinet doors, drawers and panels can also be placed as stand-alone fixtures.

Built-In Appliances

A variety of fixtures and appliances such as sinks, cooktops, and dishwashers can be placed into cabinets. See “Inserted Objects” on page 294.



Place fixtures and appliances into cabinets early, so that any resizing can be done while there is adequate free space.

To insert a fixture into a cabinet, select the fixture in the Library Browser, then click on a cabinet. There must be enough space in the cabinet or adjoining cabinets to contain the selected fixture.

If a sink or cooktop is inserted into a cabinet with a top Drawer or Double Drawer, its Item Type will automatically change to a False Drawer or False Double Drawer.

Once placed, an inserted fixture can be selected and edited:

- To select a fixture in a cabinet top, click on it and then click the **Select Next**

Object  edit button. See “Select Next Object” on page 72.

- Front fixtures can only be modified or deleted in the **Cabinet Specification** dialog. See “Front Tab” on page 252.



Fixtures can be added to both the top and front of the same cabinet. It is up to you to determine which can be effectively and safely combined in the real world.

Electrical Switches & Outlets

Electrical switches and outlets placed. See “The Electrical Tools” on page 229.

Cabinet Fillers

By default, Home Designer Essentials models a continuous countertop and generates fillers automatically when cabinets of the same height are either touching or placed with 3” (30 mm) of one another.

If two cabinets meeting at a corner are separated from each other by 3” (30 mm) or less, the program will automatically generate a filler in the angle between them. A filler is used to separate the front of one of these

cabinets from the one it meets so that drawers and doors have room to operate.

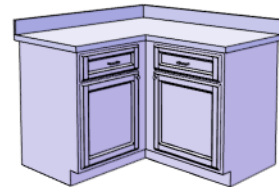
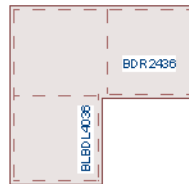

Two base cabinets and the filler between them

Placing Cabinets

Cabinets are easily created with a single click in any view. See “Click-to-Create” on page 65.

When used near a wall corner, the Cabinet Tools will produce corner cabinets and soffits. See “Corner Cabinets” on page 249.

When created, cabinets are positioned relative to the floor of the room in which they are placed. Base and full height cabinets typically rest on the floor while wall cabinets are placed a set distance above the floor. See “Cabinet Defaults” on page 242.

If the ceiling height of the room does not accommodate the height of a cabinet, its **Floor to Bottom** value will be retained and its **Height** will be reduced so that it fits under the ceiling. When this happens, some front items may be removed from the cabinet if there is not enough room for them. See “Front Tab” on page 252.

Because cabinets are typically organized into groups with shared attributes, they have some special behaviors.

Cabinet Snapping and Aligning

Cabinets have several special snapping and aligning behaviors which help you create precisely aligned cabinets quickly and easily.

- When Base and/or Full Height cabinets are within 3” of one another’s sides, they will snap together. Wall cabinets snap in a similar manner, but only with other Wall cabinets.
- When Base and/or Full Height cabinets are within 3” of one another’s sides and their front or back surfaces are within 3” of aligning, they will become aligned. Wall cabinets snap in a similar manner with other Wall cabinets as well as Full Height cabinets.
- When a Base and/or Full Height cabinet is placed against the back of another Base or Full Height cabinet, its back surface will automatically face the other cabinet’s back. Wall cabinets snap in a similar manner with other Wall as well as Full Height cabinets.
- When a cabinet is placed against a wall, its back and/or side will snap to the wall and, if the wall is moved, the cabinet will move with it.

When cabinets are snapped to a wall or to other cabinets, only exposed end cabinets have side counter overhangs.

Cabinet snapping and aligning occurs even when when **Object Snaps** are turned off; however, you can override this behavior by moving a cabinet into the desired position using dimensions. See “Moving Objects Using Dimensions” on page 350.

Cabinet Merging

When cabinets of the same height and type are placed side-by-side within 3” (30 mm) of one another they will automatically merge, making any shared components such as the toe kick, countertop, backsplash and moldings continuous. Any gap between merged cabinets will be automatically filled.

The exposed ends of merged cabinets have side counter overhangs.

Cabinets placed at different angles will also merge if they face toward one another and meet at a front corner. Cabinets that meet at a back corner will also merge provided that they face away from one another at an angle no greater than 87°. In either case, a filler is created in the angle between the two.

If the side of a cabinet is placed within 3” (30 mm) of a wall, the countertop will extend to the wall and a filler will be created.

Base and Wall Cabinets

Base and wall cabinets have different default heights, so they can be placed directly above or below one another without interference. You can use **Object Snaps** to center a wall cabinet’s back center point above that of a base cabinet, or vice versa. See “Click-to-Create” on page 65.

Minimum Cabinet Size

If you try to place a cabinet into a space that is too narrow for its default size, the program will place a smaller cabinet with a width that is a multiple of the default **Resize Increment**. For example, if you try to place a 24” wide cabinet in a 20” wide space and your Resize Increment is 3”, the program

places an 18" cabinet. See "General Cabinet Defaults" on page 243.

If you try to place a cabinet into a space narrower than the default **Minimum**

Cabinet Width, a cabinet will not be placed. If, for example, you have a space that is 8" and your Minimum Cabinet Width is 9", no cabinet is placed.

Displaying Cabinets



The display of the various cabinet object types, labels, module lines, door opening indicators and more is controlled in the **Display Options** dialog. See "Displaying Objects" on page 59.

Cabinets are drawn so that wall cabinets, soffits and shelves are always in front of base and full height cabinets and partitions.

Countertops display if the "Cabinets, Countertops" layer is turned on.

By default, cabinet module lines display in floor plan view when cabinet objects of the same type are placed side by side. If you prefer that these lines not display, turn off the "Cabinets, Module Lines" layer. You can also specify whether module lines are full or partial.

You can also display cabinet front indicator arrows in floor plan view by turning on the "Cabinets, Front Indicators" layer.

Editing Cabinets

Cabinets can be selected in 2D and 3D views and edited using the edit handles, the edit toolbar and their specification dialog.

Using the Mouse

Cabinets can be edited like other box-based objects. See "Editing Box-Based Objects" on page 82. The edit handles that a cabinet displays when selected will vary depending on the view.

When a cabinet is selected in floor plan view or on its top surface in a 3D view, ten edit handles display: the Move handle at the center, the Rotate handle, and a Resize handle on each edge and at each corner.

In 3D views, cabinets can be selected on any surface: front, side, back or top. When the

side of a cabinet is selected, five edit handles are available: the Move handle and a Resize handle on each edge.



In the Specification Dialog



A selected cabinet can be customized in a variety of ways in its specification dialog. See "Cabinet Specification Dialog" on page 251.

Using the Edit Tools

A cabinet or cabinets can be edited in a variety of ways using the buttons on the edit toolbar. See “The Edit Toolbar” on page 21.

Moving Walls with Cabinets Attached

When a cabinet is placed or moved against a wall, it will snap to the wall and become

attached to it. When a wall is moved, all attached cabinets move with it.

Moving a wall to an unattached cabinet will not attach the cabinet to it: the cabinet must be moved to the wall. A cabinet can also be attached to a wall when **Plan Check**  is used. See “Plan Check” on page 368.

Editing Cabinet Styles

A variety of settings allow you customize the appearance of your cabinets to create styles ranging from traditional to contemporary.

If the desired style is known before cabinets are placed, you can save time by specifying that style in the **Cabinet Defaults** dialogs before you start drawing. See “Cabinet Defaults” on page 242.

Cabinet Front Items

A variety of different front items can be added to any cabinet, including doors, drawers, cutting boards, and horizontal separations. Front items can also be moved, resized, as well as removed. See “Front Tab” on page 252.

Doors, Drawers & Panels

Cabinet doors can be applied in either of two ways:

- In the **Cabinet Specification** dialog. See “Door/Drawer Tab” on page 254.
- Directly from the Library Browser.

Select a style in the library, then click on a cabinet to apply the selected style to that cabinet. In 3D views, click on a face item to apply the selected library object to that item. See “Placing Library Objects” on page 293.

Cabinet Hardware

Cabinet handles, pulls, and hinges can be assigned in the **Cabinet Specification** dialog. See “Door/Drawer Tab” on page 254.

In 3D views, pulls and handles can also be applied directly from the Library Browser. Select a hardware item, then click on the cabinet face item to apply it to that face item.

Countertops & Backsplashes

Countertop thickness, and material for a selected base cabinet can be specified in the **Base Cabinet Specification** dialog. See “Front Tab” on page 252.

Backsplashes can also be applied to base cabinets, also on the Front tab of their specification dialog.

Special Cabinets

There are a number of special cabinet shapes that can be specified. Certain requirements must be met before some special cabinet shapes can be specified. If the requirements are not met, a warning message will explain what is needed. See “Cabinet Specification Dialog” on page 251.



Standard Cabinets

Select **Build > Cabinet > Base Cabinet**  and click in floor plan view to place a standard, rectangular base cabinet.



Standard (default) cabinet

Corner Cabinets

To create a corner cabinet, click as close to an inside wall corner as possible in using either the **Base Cabinet** , **Wall Cabinet** , or **Full Height**  cabinet tool. A corner cabinet remains a corner cabinet when it is moved, edited or copied.

Turn an existing cabinet into a corner cabinet by selecting Corner Cabinet from the **Special** drop-down list in its specification dialog. See “General Tab” on page 251.

- Before a corner cabinet can be specified in the **Cabinet Specification** dialog, the

cabinet’s Width must be greater than its Depth.

- The **Left** and the **Right Side Widths** can be set independently for corner cabinets.



Corner cabinet with sides of equal width

- You can specify a Diagonal Door on corner cabinets to create an angled corner cabinet. See “Front Tab” on page 252.



Corner cabinet with diagonal door

End Cabinets

Open a cabinet for specification and select Left or Right End Cabinet from the **Special** drop-down list to create an end cabinet.



Left End Cabinet

- End Cabinets have an angled front and side.
- The cabinet width must be no greater than its depth for an end cabinet to be specified.

Radius End Cabinets

Open a cabinet for specification and select Right or Left Radius End from the **Special** drop-down list to create a radius end cabinet.



Radius End cabinets have a 90° arch

As you face the cabinet, a right radius end curves to the right, and a left radius end curves to the left.

Peninsula Radius Cabinets

Open a cabinet for specification and select Pen. Radius from the **Special** drop-down list to create peninsula radius cabinet.



Peninsula Radius Cabinet

Kitchen Islands

To create a kitchen island, simply place several cabinets back-to-back and/or side-to-side. Match the widths so that each cabinet back or side meets the back or side of only one other cabinet. If this is not done, the lines separating the cabinets cannot be suppressed.

Two cabinets cannot merge with the same side of another cabinet. The picture shows two instances when cabinets are placed back-to-back. Cabinet fronts and joining surfaces are shown.

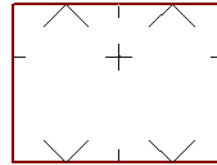

*Correct -
Widths of front and
back cabinets match*

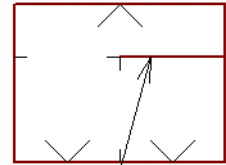

*Incorrect -
Solid line here is not
suppressed.*

Blind Cabinets

Often, when two cabinets meet in a corner, one is partially hidden by the other. This partially hidden cabinet is called a “blind” cabinet. Home Designer Essentials will resize and offset the front items of the partially hidden cabinet so that they are not located in the hidden portion of the cabinet face.

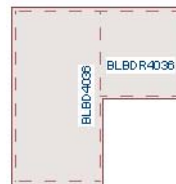

Cabinet Specification Dialog



Select a cabinet and click the **Open Object** edit button to open the **Cabinet Specification** dialog.

The options in the **Cabinet Specification** dialogs are similar to the corresponding **Cabinet Defaults** dialog. See “Cabinet Defaults” on page 242.

General Tab

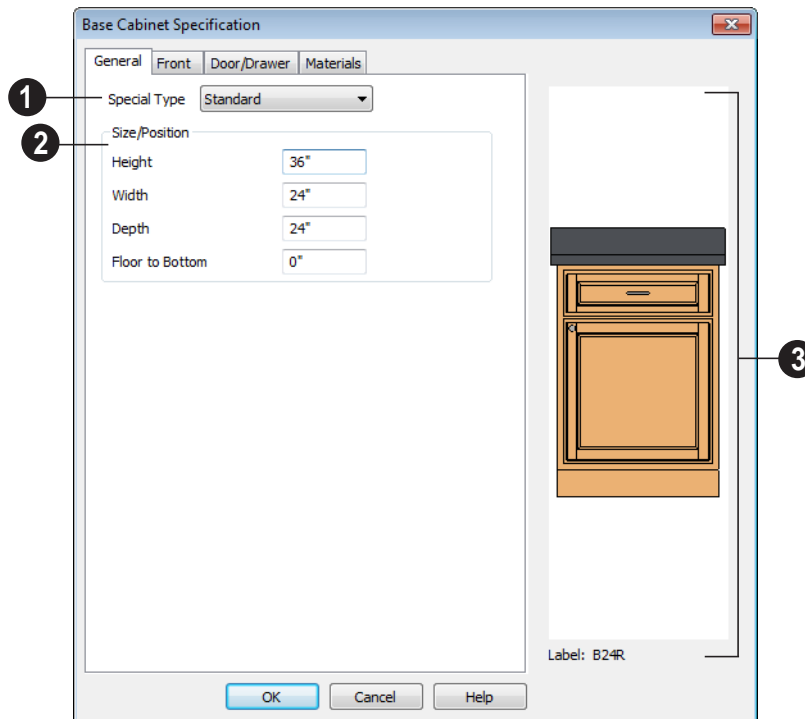

1 A number of **Special** cabinet types are available in the drop-down list. Certain requirements must be met before some special cabinet shapes can be specified. See “Special Cabinets” on page 249.

2 **Size/Position** - The selected cabinet’s dimensions and position relative to the

floor can be specified here. Fractional values are supported to 1/16th of an inch (1 mm).

- Specify the **Height** of the cabinet box, as measured from bottom to top. For base cabinets, this value includes the counter-top thickness, but not the height of the backsplash.

- Specify the **Width** of the cabinet box, as measured across the front of the cabinet box from left to right. This does not include the countertop overhang.
- Specify the **Depth** of the cabinet box, as measured from front to back. It does not include the thickness of overlay doors or the countertop overhang.
- For corner cabinets, the **Width** and **Depth** fields become **Right Side Width** and **Left Side Width**.
- Specify the **Floor to Bottom** distance. For base and full height cabinets, this is usually 0.
- When the selected cabinet is outside a room and **Auto Adjust Height** is checked, its Floor to Bottom height is measured relative to the terrain height. When this is unchecked, the Floor to Bottom height is measured from the default floor height of Floor 1. See “Terrain Height vs Floor Height” on page 259 of the Reference Manual.
- ③ The preview of the cabinet updates as the cabinet changes.
- The **Cabinet Label** displays below the preview diagram.

Front Tab

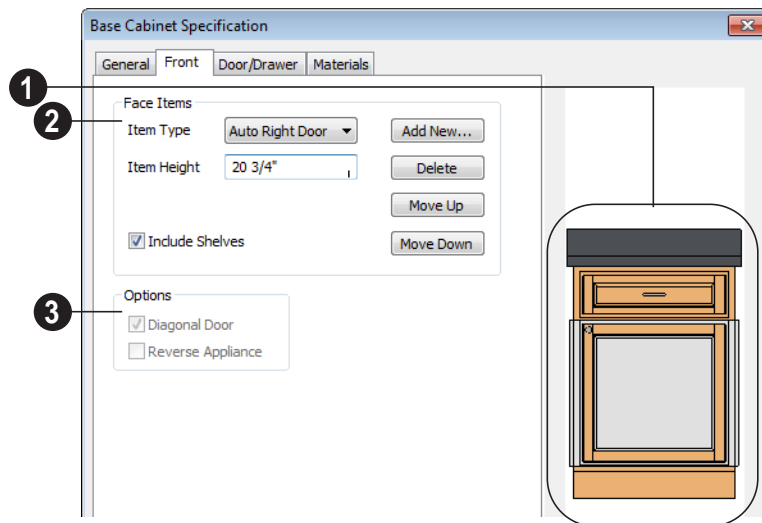

- ① Click on a face item in the preview diagram to select it. The selected item is highlighted, and the **Face Items** settings below become active, allowing you to edit the selected item.

- ② Define the **Face Items** on the front of the selected cabinet. For best results, edit face items starting at the top of the cabinet and work down.

Click the **Item Type** drop-down list to apply a type to the selected Face Item, such as a door, drawers or panel.

- Cabinet fronts may be composed of any combination of face items, but there is a limit to the number of items that can reasonably fit on a given cabinet's front.
- Auto Right and Auto Left Doors become double doors automatically when the cabinet width is greater than 24" (600 mm). Left, Right and Double Doors are as specified regardless of the cabinet width.
- False Drawers assume the appearance of the drawer style and hardware assigned to the cabinet.
- Door Panels assume the appearance of the cabinet's door style but without door hardware.
- The backslash can be selected but its Type cannot be changed.

Item Height - Define a value for the selected item in the cabinet front. Fractional heights are supported to 1/16th of an inch (1 mm).

- When the height of a cabinet is changed, or the height of a face item is changed, the height of the lowest face item is altered to make up the difference.
- If you modify the lowest item, the item directly above is adjusted. Set the countertop height and the toe kick height first, and then work from the top to the bottom when adjusting face items.
- If the height of an appliance has been altered, entering "d" restores its default height.

Note: To ensure that Face Item heights always equal the total cabinet front height, the program automatically adjusts the bottom Face Item as changes are made elsewhere. This means you should start editing Face Items at the top and work down.

Check **Include Shelves** to include shelves in the selected "Door" or "Opening" face item.

Click **Add New** to add a new face item directly below the currently selected item.

- When you click **Add New**, the **New Cabinet Face Item** dialog displays. Define the **Item Type**, **Item Height** and click OK.

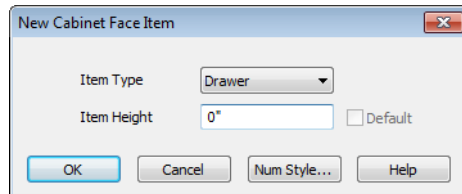

- If you click **Add New** with no face item selected, the program adds the new item at the bottom of the cabinet face.
- When a face item is added to the cabinet front, the program attempts to reduce the height of the lowest item on the cabinet front to make room for the new item.

Click **Delete** to remove the currently selected item.

- When a face item is deleted, the height of the lowest item is usually increased to make up the difference.
- When an Auto Left, Auto Right, Left, Right, or Double Door is deleted, it is replaced by an Opening.

Click **Move Up** to move the currently selected item up one position, switching places with the item directly above.

Click **Move Down** to move the currently selected item down one position, switching places with the item directly below.

Note: The program tries to maintain a single separation between all face items. When you add or delete a face item, separations are usually added or deleted with them.

3 Options -

- Uncheck **Diagonal Door** to create double doors at right angles instead of a single diagonal door. This option is only available for Corner Cabinets and is checked by default in the **Cabinet Defaults** dialog.
- Select **Reverse Appliance** to reverse the fixture from left to right: for example, to change a left hand door on a built-in refrigerator to a right hand door. This option is only available for cabinets with an inserted appliance.

Door/Drawer Tab

The settings on the Door/Drawer tab allow you to control the appearance of the selected cabinet's doors and hardware.

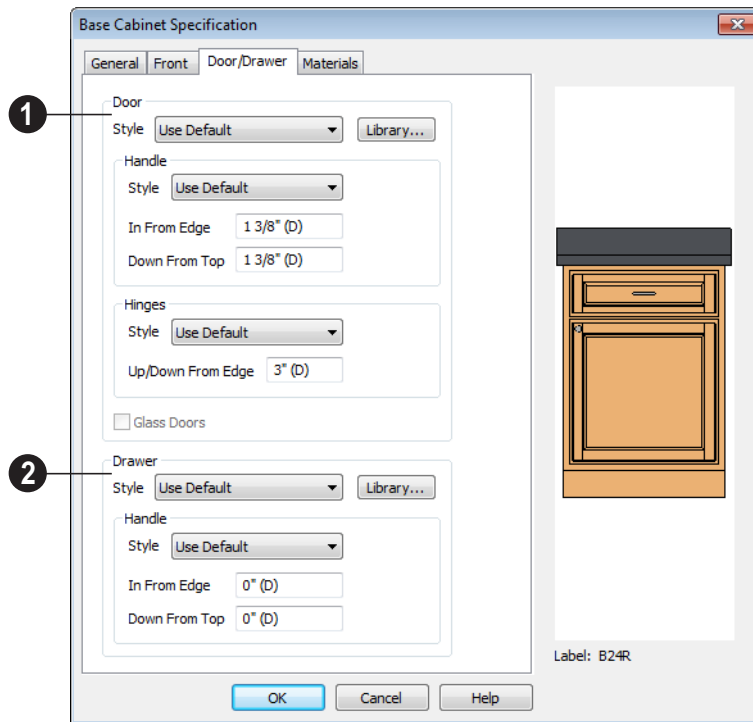

1 Specify the style and hardware for any **Doors** applied to selected cabinet(s).

Select a door **Style** from the drop-down list. See “Doors, Drawers & Panels” on page 248.

- Select “Use Default” to apply the door style specified in the defaults dialog for the selected cabinet’s type. See “Cabinet Defaults” on page 242.
- Select “Slab Doors” to apply a flat door front or “Framed Doors” to apply a door with a frame and flat panel front.
- Select “Library” or click the **Library** button to select a cabinet door from the library. If a library door has been previously selected, its name will display in

the list. See “Select Library Object Dialog” on page 295.

Specify the characteristics of the cabinet’s door **Handles**.

- Select a door handle **Style** from the drop-down list or choose one from the library.
- Specify the position of the handle **In From Edge**, as measured from the edge of the door opposite the hinges.
- Specify the height of the handle **Down From Top**, as measured from the top edge of the door. For wall cabinets, this value is measured **Up From Bottom**.

Specify the characteristics of the cabinet door **Hinges**.

- Select a door hinge **Style** from the drop-down list or choose one from the library.
- Specify the location of the hinges **Up/Down From Edge**, as measured from the door edge. If the cabinet door is more than 35 1/4" (880 mm) high, three hinges will be created instead of two.

Glass Doors is available for cabinets with Slab or Framed doors. Framed door panels are created using a glass material. The entire door is glass on Slab doors.

- 2 Specify the style and hardware for any **Drawers** applied to the cabinet(s).

Select a from the drop-down list or choose one from the library. For best results, Framed drawers should be at least 6" (150 mm) high.

Select a drawer from the drop-down list or choose one from the library.

- The **In From Drawer Edge** setting creates two handles the specified distance from the left and right drawer edges. A value of 0 creates a single handle centered horizontally on the drawer.
- Specify the location of the handle **Down From Top**. A value of 0 centers the handle vertically on the drawer.

Materials Tab

The settings on the Materials tab affect the appearance of the selected cabinet in 3D views. For information about these settings, see "Materials Tab" on page 303.

Shelf/Partition Specification Dialog



Select a shelf or partition and click the **Open Object** edit button to open the **Shelf Specification** or **Partition Specification** dialog.

The options in these specification dialogs are similar to the corresponding defaults dialogs. See "Cabinet Defaults" on page 242.

General Tab

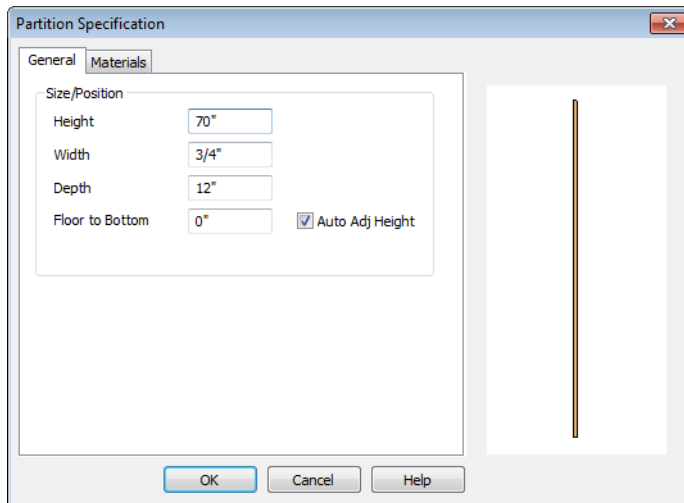

Specify the **Height**, **Width**, **Depth**, and the distance from the **Floor to Bottom** of the shelf or partition.

When the selected object is outside a room and **Auto Adjust Height** is checked, its Floor to Bottom height is measured relative to the terrain height. When this is unchecked, the Floor to Bottom height is measured from the default floor height of Floor 1. See

“Terrain Height vs Floor Height” on page 259 of the Reference Manual.

Materials Tab

The settings on the Materials tab affect the appearance of the selected object in 3D views. For information about these settings, see “Materials Tab” on page 303.

Terrain

Home Designer Essentials allows you to model surface features such as planting areas, water features and plants in level terrain around your house plan.

Driveways, parking lots and sidewalks are among the objects that can be placed in your terrain and are discussed in “Sidewalks, Driveways & Parking Lots” on page 272.

Chapter Contents

- Terrain Perimeter
- Terrain Feature Tools
- Garden Bed Tools
- Water Feature Tools
- Terrain Objects in the Library
- Displaying Terrain
- Editing Terrain Objects
- Terrain Object Specification Dialogs
- Plants
- Plant Image Specification Dialog

Terrain Perimeter



The Terrain Perimeter is a closed polyline defining the boundary of the terrain that generates in 3D views. A Terrain Perimeter should be present in your plan already, but if one is not, select **Terrain> Create Terrain Perimeter** to create one.

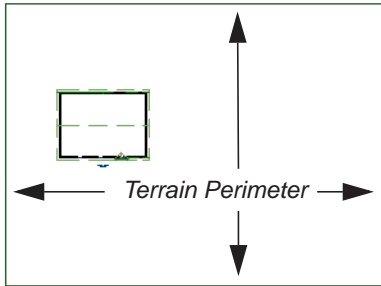

If you create a terrain perimeter in floor plan view but do not see it, select **Window > Fill Window** . See “Zoom Tools” on page 311.

Once created, the terrain perimeter can be resized and edited like other polyline-based objects. See “Editing Closed-Polyline Based Objects” on page 80.



Terrain perimeter in a 3D view

Terrain Height vs Floor Height

Home Designer Essentials always defines the default height of Floor 1 at 0’-0”. This height value is the constant by which the heights of

architectural objects and structural elements in the program, including walls, floors, and ceilings, are measured.

The default height of Floor 1 is not, however, the absolute by which terrain elevation is measured. The program automatically positions Floor 1 a set distance above the terrain. This Elevation distance is 6” (150 mm) plus the thickness of the floor platform when a foundation is present.

Once terrain has been built, the Elevation distance is stated in the **Terrain Specification** dialog. You can specify a custom Elevation value to produce a daylight or walkout basement. See “General Tab” on page 264.

Note: When no foundation has been built, the distance from Floor 1 to the terrain is 12” (320 mm).

Build Terrain



Select **Terrain > Build Terrain** to generate the terrain surface with any terrain features and roads you have drawn. Build Terrain also updates the Building Pad Elevation value in the **Terrain Specification** dialog. See “Building the Terrain” on page 262.

The Terrain Perimeter has a variety of editable properties that affect the appearance of the terrain in 2D and 3D views. See “Terrain Specification Dialog” on page 263.



Terrain Breaks

Terrain Feature Tools



Select **Terrain > Feature** to access tools for drawing bounded areas that follow the contours of the terrain rather than modifying them.

Terrain Features are useful for creating landscaping features because they have specified heights and materials. You can, for example, create paths and planting beds with gravel or mulch materials that stand out in a grassy Terrain Perimeter. See “Adding Terrain Features” on page 143 of the User’s Guide.

In fact, **Driveways** , **Garden Beds**  and **Water Features**  are special Terrain Features with material and height attributes already applied to them, saving you time when drawing these objects.

Terrain Features can only be drawn when a Terrain Perimeter is present, and will only display in 3D when they are drawn within the perimeter. See “Displaying Terrain” on page 262.

Terrain Features can be created in either of two ways:

- Click once to place a feature with end-points that form a 10’ (4 m) square at that location.
- Click and drag from end to end to draw a feature sized as needed.

Once created, Terrain Features can be edited into nearly any shape you require. See “Editing Closed-Polyline Based Objects” on page

80 and “Editing Spline Based Objects” on page 84.



Terrain Features can be drawn in 2D and 3D views.

Rectangular Features



The **Rectangular Feature** tool can be used to create straight-sided features that can be edited into a wide variety of shapes.

Rectangular Features can also be edited like other closed polyline-based objects. See “Editing Closed-Polyline Based Objects” on page 80.

Round Feature



The **Round Feature** tool can be used to create features with rounded edges and smoothly curved corners.

Round Features can be edited like other closed spline-based objects. See “Editing Spline Based Objects” on page 84.

Kidney Shaped Features



The **Kidney Shaped Feature** tool allows you to quickly create features with curved edges, smooth corners and a right angle bend in its shape.

Kidney Shaped Features can be edited like other closed spline-based objects. See “Editing Spline Based Objects” on page 84.

For information about adding height and material information to Terrain Features, see

“Terrain Feature Specification Dialog” on page 265.

Garden Bed Tools



Select **Terrain> Garden Bed** to access tools that can be used to place garden bed features in your terrain.

Garden Beds are basically **Terrain Features** with material and height attributes typical of planting beds. See “Terrain Feature Tools” on page 260.

In addition, you can choose to distribute copies of a plant image within a Garden Bed. See “Distributed Plant Tab” on page 266.

Polyline Garden Bed



This tool draws a garden bed with straight sides and four right angles. See “Rectangular Features” on page 260.

Round Garden Bed



Use this tool to draw garden beds with rounded edges and smoothly curved corners. See “Round Feature” on page 260.

Kidney Shaped Garden Bed



You can draw a kidney shaped garden bed with this tool. See “Kidney Shaped Features” on page 260.

Once drawn, Garden Beds can be selected and edited just like other Terrain Features.

Specify the material and set the height of Garden Beds in the **Terrain Feature Specification** dialog. See “Terrain Feature Specification Dialog” on page 265.

Water Feature Tools



Select **Terrain> Water Feature** to access tools for drawing ponds in your terrain.

Ponds are basically **Terrain Features** with material and height attributes typical of bodies of water. See “Terrain Feature Tools” on page 260.

Round Pond



Use this tool to draw a pond with rounded edges. See “Round Feature” on page 260.

Kidney Shaped Pond



This tool draws a kidney shaped pond. See “Kidney Shaped Features” on page 260.

Terrain Objects in the Library



The Library Browser contains a variety of objects that can be placed in a plan's terrain, including plants, exterior fixtures, accessories and roadway objects. See "The Library Browser" on page 283.

You can also create your own objects and save them in the library. Select any combination of elevation points, elevation

lines, terrain features, roads, sidewalks, road markings, or even the terrain perimeter itself and send them to the library as one unit. This library object can then be placed into any plan. Once placed into a plan, each object is independent and is no longer part of the group. See "Adding Library Content" on page 290.

Displaying Terrain



The display of terrain objects in 2D and 3D views is controlled in the **Display Options** dialog. See "Display Options Dialog" on page 60.

You can customize appearance of Terrain Features, Sidewalks and other terrain objects in floor plan view by changing their line and fill styles. See "Terrain Object Specification Dialogs" on page 263.

Plant images are represented in floor plan view by 2D symbols. You can select a plant's symbol in the **Plant Image Specification** dialog. See "Image Tab" on page 270.

In 3D Views

In order for objects such as Terrain Features and Sidewalks to be visible in 3D views, the Terrain Perimeter layer must also display. In addition, only the portions of these objects that are drawn within the Terrain Perimeter will be seen in 3D views. See "Terrain Feature Tools" on page 260.

A variety of tools are available to help you adjust the perspective of your 3D views. See "Editing 3D Views" on page 328.

Building the Terrain



Terrain is generated based on settings in the **Terrain Specification** dialog and the presence of any terrain features and roads in the plan. See "Terrain Specification Dialog" on page 263.

The terrain is automatically built before a 3D view is generated. This process takes a variable amount of time, depending on the number of terrain features in the plan. The **Building Terrain** progress dialog displays as terrain is generated, sometimes only briefly, indicating the progress.

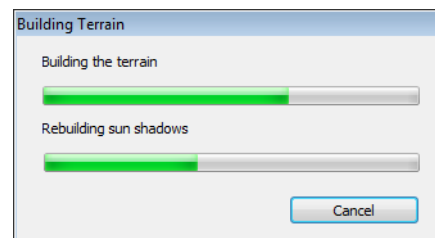

You can rebuild the terrain at any time by selecting **Terrain > Build Terrain** .

Terrain & 3D Drawing Time

Terrain is typically large with many surfaces, which often increases the drawing time of 3D views. The time required is affected by the number of terrain features present.

Lights and symbols can be placed outdoors and included in 3D views when the terrain is generated. These objects can also contribute to the time needed to generate 3D views. See “Rendering Tips” on page 336.

Editing Terrain Objects

Before a terrain object can be edited, it must be selected. All terrain objects can be selected in floor plan and 3D views. See “Selecting Objects” on page 71.

A selected terrain object can be edited using its edit handles, edit tools and specification dialog. See “Specification Dialogs” on page 23.

Using the Edit Handles

- The shape of the Terrain Perimeter can be edited like other polyline-based objects. See “Editing Closed-Polyline Based Objects” on page 80.
- Terrain Features are edited like other spline- and polyline-based objects. See

“Editing Closed-Polyline Based Objects” on page 80 and “Editing Spline Based Objects” on page 84.

Using the Edit Tools

A selected terrain object can be edited in a variety of ways using the buttons on the edit toolbar. The edit tools available for a terrain object depends on the type of terrain object selected. See “The Edit Toolbar” on page 21.

Note: If you copy terrain objects from one plan to another, you cannot view the pasted objects in 3D unless a Terrain Perimeter exists.

Terrain Object Specification Dialogs



Just as there are a number of different types of terrain objects, there are a



number of different specification dialogs for them.

Terrain Specification Dialog



The **Terrain Specification** dialog controls the appearance of your terrain.

The **Terrain Specification** dialog can be accessed in any of two ways:

- Select the Terrain Perimeter and click the **Open Object**  edit button.
- Double-click the Terrain Perimeter using the **Select Objects**  tool.

General Tab

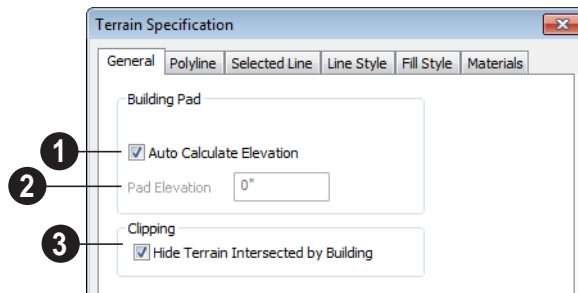

- 1 Check **Auto Calculate Elevation** to automatically calculate the building pad elevation value during terrain rebuild. Home Designer Essentials takes the center of the building footprint and finds the terrain elevation at this point. This elevation is added to 8, 12, or 18 inches to calculate the building pad elevation. 8 inches is used for a slab foundation, 18 is used if a foundation floor is present, and 12 is used otherwise.

- 2 **Building Pad Elevation** - Enter the value of the elevation of the floor height of the first floor in your plan. This option is only available when Auto Calculate Elevation is unchecked.

For example, if a structure is placed in the middle of a terrain sloping evenly from a height of 100.00' to a height of 112.00', entering a value of 106.00' for the building pad elevation will display the structure at the correct height in 3D views.

- 3 Check **Hide Terrain Intersected by Building** to cut out the portion of the terrain that is intersected by the first floor footprint.

Polyline Tab

The Polyline tab indicates the polyline's **Length/Perimeter**, its enclosed **Area**, and its **Volume**.

The settings on the this tab are available for a variety of other objects in the program. For information about these settings, see "Polyline Tab" on page 222.

Selected Line Tab

The Selected Line tab is available when the selected edge of the Terrain Perimeter is a line as opposed to an arc. See "Selected Edge" on page 71.

The settings on this tab are available for a variety of other objects in the program. For information about these settings, see "Selected Line Tab" on page 222.

Selected Arc Tab

The Selected Arc tab is available when the selected segment of the polyline is an arc as opposed to a line. See "Change Line/Arc" on page 92.

The settings on this tab are available for a variety of other objects in the program. For

information about these settings, see “Selected Arc Tab” on page 223.

Line Style Tab

The settings on the Line Style tab are available for a variety of other objects in the program. For information about these settings, see “Line Style Tab” on page 225.

Fill Style Tab

The settings on the Fill Style tab affect the appearance of the Terrain Perimeter in floor

plan view. For information about these settings, see “Fill Style Tab” on page 225.

Materials Tab

The settings on the Materials tab let you specify the terrain surface and terrain skirt materials used in 3D views. These materials are not calculated in the Materials List. See “Materials Tab” on page 303.

Terrain Feature Specification Dialog



To open the **Terrain Feature Specification** dialog, select a Terrain Feature and click the **Open Object** edit button or double-click the Terrain Feature using the **Select Objects**  tool.

The settings in this dialog control the appearance, size, and shape of the selected Terrain Feature.

Most of the tabs in this dialog are similar to those for a variety of other objects in the program.

General Tab

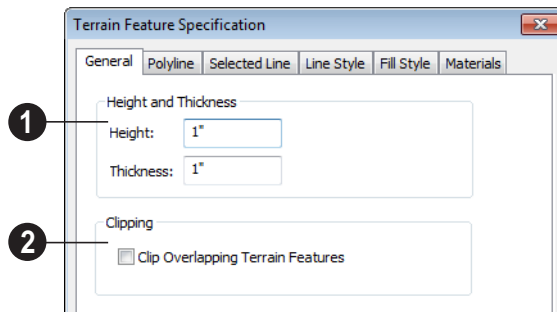

1 Specify the **Height and Thickness** of the terrain feature relative to the terrain surface.

- Specify the top **Height** of the feature using a positive or negative number.
- Specify the feature’s **Thickness**.

If a feature's height above the terrain is greater than its thickness, the program will fill in the resulting gap.

- 2 **Clipping** - Check **Clip Overlapping Terrain Features** to suppress the 3D

display of any part of the selected Terrain Feature intersected by other Terrain Features with a lower Height value. Clipping is useful for creating features that contain other features such as planters or swimming pools.

Distributed Plant Tab

This tab is only available when the selected terrain feature is a Garden Bed. See “Garden Bed Tools” on page 261.

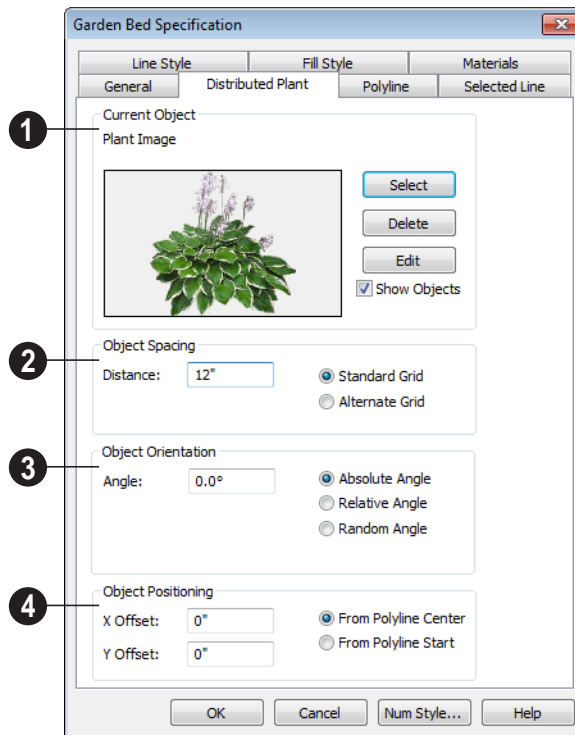

- 1 **Current Object** - Specify the object assigned to the selected region.
- Click the **Select** button to choose an object from the library. See “Select Library Object Dialog” on page 295.
 - A preview of the Current Object along with its name display to the left.
 - Click the **Delete** button to unassign the Current Object from the selected region.

- Click the **Edit** button to open the Current Object's specification dialog. Changes made here affect all objects generated within the region. See "Specification Dialogs" on page 23.
- Check **Show Objects** to display the distributed objects in floor plan view.
- Check **Show Region** to display the edges of the distribution region in floor plan view.

2 Object Spacing - Specify how the objects in the region are spaced.

- Specify the **Distance** between the objects in the region, as measured from their center points.
- Select **Standard Grid** to position the objects in rows and columns based on the standard X/Y grid in the program.
- Select **Alternate Grid** to position the objects in rows and columns based on the shape of the region.

3 Object Orientation - Specify how or if the objects in the region are rotated.

These settings do not affect the region itself or its edges.

- Specify the **Angle** that the distributed objects should be placed at.
- Select **Absolute Angle** to rotate the objects to the specified Angle as measured from an imaginary horizontal line drawn from the origin towards the right.
- Select **Relative Angle** to rotate the objects relative to the angle of the region's first edge or, if that edge is curved, to the angle of its chord. The first edge is typically located at the top of the

region when it is first created; however, this can change as the region is edited.

- Select **Random Angle** to rotate the objects in the region at a variety of random angles.

4 Object Positioning - Specify the positioning of the distributed objects relative to a point of origin within the region.

- Specify the **X Offset**, the horizontal distance in floor plan view from the region's specified point of origin.
- Specify the **Y Offset**, the vertical distance in floor plan view from the region's specified point of origin.
- Select **From Polyline Center** to measure the offset from the region's center point.
- Select **Polyline Start** to measure the offset from the region's start point. This start point is typically located at the top left of the region when it is first created; however, this can change as the region is edited.

Polyline Tab

The Polyline tab indicates the polyline's **Length/Perimeter**, its enclosed **Area**, and the **Volume** of a closed polyline.

Selected Line Tab

The Selected Line tab is available when the selected edge of the Terrain Perimeter is a line as opposed to an arc. See "Selected Edge" on page 71.

The settings on this tab are available for a variety of other objects in the program. For information about these settings, see "Selected Line Tab" on page 222.

Selected Arc Tab

The Selected Arc tab is available when the selected segment of the polyline is an arc as opposed to a line. See “Change Line/Arc” on page 92.

The settings on this tab are available for a variety of other objects in the program. For information about these settings, see “Selected Arc Tab” on page 223.

Line Style Tab

The settings on the Line Style tab are available for a variety of other objects in the

program. For information about these settings, see “Line Style Tab” on page 225.

Fill Style Tab

The settings on the Fill Style tab affect the appearance of the selected object in floor plan view. For information about these settings, see “Fill Style Tab” on page 225.

Materials Tab

The settings on the Materials tab affect the appearance of the selected object in 3D views. See “Materials Tab” on page 303.

Garden Bed Specification Dialog



To open the **Garden Bed Specification** dialog, select a Garden Bed and click the **Open Object** edit button or double-click the Garden Bed using the **Select Objects**  tool.

Because a Garden Bed is a type of terrain feature, the settings in this dialog are essentially the same as those in the **Terrain Feature Specification** dialog. See “Terrain Feature Specification Dialog” on page 265.

Terrain Path Specification Dialog



To open the **Terrain Path Specification** dialog, select a Sidewalk and click the **Open Object** edit button or double-click the Sidewalk using the **Select Objects**  tool.

Most of the tabs in this dialog are similar to those for a variety of other objects in the program.

General Tab

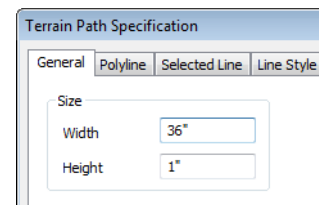

Enter the **Width** of the object and the **Height**. If you enter a negative number for the height, the object sinks into the terrain.

Polyline Tab

The Polyline tab indicates the Terrain Path polyline's **Length/Perimeter**, its enclosed **Area**, and the **Volume** of a closed polyline.

Selected Line Tab

The Selected Line tab is available when the selected edge of the Terrain Perimeter is a line as opposed to an arc. See "Selected Edge" on page 71.

The settings on this tab are available for a variety of other objects in the program. For information about these settings, see "Selected Line Tab" on page 222.

Selected Arc Tab

The Selected Arc tab is available when the selected segment of the polyline is an arc as opposed to a line. See "Break Line" on page 92.

The settings on this tab are available for a variety of other objects in the program. For

information about these settings, see "Selected Arc Tab" on page 223.

Line Style Tab

The settings on the Line Style tab are available for a variety of other objects in the program. For information about these settings, see "Line Style Tab" on page 225.

Fill Style Tab

The settings on the Fill Style tab affect the appearance of the selected object in floor plan view. For information about these settings, see "Fill Style Tab" on page 225.

Materials Tab

The settings on the Materials tab affect the appearance of the selected object in 3D views. See "Materials Tab" on page 303.

Plants



Home Designer Essentials's Library Browser features a Plants category with a selection of plant, shrub and tree images which you can place in your plan. See "The Library" on page 282.

Once placed in your plan, these plant images can be selected, moved, copied and resized to produce a wide variety of unique landscaping designs. See "Editing Images" on page 373.

Plant Image Specification Dialog



Select a plant in a floor plan or 3D view and click the **Open Object** edit

button to open the **Plant Image Specification** dialog.

Image Tab

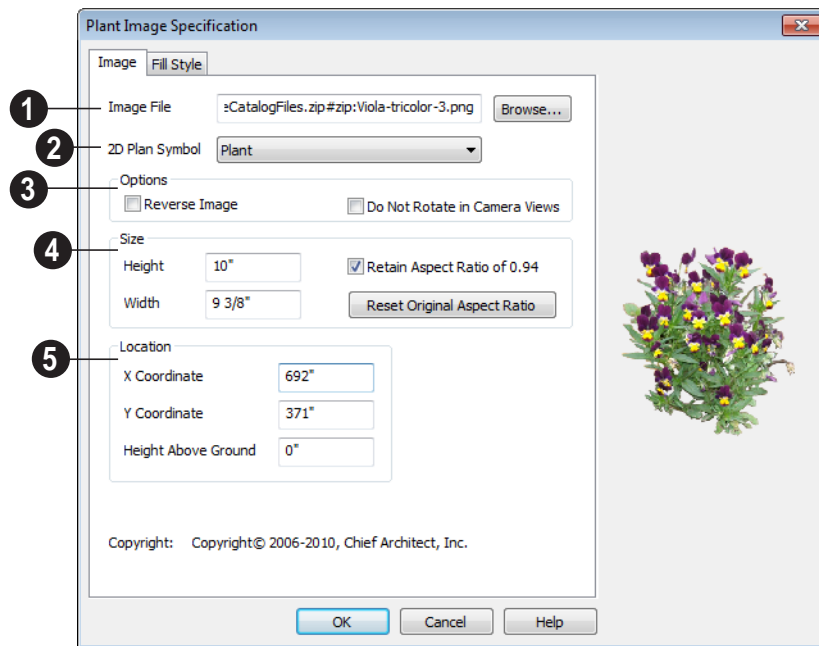

- 1 **Image File** - The path and name of the selected image file displays here. Click **Browse** to specify the saved location on your computer of the image that represents the plant in 3D views.
- 2 A number of **2D Plant Symbols** are available to mark the location of the image in floor plan view. Select one from the drop-down list.
- 3 **Options**
 - Check **Reverse Image** to reflect the appearance of the image about an imaginary vertical line through its center.
 - Check **Do not rotate in 3D view** to prevent the plant image from rotating with the camera.
- 4 Specify the **Size** of the plant image, as seen in 3D views.
 - Enter a **Height** for the image.
 - Enter a **Width** for the image.
 - When **Retain Aspect Ratio of** is checked, if you change either the Height or Width, the other value changes to maintain this ratio. If this is unchecked and you resize the plant image, it may become distorted.
 - Click **Reset Original Aspect Ratio of** to reset the image's original aspect ratio and remove any distortion caused by resizing.
- 5 Specify the **Location** of the selected plant image.
 - Precisely position the selected plant image in reference to the plan coordinates

by specifying its **X Coordinate** and **Y Coordinate**.

- Specify the selected plant image's **Height Above Ground**.

Fill Style Tab

The Fill Style tab controls the appearance of the selected plant's 2D Plant Symbol in floor plan view. By default, plant images' fill style

is None (Transparent). For information about the settings on this tab, see "Fill Style Tab" on page 17.

If the plant's 2D Plan Symbol does not form a closed shape, the settings on the Fill Style tab will have no effect on the appearance of the plant in floor plan view.

Sidewalks, Driveways & Parking Lots

Sidewalks, driveways and parking lots are modeled in 3D like other terrain objects in Home Designer Essentials. Because they have much in common with terrain objects and rely upon terrain data to be viewed in 3D, it is helpful to be familiar with terrain modeling before using these tools. See “Terrain” on page 258.

Chapter Contents

- Road Tools
- Displaying Road Objects
- Editing Road Objects

Road Tools

Sidewalks, driveways and parking lots can be drawn in floor plan view, camera views and overviews, but only when a Terrain Perimeter exists in the plan. See “Terrain Perimeter” on page 258.

Sidewalks have a consistent width that can be defined in their specification dialog. See “Terrain Feature Specification Dialog” on page 265 and “Terrain Path Specification Dialog” on page 268.

Driveways and Parking Lots are actually Terrain Features. See “Terrain Feature Tools” on page 260. They are drawn as rectangles but can be edited to any shape. See “Editing Closed-Polyline Based Objects” on page 80.

Once road objects have been placed, they can be edited individually or as a group. See “Editing Road Objects” on page 274.

Straight Sidewalk



To create a sidewalk, select **Terrain> Road and Sidewalk> Straight Sidewalk**, then click and drag from end to end to draw a line. The ends of multiple sidewalk sections can be connected together.

Sidewalks are edited along their center line like line- and polyline- based objects. See “Editing Line Based Objects” on page 73.

Sidewalks can be edited in their specification dialog. See “Terrain Path Specification Dialog” on page 268.

Driveway Area



A **Driveway Area** is a terrain feature with a concrete material assignment. To create a driveway, select **Terrain> Road and Sidewalk> Driveway Area**, then click and drag from corner to corner to draw a rectangle.

Height, thickness and material information can be specified in a driveway’s specification dialog. See “Terrain Feature Specification Dialog” on page 265.

Driveways can be edited like other closed polylines. See “Editing Closed-Polyline Based Objects” on page 80.

Parking Lot



A **Parking Lot** is a terrain feature with an asphalt material assignment. To place a parking lot, select **Terrain> Road and Sidewalk> Parking Lot**, then click and drag from corner to corner to draw a rectangle.

Height, thickness and material information can be specified in a parking lot’s specification dialog. See “Terrain Feature Specification Dialog” on page 265.

Displaying Road Objects



Sidewalks, driveways and parking lots display in floor plan and 3D views

based on the settings in the **Display Options** dialog. See “Layers” on page 58.

In 3D Views

Road objects display in 3D views within the Terrain Perimeter. If the display of the Terrain Perimeter is turned off in 3D views, sidewalks, driveways and parking lots will not display, either: even if their layers are turned on.

By default, terrain rebuilds automatically when road objects are added, removed or edited. If it does not, you can select **Terrain>**



Build Terrain . See “Terrain Perimeter” on page 258.

Editing Road Objects

Road objects can be selected in 2D and 3D views and edited using the edit handles, the edit toolbar and their specification dialogs.

Using the Mouse

The edit handles available for a selected road object depend on the type of object selected.

- **Sidewalks**  are edited along their centerline like a line or open polyline. See “Editing Line Based Objects” on page 73.
- **Driveway Areas**  and **Parking Lots**  are edited like other closed polyline based objects. See “Editing Closed-Polyline Based Objects” on page 80.

In the Specification Dialog

 Road objects can be customized in their specification dialogs. See “Terrain Feature Specification Dialog” on page 265 and “Terrain Path Specification Dialog” on page 268.

Using the Edit Tools

A selected road object can be edited in a variety of ways using the buttons on the edit toolbar. See “The Edit Toolbar” on page 21.

Other Objects

Home Designer Essentials has additional objects that can be used to customize your design.

Chapter Contents

- General Shapes
- Soffits
- Special Applications for Soffits
- Calculating Materials on Soffits
- Soffit Specification Dialog

General Shapes

Items in the Home Designer Core Catalogs> Shapes library catalog allow you to create a variety of custom objects using basic geometric shapes. These shapes can be

used individually or combined to create a wide variety of custom objects.

General Shape objects are placed and edited much like other library objects. See “Editing Box-Based Objects” on page 82.

Soffits



Soffits typically fill the space between the tops of wall cabinets and the ceiling, but they are very versatile and can be used to create almost any other object that can be modeled as a 3D box. Select **Build> Cabinet> Soffit** to activate this tool.

Soffit Defaults

The default settings for soffits are set in the **Soffit Defaults** dialog. The settings in this dialog are similar to those in the **Soffit Specification** dialog. See “Soffit Specification Dialog” on page 279.

For best results when placing soffits above wall cabinets:

- The default soffit should be the same width as and 1" (20mm) deeper than the default wall cabinet. See "Cabinet Defaults" on page 242.
- The default soffit **Floor to Bottom** value should equal the sum of the default wall cabinet's Floor to Bottom value plus its Height. See "General Tab" on page 280.
- The default soffit **Height** should be equal to or greater than the space between the ceiling and the top of the wall cabinets.

If the sum of the default soffit's Floor to Bottom value and Height is larger than the ceiling height of the room in which a soffit is placed, the Floor to Bottom value will be retained and its Height will be adjusted so that it fits under the ceiling.

The maximum soffit width is 250 feet (48m), and the minimum width is 1/16" (1 mm).

Once a soffit is placed in a plan, you can change its size and position to meet a variety of needs.

Placing Soffits

Soffits can be created in both 2D and 3D views by simply clicking with the **Soffit**  tool active. See "Click-to-Create" on page 65.

They can be assigned materials that are calculated in the Materials List, but by default they use the material assigned to the default wall. See "Wall Defaults" on page 97.

When positioned against a wall in a room, soffits will display any moldings present in that room that are at the same height as the soffit. See "Moldings Tab" on page 134.

To create a corner soffit, click as close to an inside wall corner as possible. A corner soffit retains its shape when it is moved, edited, or copied.

When a soffit is created, it is placed on the "Cabinets, Soffits" layer. See "Displaying Objects" on page 59.

Special Applications for Soffits

Nearly any object with straight, flat sides can be represented by one or more Soffits. They can be resized to as small as 1/16" (1mm) per side, or as large as 250 feet (48m).

Soffits can have materials applied to them to represent simple mirrors, posts, chimneys and so on. Following are some additional examples.

Coffered Ceilings

Soffits can be used to create coffered ceilings. When placed against a wall, a soffit will display any moldings assigned to the room it is in that are at its height.



Accent Tile Surrounds

A material such as ceramic tile can be assigned to one or more soffits applied to the walls above tubs or in showers.



Masonry Veneer

You can use a soffit to create a brick or stone veneer over part of a wall. Specify a soffit depth equal to the masonry material to be used.



Soffits automatically stop at the floor platform when moved downward or at the ceiling platform when moved upward - even when the soffit is not located in a room. To more or resize a soffit through a floor or ceiling platform, select it and hold the Ctrl key down while dragging its edit handles. See “Unrestricted Movement” on page 88.

Calculating Materials on Soffits

The number of bricks, tiles, shingles, shakes or other materials applied to a soffit is

calculated using the following rules:

- If the soffit depth is less than the larger of 4 inches (10 mm) or 1 ½ times the material thickness, then only the front area of the soffit is used. Thus if a soffit is 48"x48"x4" thick, and the Dark Red brick material is used (3"x 8" with 3/8" mortar joint) the front of the soffit is 48"x48"=2304 square inches. Including the mortar joint, each brick requires $3 \frac{3}{8}'' \times 8 \frac{3}{8}'' = 28.26$ square inches. 2304 sq. in. divided by 28.26 sq. in. per brick gives 81.5 bricks.
- If the soffit depth is greater than both 4 inches (10 mm) and 1 ½ times the material thickness, then the surface areas of the soffit back, sides and top are used in addition to the front, if these surfaces are not attached to a wall or other soffit. However, only those portions of the sides, top and bottom remaining after subtracting twice the material thickness are used. So, for Dark Red brick, which has a depth of 4", the sides, top and bottom surface areas cannot contribute to the brick count unless the soffit depth is greater than 8 inches.
- If surface materials such as brick are applied to a large soffit, the soffit center is assumed to be hollow, with only a single layer of the material applied to each applicable face.
- For shingles and shakes, the overlap amount should be subtracted from the height, as opposed to brick or tile, where the joint width is added to the size.
- For materials in the area category, the soffit area calculation above is used, with the material thickness treated as zero.
- For materials in the volume, concrete or earth categories, the true volume of the soffit is used.

Soffit Specification Dialog



To customize a soffit using the **Soffit Specification** dialog, double-click on the soffit using the **Soffit**  tool or select the soffit and click the **Open Object** edit button.

The settings in this dialog are similar to those in the **Soffit Defaults** dialog, but affect only the selected object(s).

General Tab

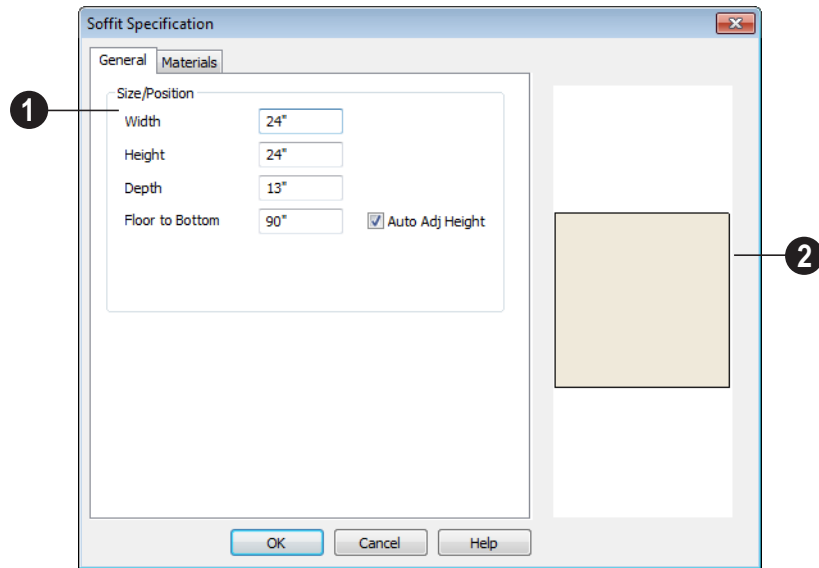

- 1** Define the **Size** and **Position** of the selected soffit relative to the floor or terrain.
- Specify the **Width** of the soffit.
 - Define the vertical **Height** of the soffit.
 - **Depth** - Define the distance between the front and the back of the soffit. When selected in floor plan view, the front of a soffit has a “V,” and the back of the soffit has a triangular rotation handle.
 - If the selected soffit is a corner soffit, the **Width** controls its left side width, and **Depth** controls its right side width.
 - **Floor to Bottom** - Specify the distance from the bottom of the soffit to the floor. This is sometimes more easily done by positioning the soffit in a 3D view.

- When the selected soffit is outside a room and **Auto Adjust Height** is checked, its **Floor to Bottom** height is measured relative to the terrain height. When this is unchecked, the **Floor to Bottom** height is measured from the default floor height of Floor 1. See “Terrain Height vs Floor Height” on page 259 of the Reference Manual.

- 2** A preview of the soffit displays on the right side of the dialog box.

Materials Tab

For information about the settings on this tab, see “Materials Tab” on page 303.

The Library

Home Designer Essentials's library offers thousands of symbols, materials, and images that can enhance any plan.



Chapter Contents

- The Library Browser
- Searching the Library
- Library Content
- Downloading Library Content
- Importing Library Catalogs
- Adding Library Content
- Organizing the Library
- Exporting Library Catalogs
- Placing Library Objects
- Select Library Object Dialog
- Displaying Library Objects
- Editing Library Objects
- Symbol Object Specification Dialogs

The Library Browser

 The Home Designer Essentials Library Browser allows you to manage the contents of the library as well as add library content to your drawings.

To open the Library Browser:

- Select **Library > Library Browser** .
- Click the **Library Browser** button .
- Press **Ctrl + L** on your keyboard.

By default, the Library Browser is docked to the right side of the program window, but can be undocked or docked to another side. See “Docking the Library Browser” on page 286.

The Library Browser has four sections:

- The search options at the top.
- The Directory and Search Results Pane.
- The Selection Pane.
- The Preview Pane.

To adjust the height or width of a section, place the pointer over the split bar you want to move. When the double-headed arrow \leftrightarrow displays, click and drag.





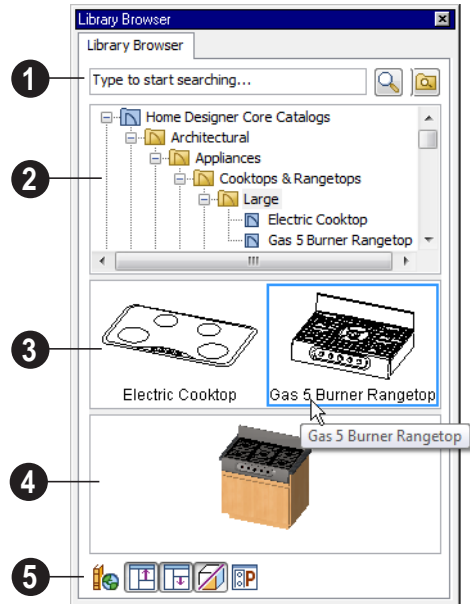

You can control the configuration of the Library Browser panes in the Preferences dialog. See “Library Browser Panel” on page 51.

You can work on your drawing with the Library Browser open. To close the Browser, click the Close  button or double-click on an object in the Selection Pane.



The library has three categories: Home Designer Core Catalogs, User Catalog and Trash. See “Library Content” on page 287.

- 1** Search the library using keywords and optional search filters. See “Searching the Library” on page 286.
 - Begin typing in the text field to search for library items. As you type, search results will display in the Directory Pane.
 - Right-click on an item in the Search Results list and select **Show in Browser** to view the item’s location in the Directory list.
 - Click the **Browse**  button to stop searching and restore the Directory list.

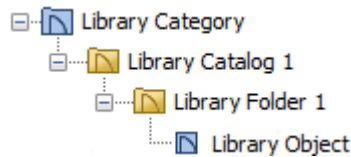

- Click the **Search**  button to display the search results for your search entry.
- Click the **Turn On Search Filtering**  button to display the search filtering options and customize your search parameters.
- Click the **Turn Off Search Filtering**  button to display the search filtering options and customize your search parameters.

2 The library **Directory** and **Search Results** display here. The basic structure of the directory tree is:



Library items are always placed in alphabetical order within their hierarchy.

The Library Browser includes a Trash bin, where deleted items are moved until you choose to Empty Trash. See “Deleting Library Items” on page 292.

Navigate the Directory Pane using the mouse. Click the  beside a catalog or folder to display its contents. Once expanded, you can click the  beside it to close it again. You can also scroll the list using the arrow keys on your keyboard.

Click on an item to select it. Preview images display in the Selection and Preview Panes and basic information about it also displays in the program’s Status Bar. See “The Status Bar” on page 23.

3 The **Selection Pane** shows a thumbnail image of the item selected in the Directory Pane.

When an item is selected in the Directory Pane, a basic line-based representation of the item displays in the Selection Pane.

- If the selected item is a single object, a preview of that object displays in the Preview Pane. You can move your cursor into the drawing area to place the item. See “Placing Library Objects” on page 293.
- If the selected item is a folder, a thumbnail image displays, representing each item inside. Move your pointer over an item in this pane to see a Tool Tip with the item’s name. Click on a folder in the Selection Pane to display its contents here and make it the item selected in the Directory Pane.
- Some folders may have too many items to display useful thumbnails for each; when this is the case, they do not display.

Click the **Show/Hide Selection Pane** button to toggle the Selection Pane on and off.

4 When an individual object is selected in either the Directory or Selection Pane, an image of it displays in the **Preview Pane**.

You can click the **Toggle Display** button at the bottom of the browser window to switch between preview images in high and low detail.

If the selected object is a 3D symbol, you can rotate and zoom in or out on the Preview using the mouse.

If you have rotated a view in the Preview Pane, you can restore the default angle either by clicking in the Selection Pane or by right-

clicking on the Preview Pane and selecting **Reset Preview**.

Click the **Show/Hide Preview Pane** button to toggle the Preview Pane on and off.

5 The toolbar at the bottom of the browser aids in searching, displaying panes, and managing library content.



Click the **Get Additional Online Content** button to launch your default web browser to the Home Designer Essentials web site, where additional library content is available for download.



Click the **Show/Hide Selection Pane** button to toggle the Selection Pane on and off.



Click the **Show/Hide Preview Pane** button to toggle the Preview Pane on and off.



Click the **Toggle Display** button to switch between high and low detail images of a selected library object in the Preview Pane.



Click the **Preferences** button at the bottom of the Library Browser to open the **Preferences** dialog, where display properties for the Library Browser can be controlled. See “Library Browser Panel” on page 51.

Using the Contextual Menus

A number of important library functions can be accessed using the contextual menus. Right-click on an item in the Library Browser to open a contextual menu displaying options related to that item. See Contextual Menus.

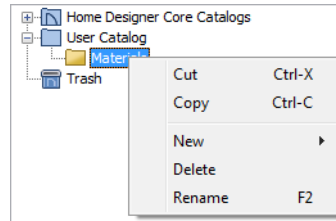

The options in the contextual menu vary depending on the item selected, but may include:

- Cut/Copy/Paste
- Paste Shortcut
- Rename
- Delete
- Export Library
- Open
- Reset Preview
- Expand All/Collapse All
- Show in Browser

Keyboard Commands

The Library Browser can be navigated using the arrow keys on your keyboard.

- The right and left arrow keys expand and collapse folders.
- The up and down keys change which library object is currently selected.
- Select an item and press F2 to rename it.
- Select an item and press the Delete key to delete it.

Expand/Collapse All

When a library category or folder is selected in the Directory Pane, **Expand All** and **Collapse All** are available in the contextual

menu, allowing you to expand or contract its contents in the tree view.

Docking the Library Browser

Initially, the Library Browser is docked to the right side of the Home Designer Essentials program window.

To undock the browser window, double-click the striped grab bar. You can also undock it by clicking on the grab bar and dragging it into the center of the program window.

Once undocked, the Library Browser can be moved by clicking and dragging the title bar.

When moved to the top, bottom, or side of your screen, it automatically docks in a vertical or horizontal orientation, depending on its location.

- Holding down the **Ctrl** key prevents the Library Browser from docking while moving.

- If you close the program with the Library Browser docked, it displays in the same position the next time the program is opened.

To return the browser window to its original position and size, click the **Restore Position/Size** button on the Library Browser Panel of the **Preferences** dialog. See “Library Browser Panel” on page 51.

Closing the Library Browser

The Library Browser can be closed in either of two ways:

- Click the **Close**  button at the top right corner of the browser window.
- Select **Library > Close Library Browser** .

Searching the Library

The Library Browser filtering options let you focus your searches to meet parameters that you define.

To search the Library Browser



1. Select **Library > Library Browser**  and click in the Search field at the top of the Library Browser.
2. Begin typing a keyword to search for.
3. As you type, the search results will populate in the Directory Pane below.

4. If you move your mouse pointer over the Search field, a Tool Tip will state the number of results of your search.
5. Right-click on an item in the Search Results list and select **Show in Browser** to view the item’s location in the Directory list.

Substrings are not included. For example, searching for “windows” will not produce “window” as a search result. On the other hand, searching for “window” will produce “windows” as a search result.

To search using custom filters

1. Click the **Turn on search filtering options**  button.
 - Check **Match Keyword** to match the entered search keyword with an object's search attributes.
 - Check **Match Entire Word** to match the entire keyword or words with the complete name of the object.
 - Check **Match Folders** to include library folders in your search.
2. Check **Filter by** to enable additional filtering options, which display below.
3. Select a filtering option from the drop-down list on the left, then choose what to include in the filter from the drop-down list on the right:
 - Select **Type**, then select a category of library item to include in your search.

- Select **Style**, then choose a design style to restrict the search results to objects of that style.
 - Select **Manufacturer**, then choose the name of a manufacturer to include in your search.
4. Multiple filters can be created and used at the same time:
 - Click the **Add**  button to the right of a filter to make copy of that filter.
 - Specify a new **Type**, **Style**, and/or **Manufacturer** for the new filter.
 - Click the **Delete**  button to the right of a filter to remove that filter.

Note: Your custom search settings are not retained when you end the current program session.

Library Content

The Home Designer Essentials library has three categories: Home Designer Core Catalogs, User Catalog and Trash. See Getting Started Guide, “Deleting Library Items” on page 292.

Home Designer Core Catalogs

The Home Designer Core Catalogs category contains a wide selection of 3D symbols, images, and materials. When you install the program from DVD, this library content will also be installed; if you download the software, you will be able to download the Core Catalogs separately, after the program is installed.

When you launch the program for the first time, it will ask if you want to download the Core Catalogs. Click Yes to begin the download. If you click No, you can download at any time by selecting **Library> Install Core Content** from the menu.

Home Designer Bonus Catalogs

Chief Architect regularly posts new library catalogs available for download. Select **Library> Get Additional Content**

Online  from the menu to access the bonus catalogs and content.

The User Catalog

The User Catalog is the location for items that you add to the library. See “Adding Library Content” on page 290.

You can create and organize custom library folders and imported images, backdrops, and materials. See “Organizing the Library” on page 291.

Updating Library Catalogs

The Home Designer Core Catalogs and Bonus Catalogs are updated periodically to include new and improved content. You can update your installed catalogs to include the latest content by selecting **Library > Update Library Catalogs** at any time.

The program will gather information about the content in each of these two categories, and then download and replace any content that is not up to date, and you may see a progress indicator at the bottom of the Library Browser while it is doing so. See “Download Progress” on page 289.

Backing up Library Content

The Home Designer Essentials User Catalog File, `User_Library.calib`, is located in the

Home Designer Essentials 2014 Data folder. See “Home Designer Essentials Data” on page 32.

The best way to back up your custom library content is to export the items in your User Catalog, as this will ensure that the textures used by custom materials are not lost. See “Backing Up Your Files” on page 35.

Exported libraries use the **.calibz** file format: a zipped file type that can include textures and images along with other library data.

To back up your custom library content

1. Launch Home Designer Essentials and select **Library > Library Browser**  from the menu.
2. Right-click on a folder or item in the User Catalog.
3. Select **Export Library** from the contextual menu.
4. The **Export Library Data** dialog is a typical Save dialog. See “Exporting Files” on page 34.
 - Notice that the file type in the Save as type field is “Library File with Textures/Images (*.calibz)”.

Downloading Library Content

Core Catalogs

When you launch Home Designer Essentials for the first time, you will be asked if you want to download the Core Catalogs. Click Yes to begin the download.

If you click No, you can download at any time by selecting **Library > Install Core Content** from the menu.

Bonus Catalogs

BonusCatalogs can be downloaded from our web site,

www.homedesignersoftware.com. Select **Library > Get Additional Content**

Online  to launch your default internet browser to our Content Resources page.

Download Progress

When library content is downloading, a green progress bar will display at the bottom of the Library Browser. If you choose to download the Core Catalogs while the library is not open, the Browser will open so the progress indicator can display.

Click on the progress bar to display the name of the current file being downloaded, the total amount of data to be downloaded in KB, and the amount downloaded so far.

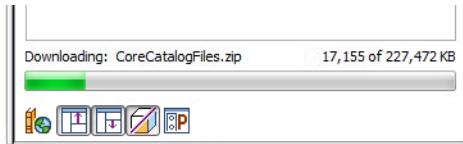

Pausing and Resuming

Library downloads can only take place while Home Designer Essentials is running. If you close the program while a download is in

progress, a dialog will confirm whether you wish to stop the download.

- Click **Stop Download and Close Program** to stop the download and close the program.
- Click **Cancel** to leave the program open and continue downloading.

Most catalogs are composed of a single file. If you stop the download midway, none of the downloaded data will be retained.

The Core Catalogs, on the other hand, contain a large volume of data saved in multiple files. If you close the program and stop the Core Catalogs download midway, only data associated with the file currently being downloaded will be lost. You can resume the download beginning with that file at a later time by selecting **Library > Install Core Content**.

Download Errors

If any problems occur during the library download process, a dialog box will notify you at the end of the download. Click **Retry Download** to repeat the download and correct any errors or click **Cancel** to discard the downloaded catalog.

Importing Library Catalogs

Home Designer Essentials library files have two different file extensions: **.calib** and **.calibz**. Both files can include any combination of Home Designer Essentials library items; in addition, **.calibz** files are able to save data associated with textures and images. Both file types can be imported into the Home Designer Essentials library.

There are several ways to import a **.calib** or **.calibz** file into the program library:

- Double-click on the file in Windows Explorer.
- Drag the file from a Windows Explorer window and drop it into the Home Designer Essentials program window.

- Select **Library> Import Library** from the program menu.

To import library files into the library

1. Select **Library> Import Library** to display the **Import Library Data** dialog.
2. Browse to the **.calib** or **.calibz** file that you want to import and select the files so that its name displays in the **File Name** field.
3. Click the **Open** button.

4. A progress bar will display, telling you the progress of each library data file as it is imported. Once imported, each file will be located in the User Catalog.

When a **.calib** or **.calibz** file is imported into the program, its contents are automatically placed in the User Catalog. Any images or textures saved in a **.calibz** file will be copied into the Home Designer Essentials 2014 Data\Images and Textures folders for backup purposes. The program will only reference these copies if it cannot locate the files in their original locations. See “Home Designer Essentials Data” on page 32.

Adding Library Content

In addition to downloading Home Designer Essentials Content and importing entire catalogs into the library, you can also add a variety of individual objects to the library.

Add to Library

Nearly any object placed from the Library Browser can be added to the User Catalog in the library. Select an object in your plan and click the **Add to Library**  edit button.

In addition, some Home Designer Essentials objects that are not symbols, such as cabinets, terrain objects,, windows, and doorways can be added to the library.

An object created using a drawing tool in Home Designer Essentials will automatically be added to the User Catalog using the name of that tool. These objects can be renamed after adding them to the Library, either before or after moving them to their appro-

priate user created folder in the User Catalog. See “Renaming Library Items” on page 291.

Adding Materials and Images

New materials and images can be created in the User Catalog. Right-click on the User Catalog or a folder within it, select **New>** from the contextual menu, then select the type of item you wish to create from the submenu.

Home Designer Essentials can use materials and images in a variety of file formats and provides several means of adding new material and image files to the library. For more information, see “Creating Materials” on page 305 and “To create an image in the Library Browser” on page 372.

Adding New Backdrops

Backdrops are images that display behind the model in 3D views. See “3D Backdrops” on page 324.

To add a backdrop to the library

1. Select **File> Import> Backdrop**  to open the **Import Backdrop File** dialog, which is similar to the **Import Picture File** dialog. See “Importing Pictures” on page 375.

2. Browse to an image file on your computer, select it, and click **Open**. This backdrop can now be found in the My Backdrops library.

You can also create a new backdrop by copying and pasting an image into Home Designer Essentials. See “Copying and Pasting Objects” on page 66.

Organizing the Library

Library folders and objects can be copied, pasted, moved, and deleted: allowing you to organize your User Catalog to best suit your work style and needs.

Adding New Folders

New folders can be added to the User Catalog or to any folder located within it. To add a new folder, right-click on User Catalog or one of its sub-folders and select **New> Folder** from the contextual menu.

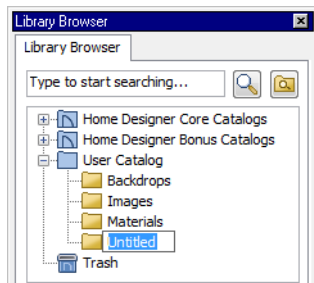

The new folder is created inside the library item you right-clicked on and is initially named “Untitled”. Type a short, descriptive name and press Enter.

Selecting Library Items

To select a library object, folder, or category, simply click on it.

When an item is selected, preview images display in the Selection and Preview Panes and basic information about it also displays in the program’s Status Bar. See “The Status Bar” on page 23.

A selected library item can be modified in a number of ways to help meet your organizational needs.

Renaming Library Items

Only folders and objects in the User Catalog can be renamed. There are several ways to do this from the tree list:

- Right-click on the item, select **Rename** from the contextual menu, and type a new name.
- Click once on the item, press F2 on your keyboard and type a new name.
- Click once on the item, pause for a moment, then click a second time and type a new name.

Library names are case-sensitive and can contain up to 63 characters. While you can

have more than one library item that uses the same name, it is best to use short, descriptive and unique names.

Moving Library Items

Folders and objects in the User Catalog can be moved to new locations within the User Catalog. Folders and library objects are always organized alphabetically within each hierarchy.

To move an item to a different location, select it in the tree list, then click and drag it to the new location in the list. Directories and folders able to accept new content highlight as your mouse pointer moves over them. Release the mouse button to relocate the selected library item in the highlighted location.

Copying Library Items

All library folders and library objects can be copied and pasted to new locations in the User Catalog.

There are two ways to copy a library item to the Windows Clipboard:

- Right-click on it and select **Copy** from the contextual menu.
- Click on the library item and press **Ctrl + C** on your keyboard.

To **Paste** the item, click on a library catalog or folder in the Library Browser tree view and either:

- Right-click on the new location and select **Paste** from the contextual menu.
- Press **Ctrl + V** on your keyboard.

When a library item is copied and pasted, the new item that results is independent of the

original item. If you make changes to it, the original item is unaffected. Similarly, changes to the original item do not affect the copy.

Library Shortcuts

In addition to copying and pasting to create new, independent library items, you can copy and paste to create Library Shortcuts. Library Shortcuts are not independent items - they are linked to the original item and are affected if changes are made to the original.

Library Shortcuts are advantageous because you can place a given library item in multiple locations to suit your organizational style without increasing the size of the library database and without having to maintain multiple copies of the same item.

To create a Library Shortcut, copy a library item to the Windows Clipboard. Then, right-click on the location where you would like to create a copy and select **Paste Shortcut** from the contextual menu. Library Shortcuts use the same name as their source item but use the Library Shortcut  icon.

To locate a Library Shortcut's source item, right-click on it in the tree list and select **Locate Shortcut Source**

If you move or delete an item from the library, any shortcuts to it will not be updated or removed. If you try to use a "hanging" shortcut, a message about its status will display in the library preview panes.

Deleting Library Items

The three installed library categories: Home Designer Core Catalogs, User Catalog, and Trash cannot be deleted.

Individual subfolders and objects can be deleted out of the User Catalog in either of two ways:

- Right-click on it and choose **Delete** from the contextual menu.
- Select it and press the **Delete** key on your keyboard.

When items from the User Catalog are deleted, they are moved to the Library

Browser Trash . Items in the Trash can be retrieved by clicking and dragging them into any location in the User Catalog.

To empty the Trash , right-click on it and select **Empty Trash** from the contextual menu.

Depending on how much content is in the Trash, emptying it can be time consuming. You can click the **Cancel** button to end the process if you wish.

 The Empty Trash command is both immediate and permanent. It cannot be undone, so use care when using it. You should back up all your library files regularly. See “Backing up Library Content” on page 288.

Exporting Library Catalogs

Exporting library files allows you to:

- Back up your custom library content.
- Transfer library content between computers.

Exporting is often preferable to simply copying library files because it allows you to include images and textures in the exported library.

To export content from the library

1. Locate an object, folder, or catalog that you want to export, right click on it, and select **Library> Export Library**.
2. In the **Export Library Data** dialog.

- Choose the appropriate **Save in:** location for your exported library file.
- Type a short, descriptive name for your library file in the **File Name** field.
- Click the **Save as type:** drop down list and select whether or not you want the library to include Textures/Images.

 If any of the items being exported are images or use textures, be sure to select the .calibz file type.

3. Click **Save**.
3. Your exported library file can now be copied to a network location or storage device in Windows Explorer.

Placing Library Objects

Library objects are subject to placement restrictions based upon typical real-life

placement. Most library objects require sufficient free space at the location where

they are placed, for example, and some library objects have additional requirements.

Library windows and doors, for example, must be placed in a wall just like standard windows and doors, and some fixtures are designed to be placed in cabinets.

If a warning message displays when placing a library object, it will indicate where the object can be placed.

There are three main categories of items available in the Library Browser:

- Stand-alone objects that can be placed directly into a plan. Examples include cabinet modules, furnishings and images.
- 3D objects designed to be inserted into another 3D object. Examples include cabinet fixtures, windows and doors. Some items, such as cabinet doors and fixtures and fence panels, can be inserted into another object or placed as stand-alone objects.
- Materials, which cannot stand alone and must be assigned or applied to another object.

Stand-Alone Objects

Most library categories contain objects that can be selected in the Library Browser and placed directly in a 2D or 3D view.

- Most stand-alone objects are designed to rest on the floor or terrain.
- Some objects will rest on top of a cabinet, shelf, furniture or roof plane object if one is located at the point where they are first placed.
- A few objects, notably some light fixtures, will mount on the bottom of a wall cabinet or on the ceiling.

- In addition, some objects will attach to a wall if one is nearby.

To place a stand alone library object

1. Click on an object in the tree view or Selection Pane of the Library Browser to select it for placement. See “The Library Browser” on page 283.
2. Move your cursor into the view area and notice that it displays an icon indicating the type of object selected instead of an arrow icon.
3. Click to place the selected object at that location.
4. Continue clicking to place as many instances of the selected object as needed. When you are finished, click the **Select Objects**  button.

Once a stand-alone object has been placed, it can be edited in a variety of ways. See “Editing Library Objects” on page 297.

Inserted Objects

Some objects cannot stand alone and must be placed into other objects in a plan. For example, doors and windows must be inserted into a wall, while some appliances and plumbing fixtures must be placed inside a base cabinet. See “Doors” on page 138, “Windows” on page 154 and “Cabinets” on page 242.

An inserted object can only display in a 2D or 3D view if the object that contains it is set to display. This is the case even if the inserted object’s layer is turned on. See “Displaying Library Objects” on page 296.

To insert a library object

1. Click on an object in the tree view or Selection Pane of the Library Browser to select it for placement. See “The Library Browser” on page 283.
2. Move your cursor into the drawing area.
3. Click on the object into which you wish to insert the selected library item. The library item is inserted into the object.
4. Continue clicking to place as many instances of the selected item as needed. When you are finished, click the **Select Objects**  button.

Assigned Items

Some library items, such as materials, are not objects in themselves but can be applied to objects in a variety of ways.

- Using the specification dialog of the containing object. See “Select Library Object Dialog” on page 295.
- By selecting the item in the library and then clicking on the containing object in floor plan view.
- Materials can be assigned to objects directly from the library in 3D views by selecting the material and then clicking on an object’s surface. See “The Material Painter” on page 301.

Select Library Object Dialog

The **Select Library Object** dialog is a modal version of the Library Browser that is accessible from object specification dialogs that display the  button. Click this button to select and apply items from the library to the object currently opened for specification. See “Specification Dialogs” on page 23.

The **Select Library Object** dialog only displays categories that are related to the opened object. For example, this is how the dialog looks when accessed from the General tab of the **Door Specification** dialog:

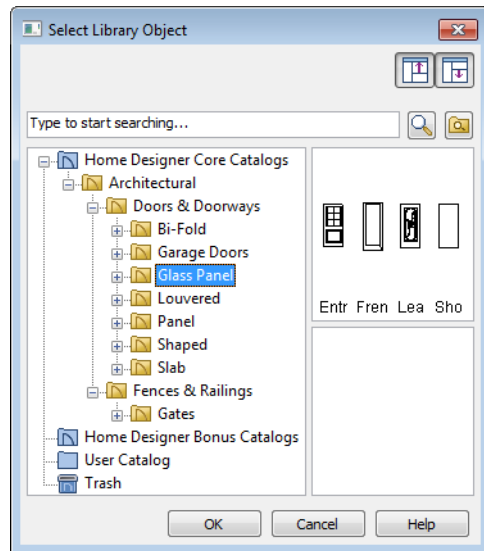

To make your selection, highlight the desired object and click **OK**, or simply double-click

on the object in the Selection Pane to close the **Select Library Object** dialog.

The **Select Library Object** dialog includes the search and search filtering options, can be resized \leftrightarrow , and can display the resizable Preview and Selection Panes.

If the **Select Library Object** dialog is opened by clicking the **Select Material** button on the Materials tab of any specification dialog or using the **Material Painter** , two additional options are available:

- Click the **Add New Material**  button to open the **Define Material** dialog and create a new material.
- Check **Use default material** to apply the default material for the selected object, if one exists. See “Material Defaults” on page 308.

See “Materials Tab” on page 303 or “The Material Painter” on page 301.

Displaying Library Objects

The display options available for library objects depend on the type of object in question, as well as the view.

If the display of an object is turned off in a 2D or 3D view, any objects inserted into it will not display in that view, either - even if the inserted object’s layer is turned on. See “Inserted Objects” on page 294.

In Floor Plan View

All library objects except materials, doors and drawers applied to cabinets, and backdrops can display in floor plan view. Library objects are represented in floor plan view by 2D symbols that resemble the size and shape of the object when viewed from above.

As with other architectural objects, the display of library objects is controlled by layer in the **Display Options** dialog. Each

library category has its own layer. See “Display Options Dialog” on page 60.

Object Labels

Fixtures, Furnishings, Geometric Shapes, Hardware, Millwork and Plants can display labels in floor plan view when the appropriate layer is set to display in the **Display Options** dialog. For example, fixture labels are placed on the “Fixtures, Labels” layer.

In 3D Views



All library objects can display in 3D views.

By default, images rotate to face the camera in 3D views. For information about turning off image rotation, see “Image Specification Dialog” on page 373.

Editing Library Objects

Library objects placed in a drawing can be selected individually or as a group, like other objects in Home Designer Essentials. See “Selecting Objects” on page 71.

Once selected, library objects can be edited in a variety of ways using the edit handles, the edit toolbar buttons and the specification dialog. See “Symbol Object Specification Dialogs” on page 297.

In Home Designer Essentials, objects created using the program’s standard tools, such as the **Door Tools**  and **Cabinet Tools** , are referred to as native objects.

On the other hand, objects placed from the library, such as fixtures and furnishings, are symbols. Symbols are typically more limited than native objects in how they can be edited.

Using Edit Handles

Most library symbols are box-based objects and can be edited as such once placed in a drawing. See “Editing Box-Based Objects” on page 82. Depending on the type of view and the surface selected, the edit handles a symbol displays will vary.

To resize Fixtures and Furniture, you must check **Fixture/Furniture Resize Enabled** in

the **Plan Defaults** dialog. When this option is checked, these library objects have edit handles when selected and can be resized like other objects. See “General Plan Defaults Dialog” on page 48.

When a furnishing or fixture symbol is selected in floor plan view or on the top surface in a 3D view, up to ten edit handles display. They are the Move handle at the center, the Rotate handle just outside the front indicator (a V) and a Resize handle on each edge and at each corner.

When a symbol is selected on a side in a 3D view, it displays five edit handles: the Move handle and a Resize handle on each edge.

Fixtures and furniture placed in a plan are subject to bumping/pushing behavior when moved. See “Bumping/Pushing” on page 88.

In the Specification Dialog

The specification dialog for any image, material, or plant image in the library can be edited from the Library Browser Directory Pane. See “Specification Dialogs” on page 23.

Specification dialogs are not available for native objects saved in the library.

Symbol Object Specification Dialogs



The **Fixture, Furniture, Geometric Shape** and **Millwork Specification** dialogs all feature the same options. The actual name of the dialog is determined by the type of object that is currently selected.

For example, selecting a library object placed from the Interiors Core Catalog and clicking the **Open Object**  edit button opens the **Furniture Specification** dialog.

General Tab

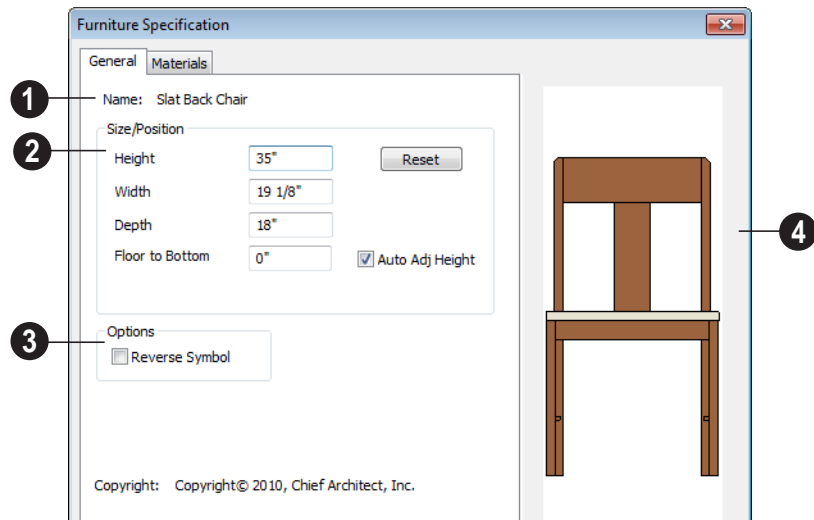

- 1 The **Name** of the selected object displays here.
- 2 **Specification** - Define the size and height above the floor of the object.
 - Specify the **Height, Width, and Depth** of the object.
 - **Floor to Bottom** - Enter the distance from the floor to the bottom of the object. A value of zero makes the object rest on the floor.
 - If the selected symbol is ceiling mounted, **Height Above Ceiling** will be available instead of Floor to Bottom. Specify the selected object's height above the ceiling. Enter a negative value to offset the symbol below the ceiling, or uncheck **Follow Ceiling** if you prefer to specify the object's Floor to Bottom height instead.
- 3 Check **Reverse Symbol** to reverse the object's appearance, so that features on its left are positioned on its right, and vice versa. This turns a right-hand refrigerator, for example, into a left-hand refrigerator. This option has no effect on objects that are symmetrical.
- 4 A preview of the library object displays here and updates with changes.
 - Click **Reset** to reset the symbol's original, unmodified size. The Floor to Bottom value is not affected by this button.
 - When the selected object is outside a room and **Auto Adjust Height** is checked, its Floor to Bottom height is measured relative to the terrain height. When this is unchecked, the Floor to Bottom height is measured from the default floor height of Floor 1. See "Terrain Height vs Floor Height" on page 259 of the Reference Manual.

Materials Tab

For information about the settings on this tab, see “Materials Tab” on page 303.

Materials

The objects used in Home Designer Essentials have a variety of 3D properties. These objects - walls, windows, doors, cabinets, roof planes, lot perimeters, etc. - can have materials assigned to them so that they look realistic in 3D views. These materials can also be used to generate materials lists that can help with cost estimations.

Designing with objects that look correct in 3D and calculate properly in the Materials List requires that you use realistic material definitions and apply them appropriately to objects in your plan.

Home Designer Essentials comes with many materials that are ready for use. From siding, roofing, flooring, masonry, tile, and paneling, to grass, water, and wood materials, Home Designer Essentials has materials for every application, inside and out. If you cannot find

a material that suits your needs, you can customize the materials provided or create your own.



Redefining only the visual properties of a material may create unexpected results. For example, changing the image of a brick material to represent siding does not cause the material to be considered as siding during material calculations.

Chapter Contents

- About Materials
- The Material Painter
- Materials Tab
- Editing Materials
- Creating Materials
- Define Material Dialog
- Material Defaults
- Color Chooser Dialog

About Materials

The materials that are assigned to objects in Home Designer Essentials perform two

important roles:

- They determine what the surfaces of objects look like in 3D views.
- They influence how objects are calculated in the Materials List. See “Materials Lists” on page 392.

Materials are stored in the Materials library in the Library Browser and can be applied to objects in either of two ways:

- Using the **Material Painter** .
- In an object’s specification dialog. See “Materials Tab” on page 303.

Textures

In Home Designer Essentials, materials have textures associated with them that determine how they look in 3D views.

Textures are created using special image files that tile seamlessly when applied to surfaces.

In 3D views, you can turn the display of textures on and off by selecting **3D> Render**

View Options> Toggle Textures . When textures are turned off, materials are represented using solid colors.

The Material Painter



Select **3D> Material Painter** to access the **Material Painter Tools**, which are used to apply materials to object surfaces in 3D views.

The **Material Painter**  tool can also be activated by selecting a material in the library while a 3D view is active.

Material Painter Modes

There are five Material Painter Modes. Each mode specifies how broadly or narrowly the selected material will be applied to surfaces in your plan.

- The **Material Painter Component Mode**  is the default mode. This applies the selected material to an object component. Using this tool is the same as opening an object for specification and changing the material for one of its components on the Materials tab. See “Materials Tab” on page 303.

- The **Material Painter Object Mode**  applies a material to all components of an object that share the same material assignment.
- The **Material Painter Room Mode**  applies a material to all the objects in the room that currently have the same material. For example, if you apply a material to a dining room chair, this mode applies the material to all other objects in the room with the same original material, such as other chairs and the dining table.
- The **Material Painter Floor Mode**  applies the selected material to all surfaces on the floor that currently have the same material. For example, if you apply a material to the kitchen countertops using this mode, the bathroom countertops on the same floor also have the material applied.
- The **Material Painter Plan Mode**  applies the selected material to all sur-

faces in the entire plan that currently have the same material. For example, if you have the same carpet on all floors in a plan, applying a selected material while this mode is active will change all carpet on all floors.

When the **Material Painter**  tool is active, the Material Painter Mode toolbar buttons display in the edit toolbar, allowing you to quickly change modes.



You can also specify the active mode by selecting **3D> Material Painter** . A check displays next to the active mode in the submenu.

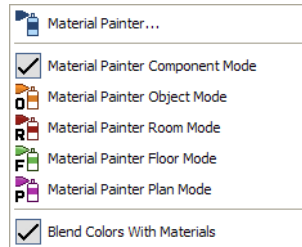



Blend Colors With Materials



 In addition to the Material Painter Modes, the **Blend Colors With Materials** option allows you to apply a solid color to a surface displaying a pattern and blend the two.



Blend Colors With Materials  works in all five Material Painter Modes. See “Blending Materials” on page 305.

To use the Material Painter tool

1. Create a 3D view in which the patterned material is visible.
2. Select **3D> Material Painter> Material Painter** .
3. Select a solid color material from the **Select Library Object** dialog. See “Select Library Object Dialog” on page 295.
 - Check **Use Default Material** at the bottom left of the dialog to apply the default material to any object that has a defaults dialog. See “Material Defaults” on page 308.
4. Select a Material Painter Mode from the edit toolbar, which displays on the left side of the program window when the Material Painter is enabled.
5. Click the **Blend Colors With Textures**  edit button to turn this feature on or off depending on your needs.
6. Note that the name of the material being painted displays on the left side of the Status Bar at the bottom of the program window. See “The Status Bar” on page 23.
 - Move your pointer over a surface in the 3D view. The Status Bar now states both the material being painted and the current material on the target surface.
7. Click on the surface to apply the selected material to that surface. The material is applied to surfaces in the model based on the active Material Painter Mode.
 - When both the **Material Painter**  and **Blend Colors With Textures** are

active, the cursor displays a paint roller icon .

- When the **Material Painter**  is active and **Blend Colors With Textures**  is not, the cursor displays a spray can icon .

8. If either the **Component**  or **Object Mode**  is active, you can continue to click on surfaces to apply the selected material. When you are finished, select a different tool.

Material Painter & Walls

As a general rule, the **Material Painter**  cannot be used to apply a material to an individual wall. Rather, it applies the material to an entire room, to all the rooms on the floor, or to all the rooms in the entire plan, depending on which Material Painter Mode is active.

There are a couple of exceptions to this rule that apply when the wall surface being painted faces an exterior room such a porch and/or the Exterior Room. See “Room Types” on page 124.

- If the **Material Painter Room Mode**  is active, the selected material is applied

to the entire exterior room. If any walls defining this room also define other exterior rooms, their entire lengths are also affected.

- If the **Material Painter Component Mode**  is active, the entire length of the individual wall is painted. Other walls defining the exterior room(s) are unaffected.

Material Eyedropper

 The **Material Eyedropper** tool allows you to load the material assigned to an existing object and apply that material to other objects.

In a 3D view, select **3D> Material Painter>**

Material Eyedropper  and then move your mouse pointer over a surface in the view. The name of the material on that surface is stated on the left side of the Status Bar. Click on the surface to load its material assignment. The pointer then changes to indicate that the material is ready to be applied to another object using the **Material**

Painter  tool. Depending on the currently active **Material Painter Mode**, you can continue to apply the material to the surfaces of other objects.

Materials Tab

The specification dialogs for most objects include a Materials tab. Select an object or a group of similar objects and click the **Open Object**  edit button to open the specification dialog for that selection.

On the Materials tab, you can specify material assignments for the components that make up that object. When a new material is assigned, the appearance of the preview image on the right side of the dialog updates.

The tree list on the left side of the tab lists the components of the selected object that can be assigned materials. Some objects may only have a single component while more complex objects may have many.

Some components contain additional sub-components, which display separately in the components tree list.

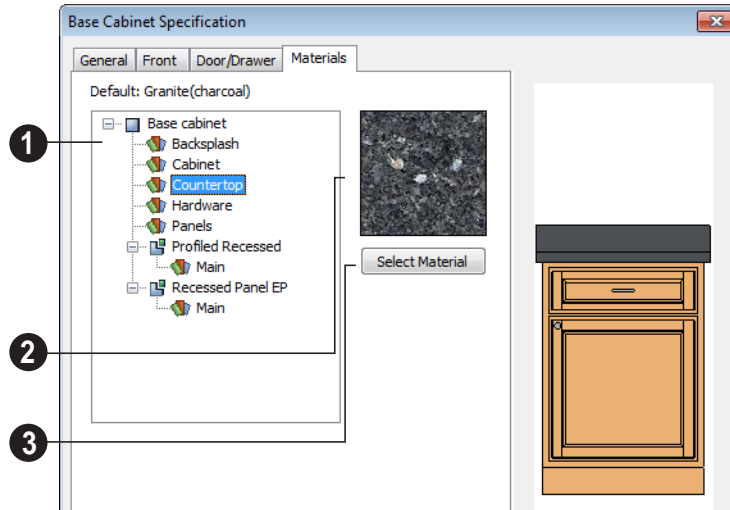

- 1 Select a component in the tree list to assign a new material to it.
- 2 The box to the right of the tree list displays a preview of the texture of the material assigned to the selected component. If “No Texture” displays in the preview window, either the material has no texture assigned or the texture file could not be found on the system.

- 3 Click **Select Material** to open the **Select Library Object** dialog. Select a material and click **OK** to assign that material to the selected component. See “Select Library Object Dialog” on page 295.

Select **OK** to close the dialog and return to the active view.

Editing Materials

Much like objects, materials in Home Designer Essentials can be edited so that they better suits your design needs. There are two approaches to material editing:

- Select a material in an unlocked library in the Library Browser, edit it, and your changes will be used when you next use the material in any plan. Changes made in this manner do not affect materials already in use in a plan.

- Apply a material to an object in a plan and then edit that applied material using the **Adjust Material Definition**  tool. Changes made in this way will affect any instances of that material in the current plan only.

Editing the material applied to an object is not the same as applying a different material to that object. See “The Material Painter” on page 301.

Library Browser

Right-click on a material in an unlocked library and select **Open** from the contextual menu to open the **Define Material** dialog for that material. See “Define Material Dialog” on page 306.

Adjust Material Definition

 The **Adjust Material Definition** tool is useful for changing plan materials directly from a 3D view.

Select **3D> Materials> Adjust Material**

Definition  and then click any surface in a 3D view to modify the material currently assigned to that surface in the **Define Material** dialog. See “Define Material Dialog” on page 306.

Changing a material definition with this tool affects all objects in the current plan that are using that material but does not affect any materials saved in the library or materials used in other plans. See “Adding Library Content” on page 290.

Creating Materials

Home Designer Essentials provides a wide variety of materials - including numerous name brand material catalogs - that are ready to download and use. If you cannot find a suitable material, you can edit an existing material or create a new one. See “Editing Materials” on page 304.

Note: Adding a material to a plan is not the same as adding it to the library. If you want a new material to be available for use in other plans, create it in the Library Browser.

In the Library Browser

Materials can be created in the Library Browser, making them available for use in any plan. See “Adding Library Content” on page 290.

In the directory pane of the Library Browser, right-click on an unlocked folder and select **New> Material** from the contextual menu. See “Using the Contextual Menus” on page 285.

In the **Define Material** dialog, you can create a new material in the selected unlocked folder. See “Define Material Dialog” on page 306.

Blending Materials

 In 3D views, you can create a new material by blending a solid color such as a paint color with a textured material. Select **3D> Material Painter> Blend Colors With Materials** to toggle this feature on or off. See “Blend Colors With Materials” on page 302.

The result is a new material that is saved in the current plan.

Materials created using the **Blend Colors With Materials**  tool are given the name of the patterned/textured material with the extension “--PAINTED:” followed by the name of the solid color material.

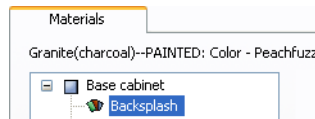

Stretch to Fit

Some special textures, often used for artwork, stretch across any surfaces that they

are applied to. Materials that behave this way are specified as **Stretch to Fit** in the **Define Material** dialog.

To display an artwork texture, first place a wall or desk frame in your plan. A selection of both are available in the library. See “Placing Library Objects” on page 293.

Next, simply apply a material specified as **Stretch to Fit** to the center portion of the frame. See “The Material Painter” on page 301.

For more information about creating and using custom materials, see “Materials Tutorial” on page 119 of the User’s Guide.

Define Material Dialog

The **Define Material** dialog allows you to adjust how materials look in 3D views and can be accessed in a number of ways:

- Use the **Adjust Material Definition**  tool. See “Adjust Material Definition” on page 305.
- Right-click on a material in an unlocked library in the Library Browser and select **Open** from the contextual menu. See “Using the Contextual Menus” on page 285.
- You can also right-click on an unlocked library and select **New> Material**.

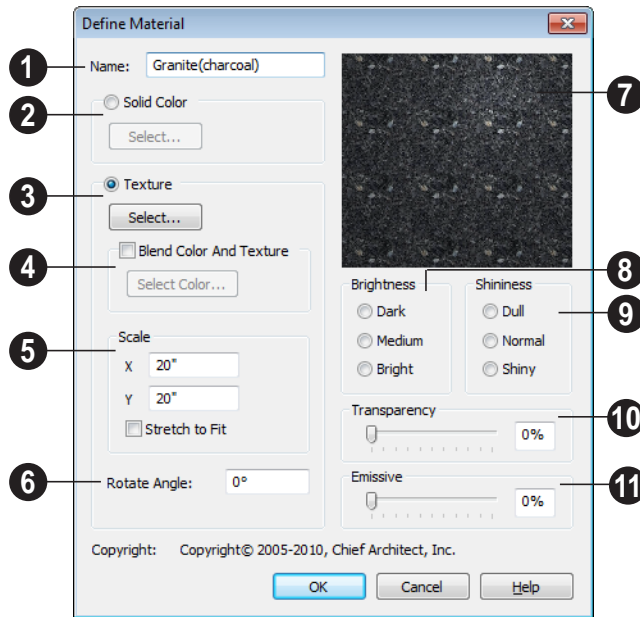

1 The **Name** of the material displays here. In this field, you can type a new name if you wish. Renaming the material does not create a new material: it redefines the existing material.

2 Click the **Solid Color** radio button to specify the material as a solid color, then click the **Select** button to open the **Color Chooser** dialog and select a new color. See “Color Chooser Dialog” on page 309.

3 Click the **Texture** radio button to specify a texture for the material instead of a solid color, then click the **Select** button to open the **Select Texture File** dialog, a standard Open File dialog, and specify an image saved on your computer to serve as the texture.

4 Check **Blend Color and Texture** to blend the selected texture with a solid color, then click the **Select Color** button to specify the color you would like to blend it with.

When a new material is created using the **Blends Color With Materials**  tool, the resulting material has this box checked. See “Blend Colors With Materials” on page 302.

5 Specify the **Scale** for the chosen texture in inches (mm). If you specify **x** and **y** values of 30”, the pattern repeats every 30 inches in both directions along a surface.

Check **Stretch to Fit** to stretch the texture image over the entirety of each surface it is applied to. This is useful when you wish to create a painting or photo material to display in a frame. See “Stretch to Fit” on page 306.

Note: Changing the scale or selecting Stretch to Fit can cause textures to appear distorted if they are mapped to a surface using a different aspect ratio than they were originally created with.

- 6 **Rotate Angle** - Specify how the texture is rotated on the surface.
- 7 A preview of the current material displays here.
- 8 **Brightness** controls how bright the material appears relative to other materials.
- 9 **Shininess** controls the sheen of the material when it is rendered with a

point or spot light source on it. Shiny materials such as metal will reflect light when viewed at the right angle.

- 10 **Transparency** controls the opacity of the material. A transparency value of 0 results in a completely opaque material, while a value of 100 creates a material that is completely invisible.
- 11 Use the **Emissive** slider bar or text field to control how bright a material appears independent of the lighting in the scene. It can be used to simulate surfaces that are glowing with their own light, such as the glass on a light fixture.

Material Defaults



Most objects in the program have defaults dialogs which allow you to set up a variety of attributes, including materials, before the objects are created. Default Settings are accessed by selecting **Edit> Default Settings**. See “Preferences & Default Settings” on page 46.

Not all objects, however, have default settings that can be accessed prior to being placed. Garage doors, for example, do not have a defaults dialog. Instead, you can specify the materials for them in the **Material Defaults** dialog. Once a garage door is created, you can change its materials.

Select **Edit> Default Settings**  from the menu, select “Materials”, and click the **Edit** button to open the **Material Defaults** dialog.

Material Defaults Dialog

The settings here are similar to those on the Materials tab found in object specification dialogs throughout the program. See “Materials Tab” on page 303.

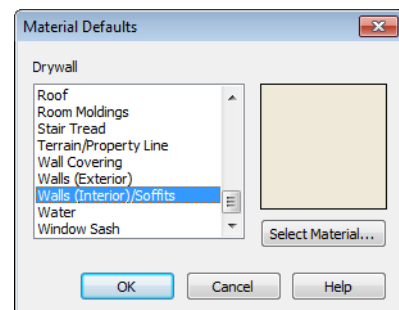

- Select a category from the scrollable list.
- Click the **Select Material** button or preview box to open the **Select Library**

Object dialog. See “Select Library Object Dialog” on page 295.

Color Chooser Dialog

The **Color Chooser** dialog is opened by clicking on the color bar that can be found in many dialogs throughout the program.

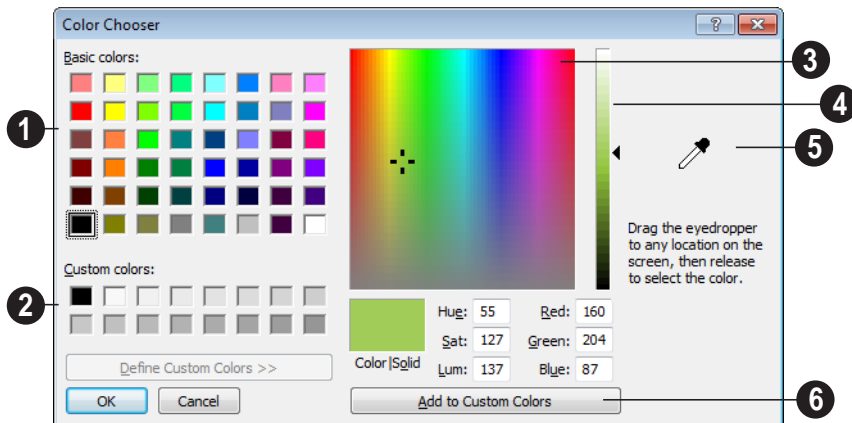

- 1 Click in any one of the **Base colors** boxes to select it as the new color.
- 2 Click in one of the **Custom colors** boxes to either select it as the new color or to specify it as the box for a new custom color to be defined.
- 3 Click anywhere in the color palette area to dynamically choose a color. The location of a selected color is identified by a black crosshairs.
- 4 Click anywhere in the vertical bar to adjust the selected color's darkness.

- 5 Drag the **Color Chooser Eyedropper** anywhere on your monitor and release the mouse button to select the color displaying at that location.

 You can select a color from any program window. Before opening the Color Chooser dialog, make sure the desired color can be seen onscreen by tiling Home Designer Essentials and the other program window.

- 6 Click **Add to Custom Colors** to add the color to selected Custom Colors box.

Zoom & View Tools

Use the Zoom tools to position the current view. To work on a specific area, you may need to zoom in so that the entire screen is filled by only a single room. At other times you may need to view the entire plan.

There is no limit to the number of plan files that can be open. The name of the file and the type of view displays at the top of each view window in its title bar.

There are a number of ways to pan across the screen, shifting the visible part of the plan slightly while still maintaining the same zoom factor.

Multiple views of one or more open files also can be arranged and managed using the View tools.



Chapter Contents

- Zoom Tools
- Undo Zoom
- Fill Window
- Panning the Display
- Swapping Views
- Window Menu Tools
- Cascade
- Tiling Views
- Arrange Icons
- Closing Views

Zoom Tools



Zoom is used to magnify any given area on the plan or 3D view. Select **Window> Zoom**, then click and drag a marquee around an area on screen. When you release the mouse, the selected area expands to fill the screen.

When the zoom is complete, whatever tool was active prior to selecting the **Zoom**  tool automatically becomes active again. If another zoom is needed, click the **Zoom**  tool again.



Zoom In - Click to zoom in towards the screen center by a factor of two.



Zoom Out - Click to zoom out from the screen center by a factor of two.



Undo Zoom - Reverse the last zoom operation. See .



Fill Window - Fits all visible items on screen. See .



Fill Window Building Only - Fits all walls and railings on the current floor on screen.



Pan Window - Move the display without changing the zoom factor. See .

Zooming With the Mouse Wheel



Use the mouse wheel to zoom in and out in plan and 3D views. Scrolling the mouse wheel one click up or down zooms in or out, centering on the location of your pointer and changing the zoom by about 10%.

Note: Depending on the configuration of your mouse, it may be necessary to hold down the Ctrl key while turning the mouse wheel. If zooming in and out are not working correctly, contact the manufacturer of your mouse and mouse driver for their assistance.

Zooming in 3D Views

Zooming in 3D views does not change the camera's location or field of view. Instead, the extents of the view are expanded or cropped.



Undo Zoom



Select **Window> Undo Zoom** to reverse the last zoom operation.



Note: Undo and Redo do not affect zoom.



Zoom  and **Undo Zoom**  are also available through the contextual menu. See "Contextual Menus" on page 22.

Fill Window

 In floor plan view or an Elevation view, select **Window> Fill Window** or press the **F6** key to view nearly everything on screen that is visible, including the Reference Display. CAD Points are the only objects that are not included when Fill Window is used.



If you are zoomed in so that only a portion of the drawing displays on screen, selecting **Fill Window**  zooms out so that the entire view fits on the screen. If you are zoomed out so that the entire drawing is smaller than the screen, selecting **Fill Window**  zooms in until the drawing fills the screen.

When the drawing sheet is shown, **Fill Window**  zooms to the sheet borders.

Fill Window Building Only

 **Window> Fill Window Building Only** is similar to **Fill Window**, but zooms in or out so that all walls and railings in the view fill the current window. Other objects are ignored.

In 3D Views

In 3D views, **Fill Window**  and **Fill Window Building Only**  adjust the camera's Field of View is adjusted so that all surfaces in the 3D view are included.

Panning the Display

There are four ways to pan the display without changing the zoom factor.

Using the Scroll Bars

One method is to use the scroll bars on the right and bottom edges of the window.

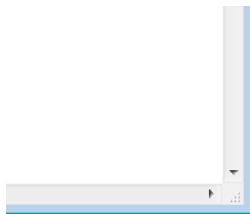

- Drag the square button in the bar itself in order to pan a larger distance.

- Click the end arrow keys on the scroll bars to shift the display in 12" increments.
- The 12" increment is defined in the **Plan Defaults** dialog under **Inches Scrolled by Arrow Key**. See “General Plan Defaults Dialog” on page 48.

Using the Arrow Keys

In floor plan view, the arrow keys on the keyboard work exactly like clicking the arrow buttons on the scroll bar. They shift the display according to the number of inches defined in the **Plan Defaults** dialog.

Using the Mouse



If you have a wheel mouse, you can pan the display by pressing the middle mouse button, or wheel, and moving the mouse in the direction you would like to pan. When the middle mouse button is held down, the pointer changes to a hand  icon.

Mouse drivers sometimes have other functions assigned to the wheel and buttons. These override the Home Designer Essentials setting.

Using the Pan Window Tool





The **Pan Window** tool works much like the mouse wheel method.

Select **Window > Pan Window** . The pointer changes to a hand  icon. Click and drag in floor plan view to pan the window. The command is invoked once and the program reverts to the previously active tool when you release the mouse button.

Swapping Views

There are several ways to switch between open view windows.

- Select **Window > Next Window**  or **Window > Previous Window**  to cycle through all open views in the order you prefer.
- Press the Ctrl + Tab (Next Window) or Ctrl + Shift + Tab (Previous Window) keys to cycle through all open views.
- A list of all the views currently open is located at the bottom of the Window menu. Each view is identified by its name and what type of view it is. Select one to go directly to that view.

Window Menu Tools

Select **Window** from the menu to access the Window Menu tools, which help you display multiple view windows of your model at the same time.



Select **Window > Cascade** to cascade all open views. See “Cascade” on page 314.



Select **Window > Tile Horizontally** or **Tile Vertically** to tile all open views. See “Tiling Views” on page 316.



Select **Window > Arrange Icons** to arrange all open views that are currently minimized. See “Arrange Icons” on page 317.



Select **Window > Next Window** to switch to the next open view. See “Swapping Views” on page 313.



Select **Window > Previous Window** to switch to the previous open view. See “Swapping Views” on page 313.

Open View Windows

There is no limit to the number of plan files that can be open. The name of the file and the type of view displays at the top of each view window in its title bar.

There is no limit to the number of 3D view windows that you can have open at a given time; bear in mind, though, that each window demands use of your computer's resources and that you may see poor performance if too many views are open. See "3D Views" on page 318.

A list of all view windows currently open displays at the bottom of the Window menu. Each view is identified by its name and what type of view it is. A checkmark is beside the view that is currently active. Select one to go directly to that view.

The names of up to eight views can display here. If more than eight view windows are open, **More Windows** is the last item in the menu. Select this option to open the **Select Window** dialog.

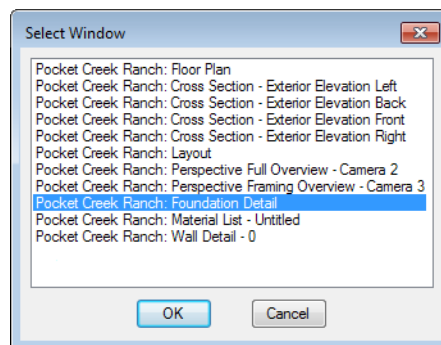

Select the name of a view from the list and click **OK** to make it the active view.

Cascade



Select **Window > Cascade** to cascade all open views. Cascade is a Windows function which allows you to organize open

windows in a cascading pattern. Click on any visible edge to activate that window.

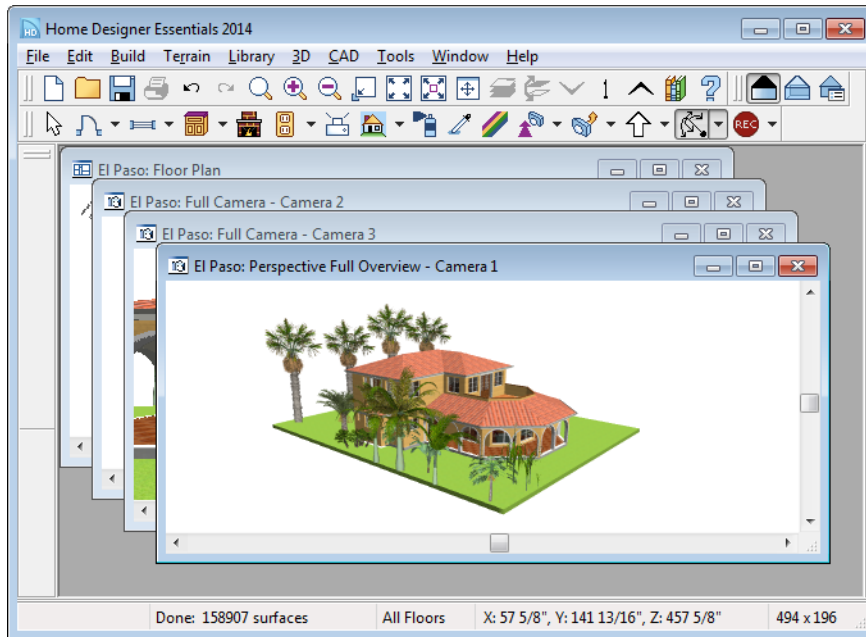

Tiling Views

 The window tiling options allow you to display multiple views side by side in the Home Designer Essentials window.

Select **Window> Tile Horizontally**  to display both views in a horizontal orientation.

Select **Window> Tile Vertically**  or press Shift + F6 on the keyboard to display both views in a vertical orientation.

To activate a view, click on its title bar or anywhere in the view window. Note that any changes you make are reflected in other views as well.

To end window tiling, click the **Maximize**  button in the upper right corner of any open view.

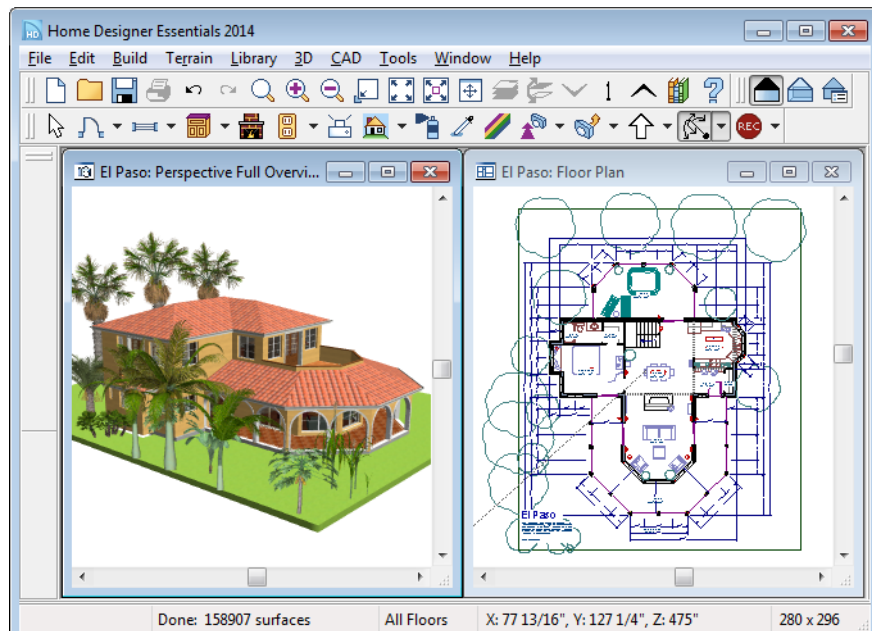

Tiling allows you to see the results of changes in floor plan view in 3D or vice

versa, and can also be useful for copying objects from one plan to another.

Arrange Icons



Arrange Icons is a Windows function used when several active windows have been minimized. Select **Window> Arrange Icons** to align the minimized title

bars in a row at the bottom of the working desktop. You can then click the minimized title bars to reactivate them or use them for swapping and closing views.

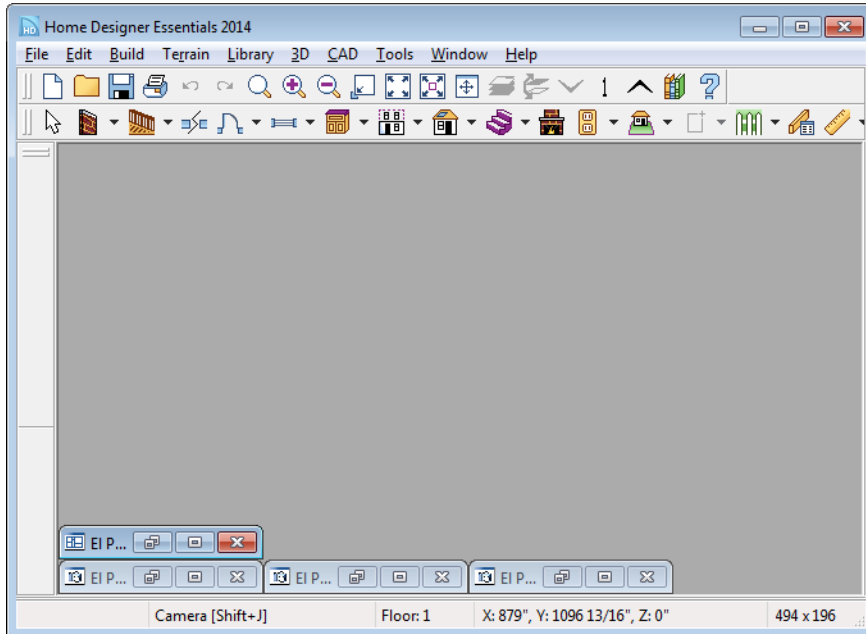

Closing Views

Select **File> Close** or click the **✕** at the top right corner of a window to close it. If the

view is still needed, swap to a different view without closing the current views.

3D Views

Little preparation is needed to create a 3D view of a model: simply click a button to create an overview or click and drag to create a cameraelevation view.

To improve the quality of the rendering and create a custom look, you can adjust lighting and edit the materials used in the plan. You can create Final views that are even more realistic. See “3D Rendering” on page 336.

Many objects can be placed and edited in 3D views, and any camera view or overview can be saved or even used to record a walkthrough. See “Pictures, Images, & Walkthroughs” on page 370.

Chapter Contents

- OpenGL and Hardware
- 3D Backdrop Dialog
- 3D View Tools
- Creating Camera Views
- Creating Overviews
- Elevation Views
- Displaying 3D Views
- Repositioning Cameras
- Editing 3D Views
- Cross Section Slider
- Working in 3D
- Printing 3D Views
- Camera Specification Dialog

OpenGL and Hardware

Home Designer Essentials features a built in, easy to use rendering engine that makes use of OpenGL rendering technology, which has good hardware support on most video cards.

To take full advantage of the rendering capabilities of Home Designer Essentials, a graphics card that supports OpenGL

hardware acceleration and has at least 256 MB of dedicated video memory is highly recommended. For complex models, an accelerated card generates quality renderings in seconds that might otherwise take minutes or even hours with a non-accelerated card or chipset.

3D Backdrop Dialog



Select **3D > 3D Backdrop** from the menu to open the **3D Backdrop** dialog. This dialog allows you to specify a

solid color or picture file of your choice to use as a background for 3D views. See “3D Backdrops” on page 324.

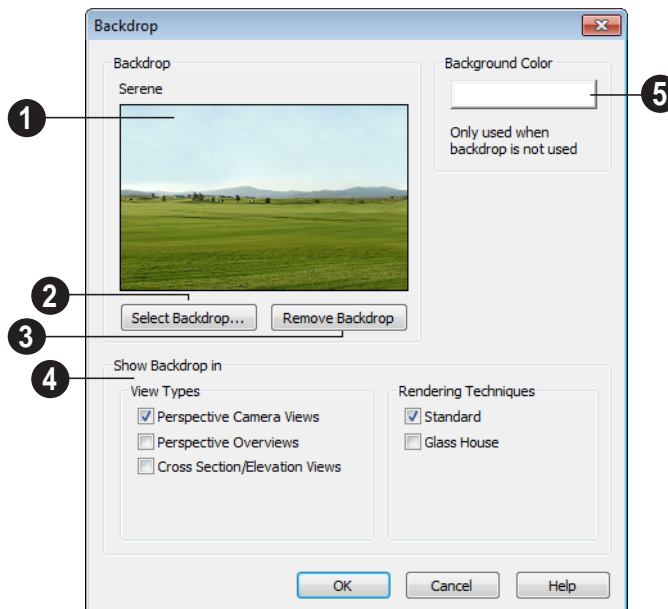

1 A preview of the selected backdrop is shown here, and its name displays for reference. See “3D Backdrops” on page 324.

2 Click **Select Backdrop** to open the **Select Library Object** dialog. Browse the **Backdrops** library, select a backdrop, and click OK.

- 3 Click **Remove Backdrop** to change the backdrop to a solid color. The color used is defined in the **Background Color** section of this dialog.
- 4 **Show Backdrop in** - Specify where the selected backdrop image displays.
 - Specify which **View Types** you would like to use the selected backdrop in. By default, only Perspective Camera Views use a backdrop.
- 5 Click the color bar to select the **Background Color** that displays when a backdrop image is not being used. See “Color Chooser Dialog” on page 309.

3D View Tools

Select **3D> Create Camera View** to display the Camera View Tools.

Camera Views



The **Full Camera** tool creates multi-floor views of the 3D model. It can be used to create interior and exterior perspectives, and is good for displaying cathedral ceilings, roofs, lofts, stairwell openings, and other variation in floor and ceiling levels.



The **Glass House Camera** tool creates full camera view of the 3D model using the Glass House Rendering Technique. See “Glass House View” on page 339.

Overviews



The **Full Overview** tool creates views of the entire model including all floors, ceilings, and the roof.



The **Doll House View** tool creates views of the current floor without a roof or ceiling.



The **Framing Overview** tool creates views of the framing in the model. See “Framing Overview” on page 322.

Elevation Views



The **Wall Elevation** tool creates views similar to the traditional, orthographic views often used in drafting. See “Elevation Views” on page 322.

- When an interior view is created, an elevation of a wall on a single floor and in a single room is shown.
- When an exterior view is created, the entire model is shown.

Creating Camera Views

To create a camera view

1. In floor plan view, select the desired camera tool. The mouse pointer displays the camera  icon.
2. Click and drag a line to define the view direction.
 - Where your line begins is the camera's position.
 - The line that you drag defines the direction the camera is pointed.
 - The end of the line is the focal point of the view, the point the camera rotates around.
 - By default, the field of view is 45°, which is similar to what the human eye sees or a 50mm camera lens.

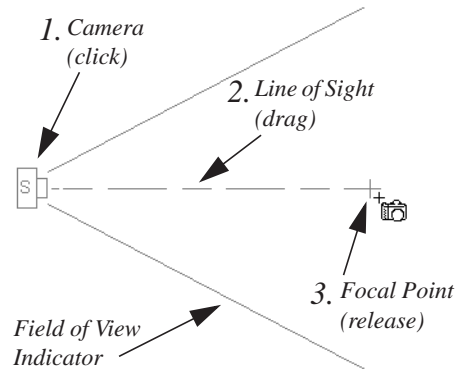

3. When you release the mouse button, a view generates in a new window.
4. Return to the floor plan view. A camera symbol now displays in floor plan view. See “Swapping Views” on page 313.

Creating Overviews

Overviews generate as soon as you select the tool and are always created at the same angle. The focal point is always located at the center of the model; however, the position of the camera will vary depending on the size of the 3D model. The larger or more spread out the model, the further away the camera will be from the focal point so that the entire model can be seen in the view.

Once generated, an overview window's title bar indicates its view type and a camera symbol representing the overview displays in floor plan view. The overview 'camera' can be edited much like regular camera views can. See “Editing 3D Views” on page 328.

Full Overview

-  Select **3D > Create Camera View > Full Overview** to generate an exterior view of the entire model.





Doll House View



Select **3D> Create Camera View> Doll House View** to create a view of the current floor with the ceiling removed and all floors beneath it visible.

Doll House Views are an effective tool for illustrating traffic flow and the relationships between spaces.



To see a different floor, select **Tools> Reference Floors> Up One Floor**  or **Down One Floor** . You can also return to

floor plan view and make another floor current before generating the Doll House View.

Framing Overview



Select **3D> Create Camera View> Framing Overview** to create a view of the entire model, displaying only framing and the foundation.

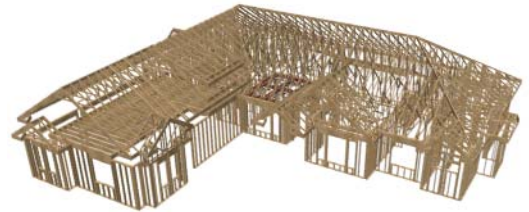



Framing overviews include all floor, wall, and roof framing as well as foundations.

Elevation Views



The **Elevation** tool produces views in which all lines and dimensions are their true lengths, regardless of their distance from the camera.

To create an Elevation view

1. Select the **Elevation**  tool. The pointer changes to a  with crosshairs marking the position of the pointer.
 - Click in the building's interior to create an elevation of a wall on a single floor and in a single room.
 - Click outside of the building to create a view of the entire model.

2. Click and drag a line in floor plan view.
 - A Camera symbol displays where you click.

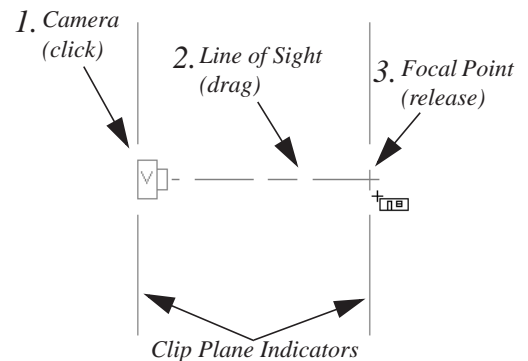

3. Drag in the direction of the Line of Sight to draw a camera arrow.
 - Always drag the camera arrow perpendicular to the wall to be viewed.
4. When you release the mouse button, the view generates in a new window.

If the Line of Sight does not cut through a 3D object, such as a window shown in elevation, the object retains its 3D definition and can be selected, moved, stretched, or otherwise modified in the view. The 3D model is updated in all views.

Displaying 3D Views

A variety of tools and settings allow you to control the appearance of your 3D views. There are also numerous ways to adjust the position, focal point and field of view of a 3D view. See “Editing 3D Views” on page 328.

The name of the current plan file and the type of view displays at the top of each view window in its title bar.

There is no limit to the number of 3D view windows that you can have open at a given time; bear in mind, though, that each window demands use of your computer’s resources and that you may see poor performance if too many views are open. See “Open View Windows” on page 314.

Display Options



Which objects display in a 3D view is controlled in the **Display Options** dialog. See “Display Options Dialog” on page 60.

Different view types use different layer sets when they are created. See “Layer Sets” on page 59.

In Floor Plan View

3D cameras are represented in floor plan view by symbols that indicate the camera’s position, field of view and focal point.

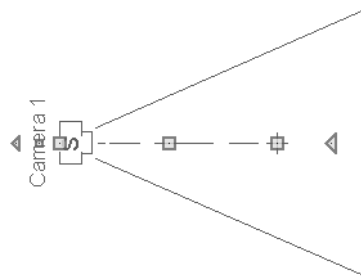

Active cameras can have labels indicating the camera number. Camera labels are located on the “Cameras, Labels” layer. They are numbered sequentially in each plan in the order they were created.



Camera symbols are an on-screen reference: they do not print unless **Print Image** is used.

In Rendered Views

There are a number of factors that contribute to the appearance of rendered 3D views:

- Select **3D> Toggle Textures**  in a 3D view to turn off the display of material

textures. See “About Materials” on page 300. Not available in Glass House Views.

- Select **3D> Lighting> Adjust Sunlight**  to open the **Default Sun Light Specification** dialog. See “Default Sun Light Specification Dialog” on page 339.
- Select **3D> Lighting> Toggle Sunlight** to turn on and off the light source that represents the sun. This feature can be used to simulate day vs. night exterior views. User defined exterior lights are turned off in day views and turned on in night views. See “Default Sun Light” on page 338.
- Select **3D> Final View**  or **Final View with Shadows**  to regenerate the 3D view with improved quality and/or shadows. See “Previews vs Final Views” on page 337

3D Backdrops

A backdrop image is like a large billboard image that displays behind the model in 3D views. Backdrop images often show an outdoor scene to add realism and a sense of perspective to 3D views. You can select a backdrop image for a plan from the library in either of two ways:

- In any view, select **3D> 3D Backdrop**  to open the **3D Backdrop** dialog. See “3D Backdrop Dialog” on page 319.
- In a 3D view, open the Library Browser. Browse to and select a Backdrop image, then move your cursor into the view window. Click anywhere in the view to apply the selected backdrop.

Regardless of how it is selected, only one backdrop can be used in a plan at any given time.

You can specify which view types and Rendering Techniques use the selected backdrop in the **3D Backdrop** dialog.

Delete 3D Surface

 The individual surface of an object can be temporarily removed from any 3D view by selecting **3D> Delete Surface** and then clicking on a surface. When the pointer is over a surface, that surface will become highlighted.

Surfaces removed in one view are removed in all 3D views, but are not permanently removed from the model. Continue clicking surfaces to remove them, then select another tool when you are finished.

Surfaces in 3D views are composed of multiple triangles. Hold the Alt key while clicking to delete one triangular face at a time rather than all triangles forming a surface.

Select **3D> Delete Surface** or click the toolbar button to restore the most recently deleted surface. All surfaces can be restored by selecting **Build> Floor> Rebuild Walls/Floors/Ceilings** or by exiting the 3D view and reopening it.

Rebuild 3D

 Select **3D> Rebuild 3D** to regenerate all 3D data associated with the current plan. All open views will remain open.

Repositioning Cameras

Once a 3D view is created, there are many ways to manipulate the camera location and the direction of its line of site using the mouse, the keyboard, and the menus.

When the keyboard or menu commands are used to move or rotate a camera, the adjustments occur in regular increments. The size of these increments is specified in the **Camera Specification** dialog:

- The **Incremental Move Distance** controls Panning movement and forward and backward Dolly movement.

- The **Incremental Rotate Angle** controls Orbit movement, Tilt movement, and side to side Dolly movement.

See “Camera Specification Dialog” on page 333.





Each time you move the camera, the view is updated. If you are using either the toolbar or keyboard to move the camera, you can hold down the Shift key, suppressing the redraw of the view until the Shift key is released and allowing you to move multiple increments more quickly.

Move Camera with Mouse



An active camera’s position can be edited using the mouse. Select **3D> Move Camera With Mouse** to access the

Move Camera with Mouse modes. These tools are not available in Elevation views.

	Hotkey	Description
	Alt + O	Mouse-Orbit Camera lets you move the mouse to rotate the camera around its focal point. The camera’s position and direction both change. To continuously rotate the camera around its focal point, click in the 3D view, drag the mouse, and release the mouse button to “throw” the view. Click again in the view to stop it from rotating.
	Alt + P	Mouse-Pan Camera lets you move the mouse to move the camera up, down, left and right. The camera’s position changes, but its direction does not.
	Alt + D	Mouse-Dolly Camera lets you move the mouse up and down to move the camera forward and backward. Move the mouse left or right to rotate the camera side to side.
	Alt + T	Mouse-Tilt Camera lets you move the mouse to tilt the camera in any direction while staying in the same location.

	Hotkey	Description
		3D Center Camera on Point lets you focus the camera at a particular point in the scene. This also sets the camera center so that future use of Mouse-Orbit Camera rotates around that point. To use the 3D Center tool, activate the tool and then click on any object in the scene.

Move Camera with Arrow Keys

An active camera's position can be changed using the arrow keys on your keyboard.

Select **3D > Move Camera with Arrow Keys** to access Move Camera with Arrow Key modes. These tools are not available in Elevation views.



These modes use the **Incremental Move Distance** and **Incremental Rotate Angle** set in the active 3D view's **Camera Specification** dialog.





- **Arrow-Orbit Camera** lets you use the arrow keys to rotate the camera around the current focal point. The camera's position and direction both change.
- **Arrow-Pan Camera** lets you move the camera up, down, right, and left using the arrow keys. The camera's position changes, but its direction does not.
- **Arrow-Dolly Camera** lets you move the camera forward and back using the up and down arrow keys, and rotate side to side using the left and right arrow keys.
- **Arrow-Tilt Camera** lets you use the arrow keys to tilt the camera up, down, or side to side to change the focal point. The camera's direction changes, but its position does not.

Move Camera Tools

 Select **3D > Move Camera** in a 3D view to access these tools. These tools change the active camera's position, but not its direction and are not available in Elevation views.

These tools use the **Incremental Move Distance** set in the active 3D view's **Camera Specification** dialog.

	Hotkey	Description
	F	Move Camera Forward moves the camera and its focal point forward.
	B	Move Camera Back moves the camera and the focal point back.





	Hotkey	Description
	L	Move Camera Left moves the camera and the focal point to the left in a line perpendicular to the line of sight.
	R	Move Camera Right moves the camera and the focal point to the right in a line perpendicular to the line of sight.
	U	Move Camera Up moves the camera and the focal point up.
	D	Move Camera Down moves the camera and the focal point down.

Orbit Camera Tools

 Select **3D> Orbit Camera** in a 3D view to access these tools. Orbiting the camera rotates it about the focal point using the **Incremental Rotate Angle** set in

the active view's **Camera Specification** dialog.

These tools are not available in Elevation views.

	Hotkey	Description
	I	Move Camera In moves the camera closer to the focal point along the line of sight. The camera cannot move past the focal point using this tool.
	O	Move Camera Out moves the camera away from the focal point along the line of sight.
		Orbit Camera Upward rotates the camera up about the focal point. The camera cannot rotate past a vertical line looking straight down on the focal point.
		Orbit Camera Downward rotates the camera down about the focal point. The camera cannot rotate past a vertical line looking straight up at the focal point.
		Orbit Camera Left rotates the camera to the left about the focal point.





	Hotkey	Description
		Orbit Camera Right rotates the camera to the right about the focal point.

Tilt Camera Tools

 Select **3D> Tilt Camera** to access these tools. Tilting keeps the camera in one place and pivots the camera about its vertical or horizontal axis. This movement uses the **Incremental Rotate Angle** set in the active view's **Camera Specification**

dialog and is similar to tilting your head up and down or turning it side-to-side.

These tools are not available in Elevation views.

	Hotkey	Description
		Tilt Camera Upward tilts the camera up while keeping it in the same location. The camera cannot tilt beyond the vertical position.
		Tilt Camera Downward tilts the camera down while keeping it in the same location. The camera cannot tilt beyond the vertical position.
		Turn Camera Left turns the camera to the left while staying in the same location.
		Turn Camera Right turns the camera to the right while staying in the same location.

Editing 3D Views

In addition to its position and direction, there are other ways to modify a 3D view.

adjustments to the camera's position, appearance, and other attributes. See "Camera Specification Dialog" on page 333.

In the Specification Dialog

 You can make adjustments to a camera view or overview in the **Camera Specification** dialog. This dialog is particularly helpful for making fine

 Tile a 3D view and the floor plan view and use the camera movement tools to see how they affect the camera. See "Tiling Views" on page 316.

Using the Edit Handles

Return to floor plan view without closing the 3D view. See “Swapping Views” on page 313.

Using the **Select Objects**  tool, select the camera object. When a camera symbol is selected it displays four edit handles.

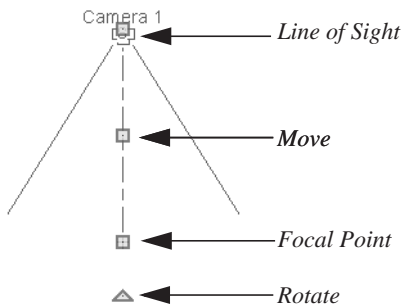

- Drag the **Line of Sight** handle to change the camera angle without moving the focal point.
- Drag the **Move** handle to relocate the camera while maintaining its relative angle.
- Drag the **Focal Point** handle to reposition the focal point and change the line of sight without moving the camera.
- Drag the **Rotate** handle to rotate the camera's line of sight about its center.

The 3D view corresponding to the camera symbol reflects changes made to the symbol in floor plan view.

Multiple camera symbols can be selected; however, their editing options are limited to being moved, rotated, and deleted.

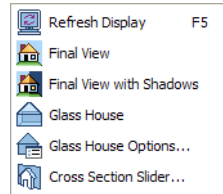

Using the Contextual Menu

In a 3D view, right-click in an empty space in which the backdrop or background color displays to access the contextual menu. See “Contextual Menus” on page 22.



These options are a selection of tools and toggles specific to 3D views.

Up One Floor/Down One Floor



You can move a camera to a different floor. While the camera view is active, select **Tools > Reference Floors > Up One Floor**  or **Down One Floor** .

The position and movement of a camera is affected by its location within the model. When the camera is outside a building, its height is relative to the terrain and follows the terrain as it is moved. When inside a building, the camera height is relative to the floor of the room it is drawn in.

If the camera is on an upper floor and you move the camera outside of the building, the camera remains at the same height relative to the floor it was created on.

Zooming

 The **Zoom Tools** are available in all 3D views. See “Zoom Tools” on page 311.

Selecting **Window > Zoom In** , **Zoom Out**  or **Fill Window**  does not change the camera's location or field of view. Instead, the extents of the view are expanded or cropped.

Field of View

The **Field of View** refers to a camera's field of vision. A wider field of view makes the focal point appear further away, as more of the image is included in the same view window.

In floor plan view, the angled lines of a camera symbol indicate its field of view.

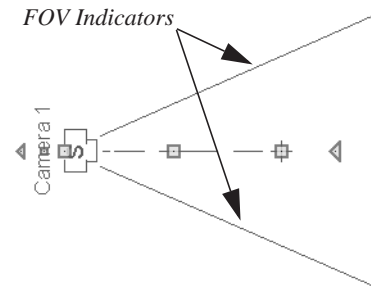

A camera's field of view can be adjusted in the **Camera Specification** dialog. See "Camera Specification Dialog" on page 333.

The field of view can also be adjusted while in a camera view using the keyboard:

- **W** - Increase camera Field of View.
- **N** - Decrease camera Field of View.

Cross Section Slider



Select **3D > Cross Section Slider** when a camera view or overview is

active to open the **Cross Section Slider** dialog.

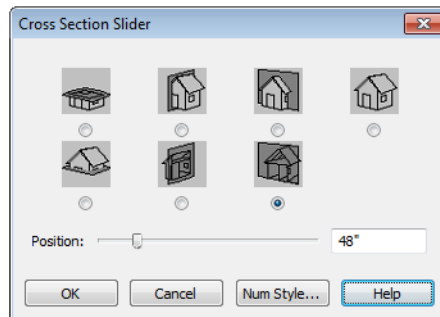

To use the Cross Section Slider

1. Click on the radio button beneath one of the cross section angles to select it.
 - The option at top right turns off the cutting plane, so no cross section is made.
2. Move the **Position** slider to adjust the position of the cutting plane.
3. You can position the cutting plane with accuracy using the text field to the right of the slider.
 - This value is measured from the edge of the model that is cut first by the selected cross section angle.
4. Click **OK** to close the dialog.

Working in 3D

A variety of tools are available in 3D views that allow you to edit your 3D model.

Creating Objects in 3D Views

You can place windows, doors, and most library objects directly into 3D views. To do this, select the appropriate tool and click in the 3D view. You can then edit the object's size and placement.

When created in 3D, most objects must be placed against a wall, on a floor platform, or within the Terrain Perimeter.

You can also click and drag to draw some objects such as terrain features and road, in camera views and overviews views.

Selecting and Editing Objects in 3D Views

Most objects can be selected and edited in 3D views. Select **Edit> Select Objects**  and click on the surface of an object to select it. Once selected, objects can be edited using their edit handles, buttons on the edit toolbar, and the object's specification dialog. See "Editing Objects" on page 70.

When you select an object, edit handles and a handle surface display. The handle surface is a rectangle around the perimeter of the object that indicates the overall height and width of the selected surface. The edit handles that display depend on the type of object selected. Walls, for example, display two resize edit handles when selected while a slab displays ten handles, allowing you to move, resize and reshape it.

Note: If the wall height of the Exterior Room is adjusted in a 3D view, the default Floor or Ceiling Height of the entire floor is changed. See "Floor and Room Defaults" on page 121.

All moving or resizing is in the plane of the handle surface. You cannot move an object directly towards or away from the camera, for example, because that surface plane cannot be seen in the view.

By default, object movement is restricted to one inch or 10 mm increments. See "Grid Snaps" on page 64.

Unrestricted positioning can also be enabled by holding down the Ctrl key while moving or resizing an object. See "Unrestricted Movement" on page 88.

When **Fixtures and Furniture May Be Resized** is unchecked in the **Plan Defaults** dialog, only a single handle displays for furniture and stand-alone fixtures and appliances. In this case, the object can only be moved. See “General Plan Defaults Dialog” on page 48.

Temporary dimension lines display when many objects are selected to help you resize the object and determine its height.

Because Elevation views are orthogonal and display objects at their actual dimensions, they are sometimes more suitable for editing objects than camera views or overviews. See “Elevation Views” on page 322.

When several 3D views are open, changes made in the plan automatically rebuild the model in all views. Because of this, it is typically faster to make changes to your plan with as few windows open as possible.

Editing Materials in 3D Views



Select **3D> Materials> Adjust Material Definition**, then click on a surface in the 3D view to open the **Define Material** dialog for that material. See “Adjust Material Definition” on page 305.



Select **3D> Material Painter** to apply materials to surfaces in the view using the Material Painter Tools. See “The Material Painter” on page 301.



Select **3D> Material Painter> Material Eyedropper** to apply the material on a surface in the view to other surfaces in the view. See “Material Eyedropper” on page 303.

Rebuild 3D



As changes are made to your plan, a 3D view automatically updates to reflect any changes visible in the view. If you find that a view is not updating as expected, select **3D> Rebuild 3D** to rebuild the entire 3D model.

Printing 3D Views

3D camera views and overviews can be exported and saved as image files, as well as printed.

Exporting 3D Views



All 3D views can be exported and saved as .bmp, .jpg, .png, or .tif files. Select **File> Export> Picture** to save the current screen image as an image file. See “To export a picture” on page 375.

Once saved, a picture can be opened and converted into many other formats using a graphics program.

When a picture is exported, it is assigned the same size as it displays on screen. You can change the size of the view window to create a smaller or bigger picture.

Printing 3D Views



Since 3D views are created using pixels instead of lines, **File> Print>**

Print Image must be used when printing. **Print Image** is a special Home Designer Essentials function that prints the screen in picture format. The entire view prints, including images such as plants and textures.

The quality of your print image is affected by your current window size and screen resolution. To maximize the quality of your printed image, generate it in full screen size and use the maximum screen resolution.

Camera Specification Dialog



The **Camera Specification** dialog can be accessed in floor plan view by selecting a camera symbol and clicking the **Open Object** edit button. See “In Floor Plan View” on page 323.

This dialog can also be accessed while a camera view or overview is active by selecting **3D> Edit Active Camera** .

The selected view’s specific type is indicated in the dialog’s title bar: the specification dialog for a **Full Camera** , for example, is named **Full Camera Specification**.

Note: Elevation views do not have a specification dialog. See “Elevation Views” on page 320.

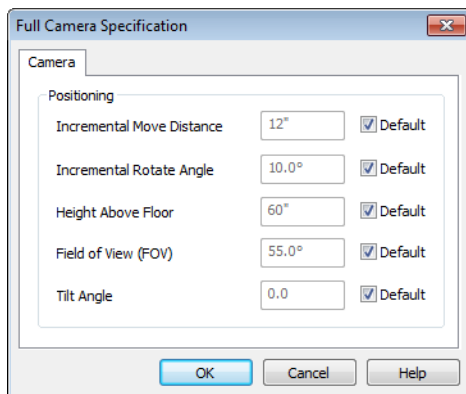

To change a setting, first uncheck **Default**, then type a new value in the text field.

- The **Incremental Move Distance** controls how far the camera moves each time you Pan in any direction or Dolly forwards or backward. For interior views a small number is good, but for exterior you may want a larger increment.
- The **Incremental Rotate Angle** defines how many degrees the camera rotates each time you Tilt, Orbit, or Dolly side to side. A setting of 90° would make one full rotation in four moves.
- The **Height Above Floor** defines the height that the camera is above the floor level for the current floor.
- The **Field of View** defines the camera’s field of vision in angular degrees. See “Field of View” on page 330.



You can increase a camera’s Field of View when the view is active by pressing the W key, or decrease the Field of View by pressing the N key.

- The **Tilt Angle** determines the angle the camera is tilted. The camera maintains its focal point and position in floor plan view, but if the camera is tilted, the focal point is above or below the current camera height.

3D Rendering

There are a variety of tools available to create 3D views of a model: simply click a button to create an overview, or click and drag to create a camera or elevation view. See “3D Views” on page 318.

To improve the quality of the rendering and create a custom look, you can adjust lighting, edit the materials used in the plan, choose from several rendering techniques and fine-tune 3D view quality settings. From most 3D

views, you can create Final views of even higher quality.

Chapter Contents

- Rendering Tips
- Lighting
- Displaying Lights
- Default Sun Light Specification Dialog
- Glass House View
- Speeding up 3D View Generation

Rendering Tips

There are a variety of factors which affect the appearance and quality of rendered 3D views. You can use these tools and settings to achieve renderings that meet your needs.

Lighting

Lighting is extremely important in most 3D renderings. Lighting controls the visibility of objects in a view, affects the appearance of surfaces, and influences the appearances of colors and textures on those surfaces. Even

small changes to light intensity, direction and color can have a large impact on image quality. See “Lighting” on page 337.

Material Textures

Textures are graphic files that represent contoured surfaces of objects such as carpet, bricks, tile, and wood in 3D views. Textures are assigned to materials which in turn are assigned to objects. See “Textures” on page 301.

The display of materials in 3D views is controlled by settings in the **Define Material** dialog. See “Define Material Dialog” on page 306.

Brightness, shininess and transparency control how light sources affect the display of surfaces in 3D views. See “Lighting” on page 337.

If no texture is selected for a material or if the display of textures is turned off, affected surfaces are a solid color instead.

Images

Images are very important for the appearance of 3D views. Images are picture files that represent individual objects such as trees, flowers, cars, and people. See “Placing Images” on page 371.

Backdrops

Backdrops are images that display in the background of 3D views. Only one backdrop can be used at a time. If a backdrop is not applied, Home Designer Essentials applies a background color.



Backdrops and background colors are selected in the **3D Backdrop** dialog. See “3D Backdrop Dialog” on page 319.

You can also add a backdrop directly into a 3D view from the Library Browser. To do this, select a backdrop in the the Library Browser and move your pointer into the view window. The pointer will display the Backdrop  icon. Click once in the view to apply the selected backdrop to this and all other 3D views using backdrops in the current plan.

Previews vs Final Views

When a rendered 3D view is first created, it uses quality settings that allow the view to generate quickly but with reasonable quality.

Final Views produce much higher quality images that are more suitable for printing or saving as graphics files. Final Views often take significantly longer to generate than Previews, so the 3D view reverts back to the Preview settings as soon as anything is changed within the view.

When you have finished making adjustments in the 3D view, select **3D> Final View**  or **Final View with Shadows** .

Lighting

In 3D views, lighting is calculated on a room-by-room basis; only the light sources in the room containing the camera are used.

When the camera is outside a building, the program normally uses sunlight for lighting calculations and turns off all other light sources. You can turn the sunlight off and use

all the other exterior lights to simulate night time views.

The maximum number of light sources that can be turned on in a view at the same time is determined by your video card. If your video card’s maximum number of lights is eight,

the program only uses the eight light sources closest to the camera's position.

There are three ways to create light sources for 3D views:

- Default Lights
- Light Fixtures
- Sunlight

Default Lights

If you create an interior 3D view of a room and no lights have been placed there, the program creates a Default Light source within that room. The Default interior light acts like a central point light source.

The Default Light cannot be adjusted in any way. If you want to control the light in an interior 3D view, you must add a light to the room that you are rendering by placing a lighting fixture.

Light Fixtures

An electric symbol that represents a **Light Fixture** has a light source associated with it. When a light is placed in a room, it will be used as a light source in 3D views instead of the Default Light. In large rooms, more than one light fixture may be needed for sufficient light.

Default Sun Light

If you create an exterior 3D view, the program creates a **Default Sun** light source.

The Default Sun can be opened for specification in a 3D view by selecting **3D>**

Lighting> Adjust Sunlight . See “Default Sun Light Specification Dialog” on page 339.

Select **3D> Lighting> Toggle Sunlight**  turn the Default Sun on or off to simulate either daytime or nighttime exterior lighting.

Displaying Lights



The display of light fixtures in floor plan and 3D views is controlled in the **Display Options** dialog. See “Display Options Dialog” on page 60.



In addition, they can serve as sources of light in rendered 3D views. They can be turned on and off, as well.

Light fixtures are placed on the “Electrical” layer. See “Displaying Objects” on page 59.

In floor plan view, light fixtures can display labels when the “Electrical, Labels” layer is turned on.

To turn a light on or off

There are several ways to turn a light fixture on or off:

- Select one or more fixtures and click the **Turn Light(s) Off in 3D**  or **Turn Light(s) On in 3D**  edit button.

Default Sun Light Specification Dialog

The **Default Sun Light Specification** dialog allows you to control the intensity, direction and color of the Default Sun light source.

While in a 3D view, select **3D> Lighting>**

Adjust Sunlight . See “Default Sun Light” on page 338.

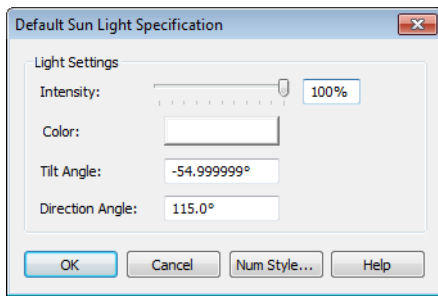

- Use the **Intensity** slider bar or text field to control how bright the default sun light appears in 3D views.

An intensity of 0% is the same as turning

the sun light off. An intensity of 100% is the maximum brightness allowed.

- Click the **Color** bar to define the color of the light being modeled. Colored sun light may be used to achieve special lighting effects, but may alter the appearance of your material colors and textures.
- Specify the **Tilt Angle**, which is the angle of the sun light with respect to the horizon. A value of 90° means that the light points straight up, while a value of -90° means that the light points straight down. 0° is parallel to the horizon.
- Specify the **Direction Angle**, which is the direction that the sun light points toward. Zero degrees is measured horizontally on screen, pointing to the right. Positive values rotate in a counter-clockwise direction from there, while negative values rotate clockwise.

The Default Sun light color is pure white, which has the least effect on the material colors and textures.

Glass House View



Glass House View can be used to display the 3D model using semi-transparent surfaces. Different shades of blue are used to represent surfaces and surface edge lines. Lighting is not modeled, and materials are not represented, so neither pattern lines nor textures are used.

Glass House View is an excellent way to illustrate the spatial relationships between different areas in the plan.

You can display a current camera view or overview as a Glass House View by selecting **3D> Rendering Techniques> Glass**

House .

To switch back, select **3D> Rendering Techniques> Standard** .

Glass House Options



You can modify the appearance of Glass House Views by selecting **3D> Rendering Techniques> Glass House Options**.

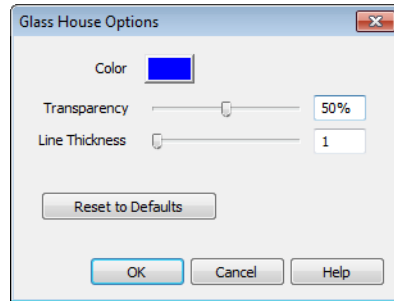

- Click the **Color** bar to select a color for the semi-transparent surfaces and lines in a Glass House view. See “Color Chooser Dialog” on page 309.
- Specify the **Transparency** of the surfaces in Glass House view. For example, to create a wireframe line drawing of your structure, turn transparency to full and minimize line thickness.
- Specify the **Line Thickness** of surface lines in Glass House view.
- Click **Reset to Defaults** to restore the default settings used when the Glass House view was first created.

Speeding up 3D View Generation

Depending on the speed of your processor, how many cores your processor has, and your computer’s video memory, a 3D view may generate in a few seconds or less.

When you have a large, complex model with a lot of detail, it may take a few minutes to generate a 3D view of everything in the model. During this process, progress information may display in the Status Bar and in a message window.

There are several ways to speed up the generation time of views.

Turn Off Layers



The display of objects in 3D views can be turned on or off by layer in the **Display Options** dialog. Turning off the display of unneeded objects in 3D views can speed up 3D view generation time. See “Display Options Dialog” on page 60.

Halt Generation with Esc Key

Using the Esc key, you can interrupt the modeling process at any point and display the incomplete model “as is.” This is particularly helpful when you just need to reorient a model on the screen for a specific angle or view.

The Esc option allows you to place the view quickly, then press the F5 function key to refresh the display with all 3D faces intact.

Faster Rendering

To increase rendering speed, consider turning off some or all of the following options in the **Preferences** dialog. Bear in mind that render quality may be affected. See “Render Panel” on page 54.

Use **Optimizations** - Many video cards with OpenGL are capable of optimizing 3D views

for subsequent redraws. Use of this option varies from video card to video card.

In general, you should leave this option turned on unless you are experiencing crashes when rendering.

Surface Backdrop - For some OpenGL-accelerated video cards, this option

drastically increases rendering speeds. When turned on, this option creates surfaces that the backdrop is drawn on. When this option is turned off, the backdrop is send directly to the video card. For most modern video cards, Off is the recommended setting.

Dimensions

Home Designer Essentials provides a variety of dimensioning tools for measuring walls, doors, windows, and many other objects.

Dimensions can be used to accurately position objects relative to other objects. In addition, dimension lines and extensions can be selected and customized.

Chapter Contents

- Dimension Unit Defaults
- Dimension Defaults Dialog
- The Dimension Tools
- Displaying Dimension Lines
- Editing Dimension Lines
- Editing Extension Lines
- Moving Objects Using Dimensions
- Dimension Line Specification Dialog

Dimension Unit Defaults

All plan files save measurements in either Imperial or metric units. The type of unit used is determined when the file is first

created and cannot be changed later. See “Creating a New Plan” on page 32.

Dimension Defaults Dialog



Select **Edit > Default Settings**, select “Dimension”, and click the **Edit** button to open the **Dimension Defaults** dialog.

The settings in this dialog are dynamic defaults, which means that any changes

made here may affect existing dimension lines in the drawing that are using default values. See “Dynamic Defaults” on page 48.

Setup Tab

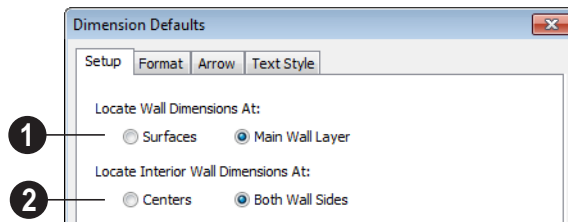

1 Specify how Manual and Auto Exterior Dimension lines locate both interior and exterior walls.

- Select **Surfaces** to have dimensions locate the outer surfaces of walls.

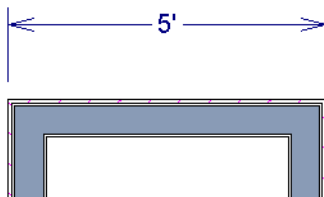

Dimensions locating wall Surfaces

- Select **Main Wall Layer** to have dimensions locate the structural layer of exterior walls.

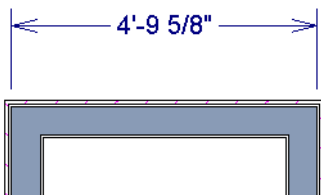

Dimensions locating walls' Main Wall Layers

2 Specify how Manual and Auto Exterior Dimension lines locate interior walls.

- Select **Centers** to have exterior dimensions locate the centers of interior walls.

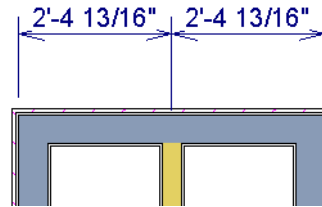

Dimensions locating an intersecting wall's center

- Select **Both Wall Sides** to have dimensions locate both sides of interior walls. Either the wall Surfaces or both sides of the Main Wall Layers will be located, depending on your selection above.

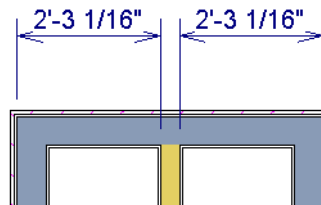

Dimensions locating an interior wall's Main Wall Layer

You can always change the object or surface that a dimension locates after it has been created. See “Editing Extension Lines” on page 349.

Format Tab

The settings on the Format tab allow you to specify the units, degree of accuracy and position of dimension numbers.

the Status Bar. See “The Status Bar” on page 23.

The settings on this tab also control the format of numbers indicating object length in

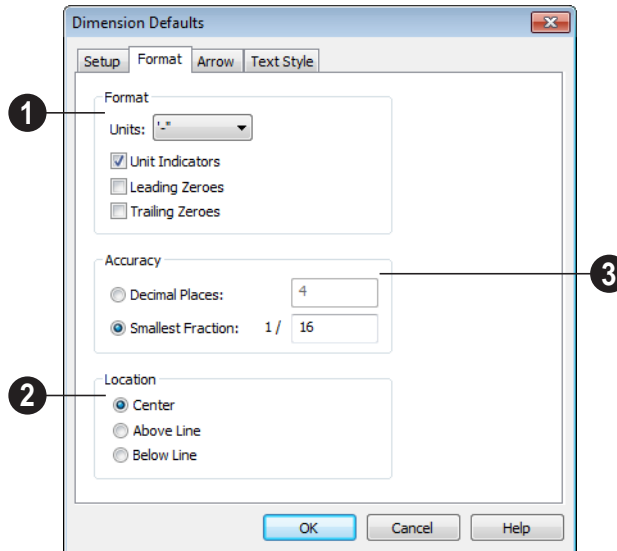

- 1 Specify the numbering **Format** for dimension numbers.
 - Select the **Units** of measurement to be used by dimensions from the drop-down list.
 - Check **Unit Indicators** to display the unit of measurement along with the dimension number.
 - Check **Leading Zeros** to include the zero before a decimal less than 1 or to display 0' or 0" when the ft-in or '-"' unit formats is used.
 - Check **Trailing Zeros** to display trailing zeros at the end of decimal values. When

the ft-in or '-"' unit formats is used and fractional inches are specified, 0" will be included.

- 2 Specify the **Location** of dimension numbers relative to the dimension line.
 - **Center** primary dimension numbers on the dimension line. If two formats are used, the primary format is placed above the line and the secondary format, beneath it.
 - Position dimension numbers **Above Line**.
 - Position dimension numbers **Below Line**.

- 3 Specify the degree of **Accuracy** used by dimension numbers.
- Select the **Decimal Places** radio button for dimension numbers in decimal format. In the text field, specify the number of decimal places to use, from 0 to 20. If 0 is used, no decimal places are used.
- Select the **Smallest Fraction** radio button for dimension numbers using whole numbers and fractions. In the text field, specify the largest denominator to use, from 1 to 128. If 1 is entered, whole numbers are used.

Arrow Tab

For information about the Arrow tab, see “Arrow Tab” on page 364.

Text StyleTab

The settings on the Text Style tab control the size, font and other attributes of automatic, manually drawn, and temporary dimension line labels. See “Dimension Labels” on page 347.

For information about the settings on this tab, see “Text Style Tab” on page 359.

Temporary dimension labels always use the color assigned to their layer - not the color specified in the **Dimension Defaults** dialog.

The Dimension Tools



Select **CAD> Dimensions** to access the Dimension Tools. Manually drawn dimensions are created by clicking and dragging like other line-based objects and can be drawn in floor plan view.

The zoom factor of the current view affects whether objects drawn close together are dimensioned or not. If you try to dimension an array of objects but the dimension line locates only the first and last objects along its path, **Zoom**  in on the objects and try again. Similarly, if you want to dimension between two objects but the dimension locates unwanted objects between them,

Zoom  out. See “Zoom Tools” on page 311.

Once created, both manually drawn and automatically generated dimension lines can

be selected and edited. See “Editing Dimension Lines” on page 347.

Manual Dimensions



To display the distance between two objects, select **CAD> Dimensions> Manual Dimension** and drag a dimension line near or through the objects.

Manual Dimensions locate walls as specified in the **Dimension Defaults** dialog. See “Dimension Defaults Dialog” on page 342.

End-to-End Dimensions



Use the **End-to-End Dimension** tool to dimension between any two defined objects in floor plan view.

Select **CAD> Dimensions> End-to-End Dimension** , then click and drag the

dimension from the first object to the second object. The dimension line snaps to each object, ignoring any other objects located between either end.

Auto Exterior Dimensions



The **Auto Exterior Dimension** tool generates dimensions around a plan's exterior in floor plan view.



Auto Exterior Dimensions do not generate properly if there is a gap in the exterior walls. For example, sometimes angled walls may not connect properly.

Auto Exterior Dimension  locate walls as specified in the **Dimension Defaults** dialog. See “Dimension Defaults Dialog” on page 342.

If you edit an **Auto Exterior Dimension**  line, it will be converted to a manual dimension, so if Auto Exterior Dimensions are later regenerated, your changes will not be lost.

There are a maximum of three rows of automatically generated dimensions per exterior wall direction. The innermost dimension line locates exterior walls, interior walls, and all openings in exterior walls. The second dimension line locates exterior and interior walls. The outermost dimension line is the overall exterior dimension.

Temporary Dimensions

Temporary Dimensions display when an object is selected and show the distance between the object's selected edge and other objects.

As with other dimension lines, Temporary Dimensions only locate objects that are parallel or nearly parallel to one another. They will also locate the endpoints of the corners of objects located past the end of the selected edge, within 4 feet (1200 mm) of the point where you click to select the object.

A temporary dimension will not display when an object is selected if a manually drawn dimension line is already present that shows the same information.

Tape Measure



Use the **Tape Measure** tool to draw a temporary dimension line between any two points in the drawing area. The tool will place temporary markers at the start and end points of the dimension line. These points and the line both disappear when you release the mouse button. If an object is located by the temporary line, you can snap to it.

The **Tape Measure**  tool can be used in cross section/elevation views as well as in floor plan view. See “Elevation Views” on page 322.

Displaying Dimension Lines

The display of dimension lines is controlled in the **Display Options** dialog. See “Displaying Objects” on page 59.

Dimension lines created by any of the dimension tools share the same components.

- **Dimension Lines** run parallel with the distance being measured.
- **Extension Lines** are perpendicular to dimension lines, indicating what they locate. If a dimension line locates more than two objects, extension lines divide the dimension line into segments.
- **Arrowheads** display at the intersections of dimension and extension lines.
- **Dimension Labels** display at the mid-point of dimension line segments and indicate the distance that each segment measures.

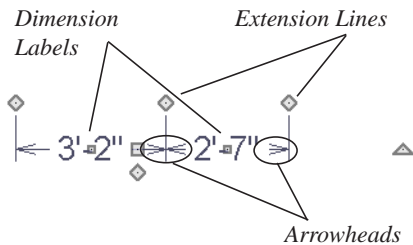

If a manual dimension line is on a layer that is turned off and you select an object located by that dimension line, it will display for reference in grey.

Dimension Labels

Manually drawn, automatic and temporary dimension labels use the Text Style specified in the **Dimension Defaults** dialog.

Dimension Arrowheads

You can specify the style, color and size of dimension arrows in the **Dimension Defaults** and **Dimension Line Specification** dialogs. See .

The arrow at the end of a dimension line will not display if it is close enough to another dimension arrow that the two will overlap. A typical example of this is where two sections of a dimension locate two sides of an interior wall.

Editing Dimension Lines

With the exception of Temporary Dimensions, dimension lines can be selected and edited using the mouse and the edit toolbar buttons.

If an Auto Exterior Dimension line is edited, it will no longer be considered an automatic dimension line and will not be deleted and replaced the next time the **Auto Exterior**

Dimensions  tool is used.

Dimension line numbers and extension lines can be individually selected, moved and

deleted, and new extension lines can be added. See “Editing Extension Lines” on page 349.

Using the Mouse

When a dimension line is selected, its edit handles can be seen. There are four types of dimension line edit handles. More than one of some types display, depending on how many extension lines are present.

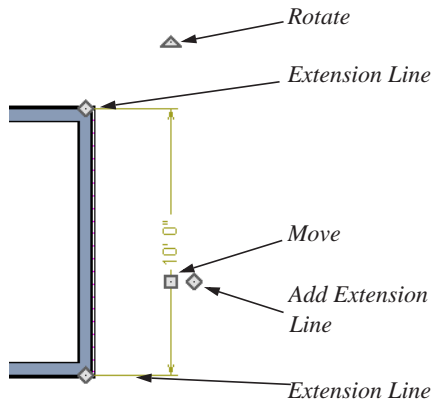

- The **Extension Line** handles mark the location being dimensioned and are used to move or delete extension lines. See “Moving Extension Lines” on page 349.
- The **Add Extension Line** handle displays to the side of the Move handle and is used to add extension lines to the dimension line. Dimension lines do not extend unless an object can be located. See “Adding Extension Lines” on page 349.
- The small, square **Move Dimension Label** handle is located at the center of the selected label. Use this handle to move the dimension number for each dimension line section. The pointer changes to a four-headed arrow \leftrightarrow when moved over this handle.
- The **Move** handle is located where you clicked to select the dimension line and is used to move the entire dimension line, including any subsections, perpendicular to itself. Extension lines are resized as appropriate. The pointer changes to a two-headed arrow \leftrightarrow when moved over this handle.

- The **Rotate** handle is located one plan foot past the end of the dimension line and is used to rotate the dimension line.

Using the Edit Tools

Dimension lines can be repositioned, copied, and deleted using the edit toolbar buttons just like other objects in the program can. See “The Edit Toolbar” on page 21.

Dimension Number Size

The initial size of dimension numbers is specified in the **Dimension Defaults** dialog. See “Dimension Defaults Dialog” on page 342.

You can specify number height for individual dimension lines in the **Dimension Line Specification** dialog. See “Dimension Tab” on page 352.

As with text and other objects, dimension number size is subject to scaling when or printed.

Copying and Pasting Dimension Lines

Dimension lines can be copied and pasted into any view type that supports dimensions. If a dimension line is copied independent of the objects it originally locates, the pasted dimension line will locate point markers.

Deleting Dimension Lines

There are several ways to delete dimension lines.

You can select any manual or automatic dimension line or group of dimension lines, then press the Delete key or click the

Delete  edit button. See “Deleting Objects” on page 93.

The **Delete Objects** dialog allows you to delete all manually drawn and/or automatic dimension lines at once. See “Delete Objects Dialog” on page 93.

Individual dimension line segments located between extension lines can also be deleted. If a segment is located between two other

segments along the same dimension line, that dimension will be broken in two.

To delete a portion of a dimension line

1. Select any **Dimension Tool** aside from Auto Exterior Dimensions.
2. Click and drag a manual dimension line over the segment that you wish to remove, dragging from extension line to extension line.

Editing Extension Lines

Extension lines can be added, edited, and deleted using the mouse.

Adding Extension Lines

To add an extension line

1. Select the dimension line.
2. Click the diamond-shaped Add Extension Line edit handle which displays near the Move edit handle. The pointer changes to a two-headed arrow ↔.
3. Drag the handle to the object that you want to locate with a new extension handle. This example adds an extension line to the window edge.

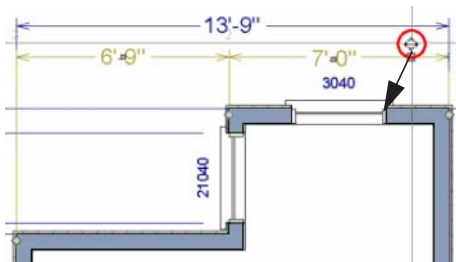

4. Release the mouse button to add an extension line.

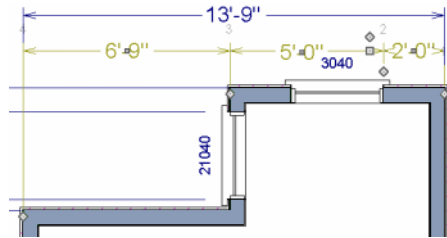

Moving Extension Lines

Extension lines can be moved to locate the centers, sides, or surfaces of most objects. In this example an extension line is moved from the windows edge to the center.

To move an extension line

1. Select the dimension line it is connected to, not the extension line itself.
2. Click the Extension Line edit handle. The pointer changes to a two-headed arrow ↔.

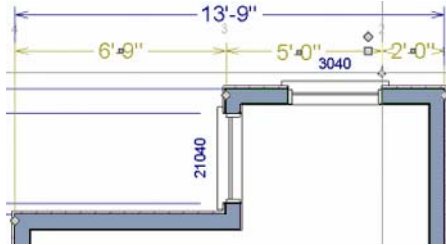

3. Drag the handle to a new location. The extension line snaps to possible marks as the handle is moved.
4. Release the mouse button at the new location.

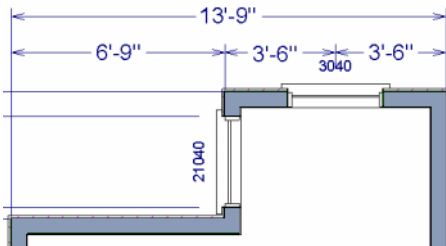

 Not all library symbols can be located by a dimension line as it is drawn. Once a dimension is drawn, however, you can move or add an extension line to locate the library object.

Deleting Extension Lines

When an extension line is deleted, the remaining dimensions update. If a dimension line has only two extension lines, they cannot be deleted.

To remove an extension line

1. Select the dimension line it is connected to, not the extension line itself.
2. Click the Extension Line edit handle.

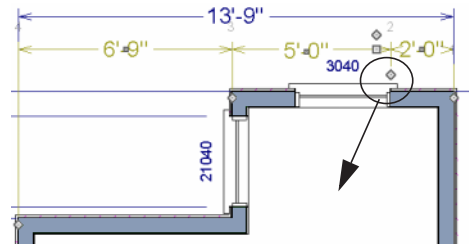

3. Drag it perpendicular to the direction of the arrows, away from any dimension-able object, and release the button when the extension line disappears.

Moving Objects Using Dimensions

Most objects can be moved by changing an automatic, manual or temporary dimension value that locates it. This technique can be applied in nearly any situation where dimensions are present. See “Moving Objects” on page 88.

In addition, some objects can be resized using dimensions. See “Resizing Objects” on page 90.

Your pointer indicates which dimensions can be used to relocate the selected object by changing to a pointing hand icon.

Another way to tell is to select an object and drag it in the desired direction. As you drag,

note which dimensions update. These dimensions are the dimensions that can be used to move that object.

To move an object using dimensions

1. Select the object and click on a dimension line that locates it. An inline text field opens at the location where you clicked.
 - The actual distance displays in the text field.
 - If the dimension is locating two different objects, the **Move Edge** and **Move Entire Object** buttons display to the right of the text field.

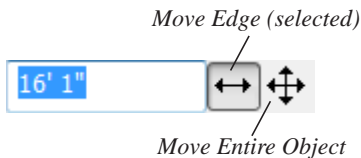

- If the dimension describes a selected wall's length, the **Move Start**, **Move End** and **Move Both Ends** buttons display to the right instead.

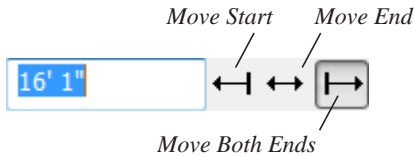

2. Click the **Move** button of your choice.
 - To use a different unit, include its indicator after the value. To move the
3. Enter a new value in text field.
 - To use a different unit, include its indicator after the value. To move the

selected object past a second object, to its opposite side, enter a negative value.

4. The selected object moves or resizes when you press the Enter key or click outside of the text field.

To resize an object using dimensions

1. Select the object along the edge that you would like to move. See “Selected Edge” on page 71.
2. Click on a dimension line that indicates its distance from the object's opposite side.
3. In the inline text field, enter a value.
4. Click **Move edge** to move the selected edge only.
5. The selected edge moves, resizing the object, when you press the Enter key.

 You can cancel a move or resize operation using dimensions at any time by pressing the Esc key.



Resizing a House Using Exterior Dimensions

When resizing a house using dimensions, it is important to work your way around the house in one direction. Relocate one wall at a time in succession so that you do not redefine the same dimension more than once.

For more information, see “Adjusting Wall Positions” on page 33 of the User's Guide.

Dimension Line Specification Dialog



To open the **Dimension Line Specification** dialog, double-click a dimension line using the **Select Objects**  or **Manual Dimension**  tool, or select a

dimension line and click the **Open Object** edit button.

The settings in this dialog are dynamic defaults. See “Dimension Defaults Dialog” on page 342.

Dimension Tab

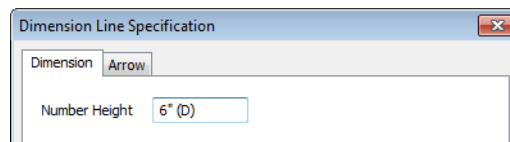

Specify the **Number Height** for the selected dimension. Type “d” in the box to reset the number size to the default.

Arrow Tab

For information about the settings on this tab, see “Arrow Tab” on page 364.

Text

Text is an ideal way to draw attention to special details of your drawings in floor plan view.

Text lines with arrow can be attached to text objects, allowing you to direct attention to specific plan details.

Chapter Contents

- Fonts and Alphabets
- The Text Tools
- Creating Text
- Displaying Text
- Rich Text Specification Dialog
- Text Specification Dialog
- Editing Text
- Copying & Pasting Text
- Text Arrows
- Line/Polyline Specification Dialog

Fonts and Alphabets

Home Designer Essentials allows you to use any font found in your Windows Fonts directory.

International Alphabets

The **Rich Text**  tool supports unicode alphabets and characters. In order to use a unicode alphabet or characters, the appropriate language support must be installed on your computer.

Special characters can be added to any **Rich**

Text  object by:

- Copying and pasting the character from another application;
- Copying and pasting the character from the Windows Character Map;
- Typing the keystroke associated with the character.

See “Copying & Pasting Text” on page 361.

The Text Tools



Select **CAD> Text** to access the **Text Tools**. These tools are available in floor plan view only.



The **Rich Text** tool is used to create text objects.



The **Text Line with Arrow** tool is used to connect text and another object with an arrow. See “Text Arrows” on page 362.



Text with Arrow tool places a Rich Text object with an arrow attached.

Creating Text

Text can be created in floor plan view only.

Once created, text can be selected and edited in a variety of ways. See “Editing Text” on page 360.

To create Rich Text

1. Select **CAD> Text> Rich Text** .
2. Type or paste the desired text into the Text Field.

3. Use the options to change the font, style and size of any portion of the text.

Note: If you do not type anything in the Text Field, a text object will not be created when you click outside of it.

You can also create lines with arrows connecting the text that you create to items in the drawing. See “Text Arrows” on page 362.

Displaying Text

As with other types of objects, the display of Text objects is controlled in the **Display Options** dialog. All Text objects, including Text Lines with Arrows, are located on the “Text” layer. See “Display Options Dialog” on page 60.

Text objects can only be displayed in floor plan view.

The display attributes of each individual text object can be controlled independent of the layer it is placed on. See “Rich Text Specification Dialog” on page 355.

Rich Text Specification Dialog



The **Rich Text Specification** dialog opens if you select the **Rich Text**  tool and then click once in the drawing area.

You can also open this dialog by selecting a **Rich Text**  object, then clicking the **Open Object** edit button.

Text Tab

The settings on the Text tab allow you to type the selected Rich Text object's content and control many aspects of its appearance, including its font, size, color and style.

You can specify the appearance of the text before typing, and can also select and change

the attributes of all or portions of the text content after it is typed. To change text that already exists, simply highlight it using the mouse and/or the Shift + arrow keys and then make any needed changes to its attributes.

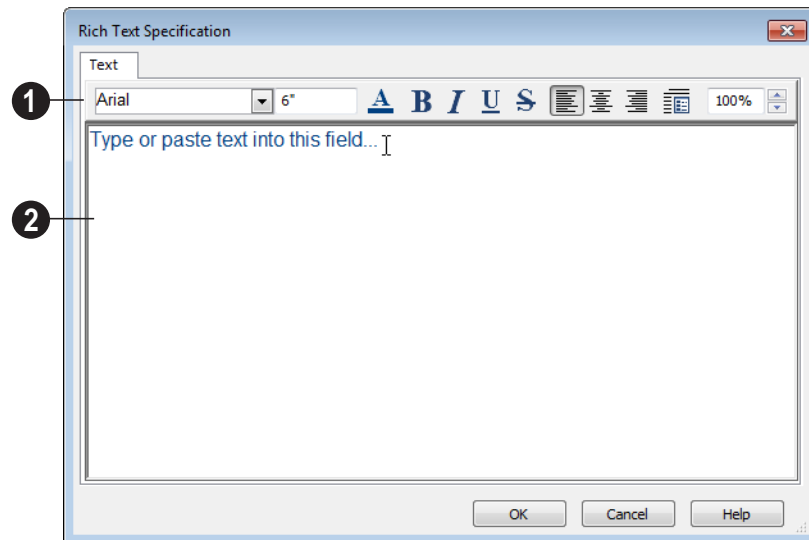









1 Use the options on the Edit Bar, which displays above the Text Entry field, to change the font, style and size of the text.

Select the desired options before typing to affect the text as it is typed, or select some or all of the text and then specify which options to apply to it.

- Select a **Font** from the drop-down list.
- Specify the **Text Size** in drawing units. When imperial Inches or Feet and Inches are used, accuracy to 1/128" is possible.
- Click the **Color**  button to specify the color of the selected or subsequently

typed text. See “Color Chooser Dialog” on page 309.

- Click the **Bold**  button to specify the selected or subsequently typed text as bold.
- Click the **Italic**  button to specify the selected or subsequently typed text as italic.
- Click the **Underline**  button to specify the selected or subsequently typed text as underlined.

- Click the **Strikethrough**  button to selected or specify the subsequently typed text as stricken-through.
- Click the **Align Left** , **Align Center** , or **Align Right**  button to specify the how the selected or subsequently typed text is aligned.
- Click the **Paragraph Options**  button to specify the selected paragraph's alignment, spacing and bullets or numbering in the **Paragraph Options** dialog.
- Specify the **Zoom** factor of the selected text by typing a percentage value in the text field or clicking the up/down arrows. This setting only affects the text as it appears in this dialog.

Note: Some fonts cannot be drawn at certain zoom factors. When this is the case, the appearance of the text will not change.

- 2 Type or paste text in the Text Entry field. See “Copy, Cut and Paste” on page 361.

Right-click in the Text Entry field to access a contextual menu from which you can select Cut, Copy, Paste and Select All. See “Contextual Menus” on page 22.

To edit text in the entry field, click and drag to highlight any portion of it and then use the tools on the Edit Bar as needed.

Paragraph Options Dialog

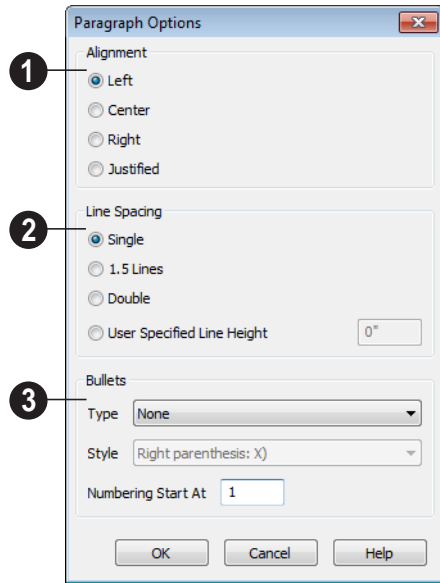

- 1 Specify the **Alignment** of the selected paragraph(s). See “Aligning Text” on page 361.
- 2 Specify the **Line Spacing** of the selected paragraph(s).
 - Click the radio button beside **Single**, **1.5 Lines**, **Double** or **User Specified**.
 - If you select **User Specified Line Height**, type the desired height for each line of text in the selected paragraph(s). For best results, this value should be at least as much as the largest character size used in the selected paragraph(s).
- 3 Specify the appearance of **Bullets** and numbering in the selected paragraph(s).
 - Select the desired bullet, numbered or lettered **Type** from the drop-down list.

- Select the desired punctuation **Style** for the selected numbered or lettered Type. Only available when a numbered or lettered Type is selected.
- **Numbering Start At** - Specify the number assigned to the first numbered or lettered paragraph in the selected text object. Value must be 1 or greater.

To adjust the size of bullets

1. Click at the end of a bulleted paragraph to position your cursor there.
2. Hold down the Shift key and press the right arrow key once to highlight the end of the paragraph.
3. Specify the desired bullet size in the text size field at the top of the Text tab.

Text Specification Dialog



The **Text Specification** dialog opens if you select a Room Label or a simple **Text** object in a legacy plan file created in Version 8 or prior and click the **Open Object** edit button. See “Compatibility with Other Programs” on page 31.

Settings in the **Text Specification** dialog can also be found in other dialogs in the program, including the **Room Label Specification** and the **Dimension Defaults** dialogs.

Text Tab

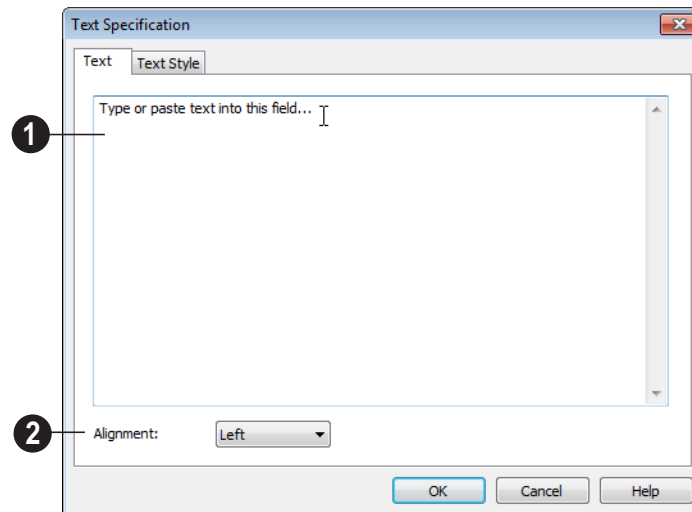

- 1 Enter text in the **Text Entry** field. This field is not available if the selected

object is a Room Label. See “Room Labels” on page 126.

- 2 Select an **Alignment** option from the drop-down list to apply to the text.

Text Style Tab

The Text Style is also available in a number of other dialogs in the program.

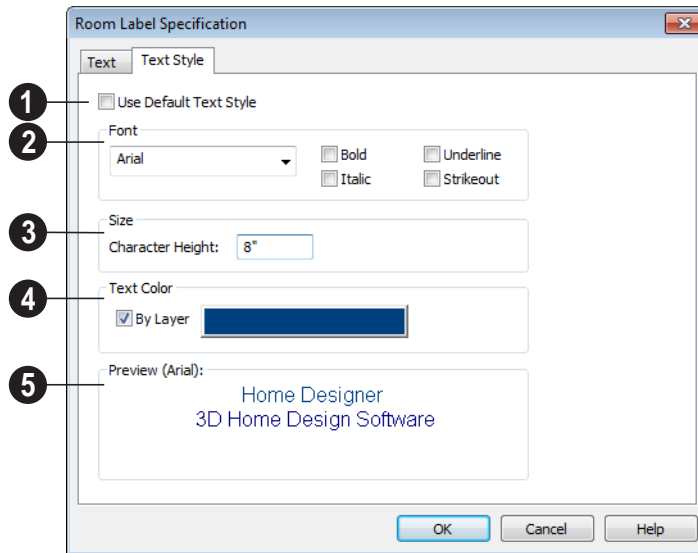

- 1 Uncheck **Use Default Text Style** to enable the settings that follow. When it is checked, information about the Text Style that is assigned to the selected object displays for reference.
- 2 Specify the attributes of the selected Text Style's **Font**.
 - Select a font from the drop-down list.
 - The text styles **Bold**, **Underline**, **Italic**, and **Strikeout** are available. Check any of the boxes to apply that style.
- 3 Specify the **Size** of text using the selected Text Style.
 - Enter the **Character Height** in drawing units. This height is subject to the current drawing scale. When imperial Inches or Feet and Inches are used, accuracy to 1/128" is possible.
- 4 Specify the selected Text Style's **Text Color**. When Use Custom Text Style is not selected above, a Text Color does not display here for reference.
 - When **By Layer** is checked, text uses the line color assigned to the layer it is located on. See "Layers" on page 58.

- Uncheck **By Layer**, then click the **Color** bar to select a different color. See “Color Chooser Dialog” on page 309.

- 5 A preview of the Text Style currently assigned to the selected object displays here.

Editing Text



Once created, **Rich Text**  objects can be selected individually or as a group and edited using the edit handles and the edit toolbar. Individual text objects can also be edited in the **Rich Text Specification** dialog. See “Rich Text Specification Dialog” on page 355.

Editing Text Attributes

Most text attributes, including the font, size, style, and the content itself, are edited in the **Rich Text Specification** dialog.

In order to edit the attributes of an existing **Rich Text**  object, you must select some or all of the text before making changes. See “Text Tab” on page 356.

To edit Rich Text attributes

1. Select a **Rich Text**  object and click the **Open Object**  edit button.
2. On the Text tab of the **Rich Text Specification** dialog, click and drag to select some or all of the text typed into the Text field.

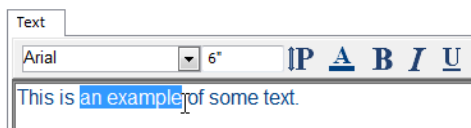

3. With some or all of the text selected, change any of the attributes available

along the top of the tab, including the font, size, color, and style.



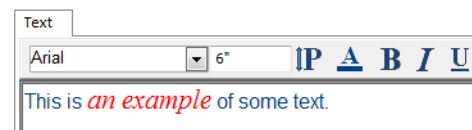

4. As changes are made, the selected text updates. Only the selected text is modified.



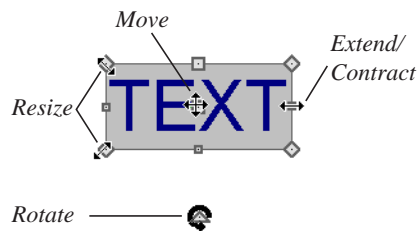

Using the Mouse

A selected **Rich Text**  object has the same edit handles as other box-based objects. See “Editing Box-Based Objects” on page 82.



As a **Rich Text**  box is made smaller using an edit handle, not all of the text may be visible.

Using the Edit Tools

A selected **Rich Text**  or **Text**  object can be edited in a variety of ways using the buttons on the edit toolbar. See “The Edit Toolbar” on page 21.

Resizing Text

The character height of **Rich Text**  objects can be specified in their specification dialogs.





Scaling Text

As with the size of other objects, text size is subject to the current drawing scale specified in the **Page Setup** dialog. See “Page Setup Dialog” on page 386.

Aligning Text

Text can be aligned in a couple of ways.

- The text content of a text object can be aligned to the left, right, center or justified in the **Rich Text Specification** dialog. See “Text Tab” on page 356.

- The text content of a text object can be also be aligned by clicking the **Align Left** , **Align Right** , **Center** , or **Justify**  edit button.

Copy, Cut and Paste

Copy, Cut and Paste of text into and out of the **Rich Text Specification** dialog can be accomplished using keyboard hotkeys:

- Press Ctrl + X to Cut the selected text and save it to the Windows clipboard.
- Press Ctrl + C to Copy the selected text and copy it to the Windows clipboard.
- Press Ctrl + V to paste your last cut or copied selection in a new text object.

For more, see “Copying and Pasting Objects” on page 66.

Copy, Cut and Paste use the Windows clipboard, making it possible to transfer text between text objects, between Home Designer Essentials files, from a plan into another application, or vice versa.

Copying & Pasting Text

The Copy, Cut and Paste commands use the Windows clipboard, making it possible to transfer text between text objects, between Home Designer Essentials files, from a plan into another application such as a text editor or spreadsheet program, or vice versa. See “Copying and Pasting Objects” on page 66.

All or selected portions of the Materials List can also be copied and pasted into a text

object, as well as into a word processing or spreadsheet program. See “Materials Lists” on page 392.

Cut, Copy, and Paste can also be accessed from the Edit menu of many applications, including Home Designer Essentials. These menu commands are not available when the text specification dialogs are open, but you can use the associated hotkeys.

To Copy, Cut and Paste text

1. On the Text tab of either text specification dialog or in another program altogether, highlight the text you wish to cut, copy or paste.
2. Press Ctrl + X to **Cut** the selected text out of its original location and save it to the Windows clipboard.
3. Press Ctrl + C to **Copy** the selected text to the Windows clipboard without removing it from its original location.
4. Open the text object or a file in another application and click to place your cursor in the Text field, writing area, or spreadsheet cell.
5. Press Ctrl + V to **Paste** the copied text at the location of your cursor.

Bear in mind that when text is copied and pasted, its formatting is not always retained. The results depend on the program or type of

text object in which the content was created as well as the type of text object into which it is pasted.

Pasting into Rich Text

Text pasted into a **Rich Text** object from another source will retain most of its custom formatting.

Text pasted into a **Rich Text**  object from a spreadsheet program retains basic column and row information. Column width cannot be adjusted; however, as you add or remove text from a cell, row height will increase or decrease to accommodate your changes.

The background colors of two or more cells copied from a spreadsheet application will be retained if pasted in to **Rich Text** ; however, once pasted background color cannot be edited.

Text Arrows

Text arrows can be used to connect text objects to details of interest in your drawing.

Text arrows can be snapped together to form open or closed polylines. If two lines with arrows meet within the bounding box of a text object, however, they will not join. This allows you to attach multiple, separate text arrows to a single text object. See “Editing Line Based Objects” on page 73.

Lines with arrows can be independent or attached to other objects. Arrows attach to closed polyline-based objects along their edges, but can attach to an architectural object anywhere within its 2D symbol in floor plan view. If an arrow is attached to text

or another object, deleting either the text or the object will also delete the arrow.

Text with Arrow

The **Text with Arrow** tool places a text object with an arrow already attached. This arrow can be selected and edited like any other arrow.

Text Line with Arrow

Text Lines with Arrow can be attached to text and architectural objects by selecting **CAD> Text> Text Line with Arrow**  and then clicking and

dragging to draw a line. There is no limit to the number of text lines with arrows that can be attached to an object.

The endpoints of **Text Lines with**

Arrows  can be joined to form polylines with corners that can be adjusted using the edit handles.

Auto Positioning Arrows

There are four auto position locations on a text object: one at the midpoint of each side.

The following image illustrates the behavior of auto positioning. When the head of the

line with arrow is moved, the tail of the arrow snaps to different auto position locations on the text object, maintaining its connection.

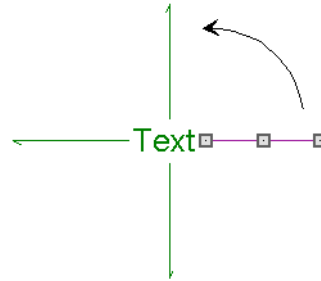

Line/Polyline Specification Dialog



Select a Text Line with Arrow and click the **Open Object** edit button to open the **Line Specification** dialog, **Arc Specification** dialog (if the line has been curved) or the **Polyline Specification** dialog (if the object is composed of multiple line and/or arc segments).

The settings in these dialogs are similar to those available for a variety of other objects in the program.

Polyline Tab

The Polyline tab is available when the selected object is composed of more than one line or arc segment and displays the Length/Perimeter, Area, and Volume of the selected polyline. The Area and Volume of open polylines are described as “Not closed”.

Selected Line Tab

The Selected Line tab is available when the selected edge of the polyline is a line as opposed to an arc. See “Selected Edge” on page 71.

The settings on the Selected Line tab are available for a variety of other objects in the program. For information about these settings, see “Selected Line Tab” on page 222.

Selected Arc Tab

The Selected Arc tab is available when the selected edge of the polyline is a line as opposed to a line. See “Change Line/Arc” on page 92.

The settings on the Selected Line tab are available for a variety of other objects in the program. For information about these settings, see “Selected Arc Tab” on page 223.

Line Style Tab

The settings on the Line Style tab are available for a variety of other objects in the

program. For information about these settings, see “Line Style Tab” on page 225.

Arrow Tab

The Arrow tab is available for open polylines, but not for closed polylines.

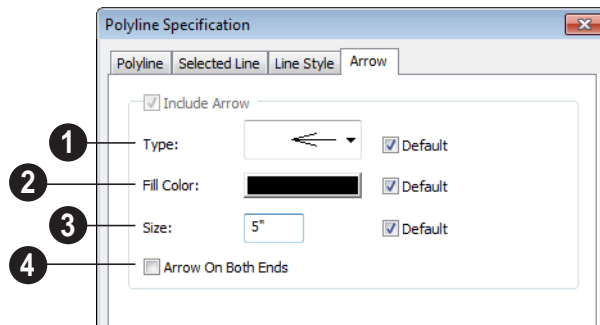

- 1 Select an arrowhead **Type** from the drop-down list.

Check **Default** to reset the arrow type.

- 2 Select the **Fill Color** used to fill the arrowheads. See “Color Chooser Dialog” on page 309.

Check **Default** to reset the fill color.

- 3 Define a **Size** for the arrow(s).

Check **Default** to reset the size.

- 4 Check **Arrow on Both Ends** to place a head on both ends of the selected arrow(s).

Fill Style Tab

The Fill Style tab is available for closed polylines, but not for open polylines.

The settings on the Fill Style tab are available for a variety of other objects in the program. For information about these settings, see “Fill Style Tab” on page 225

Project Planning

The tools described in this chapter let you draw plans with ease and flexibility and run checks on plans so you can be more confident that they are free of common drawing errors.

Chapter Contents

- House Wizard
- Plan Check

House Wizard

 The **House Wizard** is a time-saving feature used to create a preliminary room-by-room design of a home without getting caught up in the details. Once the shape and layout of the rooms are finalized, the **House Wizard** converts them into a working plan that can be edited and detailed to completion.

Start House Wizard

 Select **Tools> House Wizard> Start House Wizard**. The **House Wizard** leads you through a series of windows that gather information about the rooms you want to include in your house. When you click **Finish** and close the **House Wizard**, the selected room boxes display.

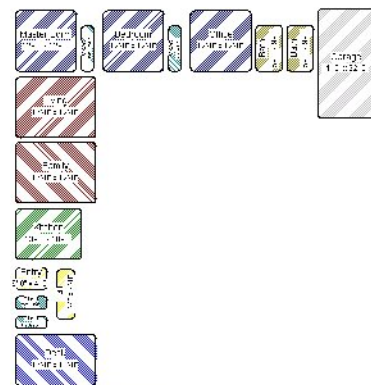

Room boxes can now be arranged into a floor plan.

Placing Room Boxes

In addition or as an alternative to the room boxes created for you by the **House Wizard**, you can create your own room boxes. To do so, select **Tools> House Wizard** , then choose the desired room type from the submenu. Click in floor plan view to place a room box of the selected type at that location.





Displaying Room Boxes

Room boxes and their labels are located on the “House Wizard Room Boxes” layer. Room box labels use the Text Style assigned to that layer, as well. See “Displaying Objects” on page 59.

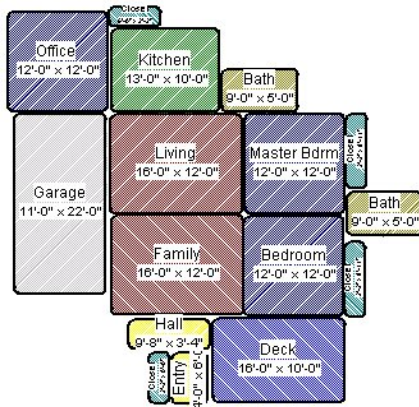
Editing Rooms

Once created, room boxes can be edited in a variety of ways.



- Select room boxes using the **Select Objects**  tool just like other objects in Home Designer Essentials. See “Selecting Objects” on page 71.
- Room boxes can be resized, rotated, and rearranged. See “Editing Box-Based Objects” on page 82.
- Try to line up the rooms so that they are just touching. Excessive overlaps may cause your rooms to form incorrectly. Closets are the exception. You can overlap a room with a closet, or place inside another room box.
- Rooms can be copied and pasted using the **Copy/Paste**  edit button and deleted using the **Delete**  edit button.
- Select **Tools> House Wizard**  to access the room box tools and place additional room boxes in your plan. Select a tool and click in the plan to place a room box of that type.
- Select **Tools> House Wizard> Hide Room Boxes**  to hide or show the room boxes.

Build House

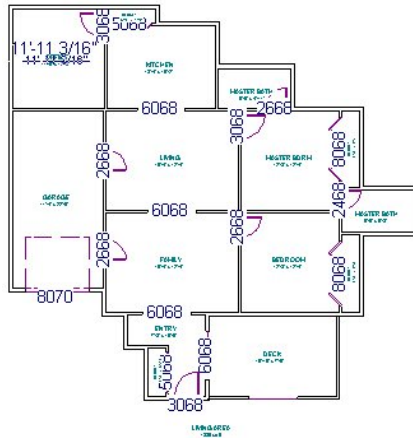

When the rooms are in place, select **Tools> House Wizard> Build House**  to convert the rooms into a building model. Walls and doors are inserted between the rooms that you arranged.

Multiple Floors



When you Build House, the “House Wizard Room Boxes” layer is automatically turned off. The room boxes that you created are not deleted, however.

If you specified a two-story house, follow these steps:

1. Edit and arrange the room boxes on Floor 1 as desired.
2. Select **Tools> House Wizard> Build House**  tool to create the walls on the first floor.
3. Go **Up One Floor**  and notice that the positions of the walls on Floor 1 display in red as a reference.
4. Arrange the rooms on Floor 2 as desired, using the reference display as a guide.
5. On the second floor, select **Tools> House Wizard> Build House**  to complete the second floor.

Plan Check



Plan Check checks the floor of your plan currently shown on screen for anything that appears to violate common building practices. Plan Check may not find all the problems in a plan, but does it point out areas that may need improvement.

As your plan evolves, a number of things that may become incorrect can be fixed using Plan Check. For example, doors that change from exterior to interior as you add new rooms are redrawn without the threshold line that marks an exterior door. A cabinet, fixture or furniture item that is against a wall because the wall was moved into it, as

opposed to the item moving, are attached to the wall.



Disclaimer: The Plan Check feature in Home Designer Essentials compares your plan with common building practices. Plan Check does not claim to detect all building code and design requirements. Always have your plans checked by a licensed professional before beginning actual construction.

To run Plan Check, select **Tools> Plan**

Check .

Plan Check Dialog

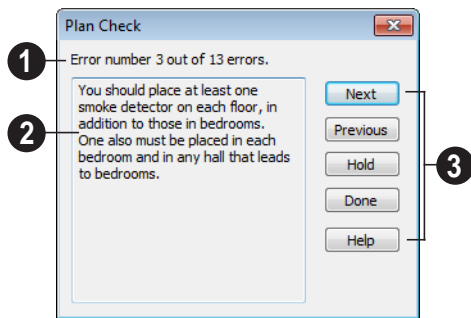

- 1 The current error number, along with the total number of errors found.
- 2 A description of the current error displays here.
- 3 Options for navigating Plan Check are found on the right side.
 - Click **Next** to ignore the current error and proceed to the next.
 - Click **Previous** to return to the previous error.
 - Click **Hold** to suspend Plan Check so you can fix the current error. Select **Tools> Checks> Plan Check** again and the check starts where it left off.
 - Click **Done** to terminate Plan Check.

Potential plan errors found are usually highlighted in floor plan view. To ensure the highlighted item is on-screen, make sure the entire plan is shown in the window before

you run **Plan Check**

If this dialog obscures the floor plan view, drag its title bar to move it. It remembers its new position and displays there the next time

Plan Check is run.

Room Types

Plan Check can do a much better job of checking for problems if it knows what the rooms in your plan are to be used for, so you should assign a Room Type to each room in your plan. See “Room Types” on page 124.

The first time **Plan Check** runs in a plan, it automatically assigns a room type to as many undesigned rooms as it can. Some rooms are determined by their size and shape, and others by their contents. For example, a shelf in a small room indicates a closet; a stove or refrigerator indicates a kitchen; or a bed, a bedroom. If the program cannot assign a room type, **Plan Check** highlights it and suggests that you do so manually.

Pictures, Images, & Walkthroughs

Home Designer Essentials uses picture files in a variety of ways to enhance your drawings.

The Library Browser contains images of real world objects like plants, vehicles, and people that can display in 3D views.

Picture files can also be imported into Home Designer Essentials and shown in most views.

You can save any view using a variety of picture file formats. In addition, Home Designer Essentials allows you to create virtual tours that can be saved as **.avi** files, shared with others, and played back later.

Chapter Contents

- Picture Files vs Pictures and Image Objects
- Images
- Displaying Images
- Editing Images
- Image Specification Dialog
- Pictures
- Picture File Box Specification Dialog
- Metafiles
- Metafile Box Specification Dialog
- Displaying Pictures and Metafiles
- Editing Pictures and Metafiles
- Copy Region as Picture
- Walkthroughs

Picture Files vs Pictures and Image Objects

In common computer language, picture files, pictures and images are more or less synonymous. In the Home Designer Essentials environment, however, there are some notable differences between these terms.

In Home Designer Essentials, a two dimensional image file such as a .bmp, .jpg, .gif, or .png is referred to as a picture file or an image file. Examples of these files are saved on most computers and can be opened in a variety of applications.

A Picture, on the other hand, is a file that has been imported into the program. Pictures can be imported into floor plan view and Elevation views. They are two-dimensional

only and do not display in camera views or overviews.

An Image object is also based on a picture file, but it does display in both 2D and 3D views. Images have 3D width and height data associated with them, as well as a 2D symbol which displays in floor plan view.



Picture files have additional uses in Home Designer Essentials, as well:

- Backdrops are picture files that display behind 3D views. See “3D Backdrops” on page 324.
- Textures are picture files that realistically represent materials in 3D views. See “About Materials” on page 300.

Images

Images add realistic detail to 3D views without adding many surfaces to the model. For example, a tree image with a single surface can be used instead of a tree symbol with thousands, dramatically improving realism without compromising drawing time.

There are two types of Images in Home Designer Essentials:

- **Images**  rotate so that they always face the camera in 3D views.
- **Billboard Images**  do not rotate to face the camera. An example of when this may be useful is an image of a trellis, which might look awkward when facing a camera from a side view.

Placing Images



A selection of Images are available in the Library Browser. Select one and click in a floor plan view, camera view or overview to place it. See “Placing Library Objects” on page 293.

Creating Images





Custom Images can be added to the Library Browser, as well as created in plan files. Home Designer Essentials can use any image with a *.bmp, *.jpg, *.png, *.gif, *.tif, *.pcx, or *.tga extension.

Generally, .png files work best as Images because this format has good compression

and allows for the Image to contain transparency information.

To create an Image in floor plan view

1. In floor plan view, select **Build> Image> Create Image**  or **Billboard Image**  to open the **Image Specification** dialog. See “Image Specification Dialog” on page 373.
2. On the Image tab:
 - Click the **Browse** button to select a picture file on your computer or enter the path to a valid picture file in the **Image File** field.
 - Select or 2D plan symbol to represent the image in floor plan view. Choose a **2D Plan Symbol** from the list or click the **Library** button and select a symbol from the library. See “Image Tab” on page 374.
 - Enter **Height** and/or **Width** and **Location** information.
3. Specify transparency information on the Transparency tab.

4. Click OK to close the **Image Specification** dialog.
5. Click to place the new Image in floor plan view.

To create an image in the Library Browser

1. In the Library Browser, right-click on an unlocked folder.
2. Select **New> Image** from the contextual menu to open the **Image Specification** dialog.
3. Browse to the image file you want to add and select your other options. See “Image Specification Dialog” on page 373.
4. Once created, the image is listed in the library folder that you right-clicked on. Size and other data is saved.

Using Paste Image



You can also import an image by first copying it to the Windows Clipboard, then navigating to a Home Designer Essentials window and selecting **Edit> Paste> Paste** from the menu. See “Paste Special” on page 68.

Displaying Images



The display of images in floor plan and 3D views is controlled in the **Display Options** dialog. See “Displaying Objects” on page 59.

Images are placed on the “Images” layer.

In Floor Plan View

In floor plan view, most images are typically

represented by an Image  symbol. You can specify a different symbol to represent an image if you wish. See “Image Specification Dialog” on page 373.

In 3D Views

The actual picture associated with an image object can be seen in 3D views. It is sized

according to its Width and Height specifications. Any transparency data associated with the image is also applied. See “Image Specification Dialog” on page 373.

Images can be set to either rotate so that they always face the camera or to remain stationary, like billboards. See “Images” on page 371.

Editing Images

Images can be selected in 2D and 3D views and edited using the edit handles, edit tools and the **Image Specification** dialog.

Using the Mouse

Images can be resized in floor plan view by dragging the circular Resize handle at the top of the 2D symbol.

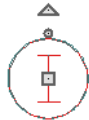

Images can also be resized in 3D views by dragging the circular Resize edit handle at the top.



When an image is resized, the aspect ratio of the image and its 2D symbol are retained, so the image resizes proportionally.

Using the Edit Tools

A selected image or images can be edited in a variety of ways using the buttons on the edit toolbar. As with most objects, images can be copied, replicated, moved, deleted, etc. See “The Edit Toolbar” on page 21.

Image Specification Dialog



Select an image and click the **Open Object** edit button to open the **Image Specification** dialog.

Image Tab

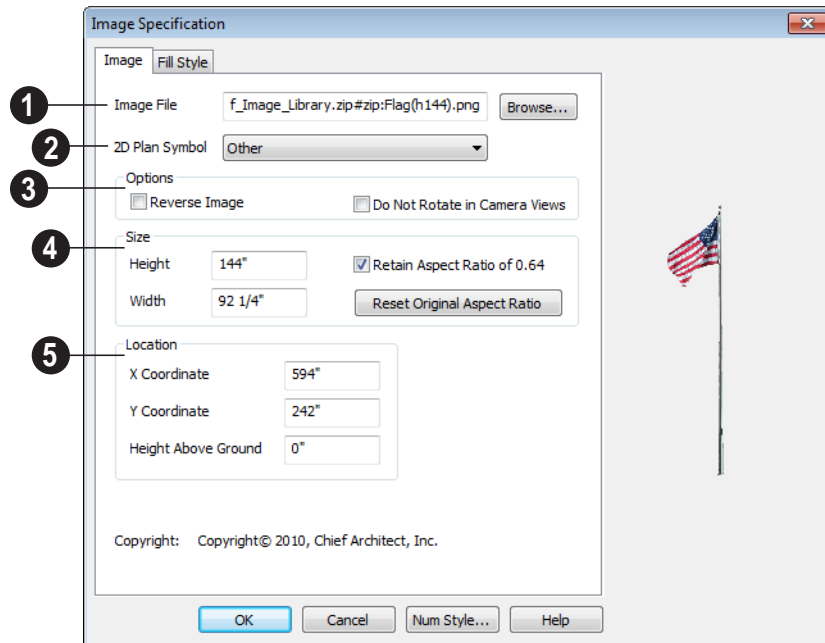

- 1 **Image File** - The path and name of the selected Image. You can click **Browse** to replace the current image file with a different one saved on your computer.
- 2 Select a **2D Plan Symbol** from the drop-down list to represent the Image in floor plan view. See “Displaying Images” on page 372.
- 3 **Options**
 - Check **Reverse Image** to reflect the appearance of the image about an imaginary vertical line through its center.
 - Check **Do Not Rotate in Camera Views** to prevent the image from rotating to face the camera in 3D views. This box is checked for Billboard Images. See “Images” on page 371.
- 4 Specify the **Size** of the image as it displays in 3D views.
 - Enter a **Height** for the selected image.
 - Enter a **Width** for the selected image.
 - When **Retain Aspect Ratio of** is checked, if you change either the Height or Width, the other value changes to maintain this ratio. If this is unchecked and you resize the image, it may become distorted.
 - Click **Reset Original Aspect Ratio of** to reset the image’s original aspect ratio and remove any distortion caused by resizing.

- 5 Specify the **Location** of the selected image.
- Position the selected image precisely by specifying its **X** and **Y Coordinates**.

- Specify the image's **Height Above Ground**.

Pictures

A variety of picture file types can be imported into and exported out of Home Designer Essentials.

Metafiles are also types of picture files that can be imported and exported. See “Metafiles” on page 376.

Exporting Pictures



Using the **Export Picture** tool is similar to creating a screen capture of everything in the current Home Designer Essentials view window. Pictures can be saved in various file formats and used in other applications.

Export Picture  is best suited for 3D views. When exporting a line-based view, best results can be achieved by saving it as a Metafile. See “To export a metafile” on page 376.

To export a picture

1. Open the view that you would like to export as a picture file.
2. Zoom, pan or otherwise adjust the view so that what you see on screen suits your needs. See “Displaying 3D Views” on page 323.
3. Select **File> Export> Picture (BMP, JPG, PNG)**  in any view to open the

Export Picture File dialog. See “Exporting Files” on page 34.



The **Copy Region as Picture**  tool also lets you create a picture file based on the current view, but allows you to specify what portion of the view is exported. See “Copy Region as Picture” on page 378.

Importing Pictures



Pictures can be imported into and displayed in floor plan view. Pictures do not display in camera views or overviews. See “Displaying Pictures and Metafiles” on page 377.

There are several ways to import a Picture into Home Designer Essentials:

- Select **File> Import> Picture (BMP, JPG, PNG)**  to open the **Import Picture File** dialog, which is a typical open file dialog. See “Importing Files” on page 38.
- Click and drag an image file from a Windows Explorer window into the Home Designer Essentials window.
- In any application, copy an image to the Windows Clipboard, then select **Edit> Paste> Paste**  from the Home Designer Essentials menu in an eligible view window. See “Paste Special” on page 68.

Note: Importing large, or multiple, Pictures into a plan file can result in program slowness.

An imported picture is placed in the center of the current view. Once imported, pictures can be selected and edited. See “Editing Pictures and Metafiles” on page 378.

Picture File Box Specification Dialog



Select an imported picture file and click the **Open Object** edit button to open the **Picture File Box Specification** dialog.

The settings in this dialog are similar to those on the **Line Style** tab in numerous other dialogs, with one exception.

Uncheck the **Show Outline** box to turn off the display of the picture’s border polyline.

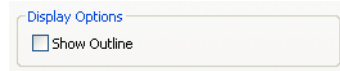

See “Line Style Tab” on page 225.

Metafiles

A metafile (**.emf**, **.wmf**) is a special picture file format made up of vectors (lines) that allow the image to be rescaled without loss of quality.

High resolution pictures of line-based views can be exported as a metafile.

Exporting Metafiles



An enhanced metafile (**.emf**) can be exported from floor plan view.

Only objects that display on screen are included in an exported metafile.

To export a metafile

1. Accurately position the view on screen.
2. Select **File> Export> Metafile**

(EMF) 

3. Drag a marquee  from corner to corner, defining the area that will included in the metafile.
4. Release the mouse to open the **Metafile Size** dialog.

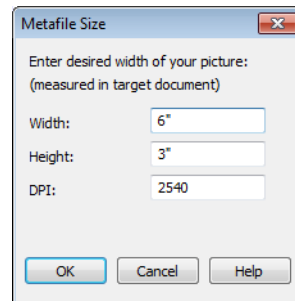

5. Specify the desired **Width** or **Height** of the metafile. When one value is edited, the other changes to maintain its aspect ratio.

Specify, too, the desired **Dots Per Inch (DPI)** for the metafile. A larger value results in a higher quality metafile, but also a larger file size.

6. Click OK to open the **Export Metafile** dialog, which is a typical Save As dialog. See “Saving, Exporting, and Backing Up Files” on page 33.
7. Enter a name and location on your computer for the metafile, then click **Save**.

Importing Metafiles



Metafiles can be imported into and displayed in floor plan view. Metafiles do not display in camera views or overviews. See “Displaying Pictures and Metafiles” on page 377.

There are two ways to import a metafile into Home Designer Essentials:

- Select **File> Import> Metafile (EMF,WMF)**  to open the **Import Metafile** dialog, which is a typical open file dialog. See “Importing Files” on page 38.
- You can also click and drag a metafile file from a Windows Explorer window into the Home Designer Essentials window to import it.

An imported metafile is placed in the center of the current view. Once imported, metafiles can be selected and edited. See “Editing Pictures and Metafiles” on page 378.

Metafile Box Specification Dialog



Select an imported metafile and click the **Open Object** edit button to open the **Metafile Box Specification** dialog.

The settings in this dialog are similar to those on the Line Style tab in numerous other dialogs, with one exception.

Uncheck the **Show Outline** box to turn off the display of the picture’s border polyline.

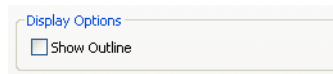

See “Line Style Tab” on page 225.

Displaying Pictures and Metafiles



The display of pictures and metafiles is controlled in the **Display Options** dialog. See “Displaying Objects” on page 59.

Pictures and metafiles are placed on the “CAD, Default” layer.

Pictures and metafiles can be imported into and displayed in floor plan view. A picture or metafile can only be seen in the view where

it was imported and cannot be imported into a camera view or overview.

Drawing Groups

Imported pictures are placed in the Back Drawing Group, and imported metafiles are placed in the Default Drawing Group. See “Drawing Groups” on page 87.

Editing Pictures and Metafiles

Pictures and metafiles can be selected and edited using the edit handles, the edit toolbar, and their specification dialogs.

Using the Mouse

Pictures and metafiles can be edited like CAD boxes. See “Editing Box-Based Objects” on page 82.

In the Specification Dialog

Pictures and metafiles can be customized in their specification dialog. See:

- “Picture File Box Specification Dialog” on page 376
- “Metafile Box Specification Dialog” on page 377

Using the Edit Handles

A selected picture or metafile can be resized, moved, and rotated using the its edit handles.

See “Editing Box-Based Objects” on page 82.

Using Dimensions

Pictures and metafiles can be relocated relative to other objects with precision using dimensions.

To avoid changing the selected object’s aspect ratio, make sure you choose to move the entire object rather than the selected edge. See “Moving Objects Using Dimensions” on page 350.

Using the Edit Tools



A selected picture or metafile can be edited in a variety of ways using the buttons on the edit toolbar. See “The Edit Toolbar” on page 21.

Copy Region as Picture



You can copy any portion of the screen and save it as a picture file using the **Copy Region as Picture** tool. See “Exporting Pictures” on page 375.

To use Copy Region as Picture

1. Open the view that you would like to copy all or part of as a picture.
2. Select **Edit > Copy Region as Picture** . Your pointer displays a marquee  icon.
3. Click and drag a rectangular selection marquee around the desired region.
4. The selection is copied to the Windows clipboard.
 - If the current view is vector-based, the **Metafile Size** dialog displays because metafiles are better suited for line-based pictures. See “Metafiles” on page 376.
 - If the current view is a 3D view, the region is sent directly to the Windows clipboard.

- From there, the picture can be pasted into another view or another program.

Walkthroughs



A 3D Walkthrough is a series of pictures saved as an **.avi** file that can be played like a video by other applications such as Windows Media Player.

To record a walkthrough

- Create a camera view. This view is the first frame of the walkthrough.
- From the view, select **3D> Walkthroughs> Record Walkthrough** .
- Specify a location and name for the walkthrough in the **Save Video As** dialog and click **Save**.
- In the **Walkthrough Options** dialog:

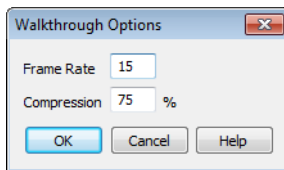

- Select a **Frame Rate** between 1 and 100. The value entered is the number of frames per second.
 - Select a **Compression Percent** between 0 and 100. A value of 0 gives the highest quality images and the largest file size.
 - Click **OK**.
- Use the camera movement tools to create additional views. Each time the screen redraws, that view is recorded as

the next frame in sequence. See “Editing 3D Views” on page 328.

- To move the camera without saving a view, select **3D> Walkthroughs> Pause Recording** to temporarily stop recording.
 - You can then select **3D> Walkthroughs> Save Frame** button to control what views are saved.
 - You can start recording again by selecting **Pause Recording** once more.
- When the walkthrough sequence is complete, select **3D> Walkthroughs> Stop Recording**  or close the view.

Note: Zooming in and out and using the scroll bars does not change the viewpoint and does not produce a frame for the walkthrough.

If you resize the current view window while recording a walkthrough, the program will stop recording.

To play a walkthrough

- Select **3D> Walkthroughs> Play Walkthrough**  to open the **Select Video File** dialog.
- Browse to an **.avi** file on saved on your computer. Your default video application plays the walkthrough video.

Printing

Home Designer Essentials provides a variety of printing options, from printing plan and 3D views to a set of templates that can be assembled into a 3D model.

Home Designer Essentials also allows you to save your drawings in pdf file format that can then be sent to a printing service.



Screen captures are provided for illustrative purposes only and are not an endorsement of any products.

Chapter Contents

- Introduction to Printing
- The Printing Tools
- Display Options and Printing
- Printing Directly from a View
- Printing to Scale
- Printing Across Multiple Pages
- Printing to a PDF File
- Page Setup Dialog
- Print Dialog
- Print Image Dialog
- Print Model

Introduction to Printing

Home Designer Essentials offers printing options to suit a variety of needs. You will benefit from understanding the output options clearly and choosing the one that makes the most sense for the project at hand.

Output Options

Printing a View - You can print any view of your plan. Home Designer Essentials can print to almost any printer that supports printing graphics from Windows programs. See “The Printing Tools” on page 382.

Printing to a Remote Printer - Plans can be printed to a .pdf file and printed remotely. See “Printing to a PDF File” on page 385.

Print Model - If your final printed output will be used to create a 3D model of your design, the Print Model feature works best. See “Print Model” on page 388.

Terminology

There are a couple of terms that you should familiarize yourself with.

Paper Size - The dimensions of the paper to be printed on. Specifying a paper size that is smaller than the scaled drawing allows large drawings to be printed across multiple pages.

Printing Scale - Drawings are often printed to scale for accuracy. $\frac{1}{4}'' = 1'$ and $1\text{ m} = 50\text{ m}$ are examples of common scales. Home Designer Essentials prints to a scale of $1/16'' = 1'$ by default, although this scale can be changed in the **Page Setup** dialog. See “Page Setup Dialog” on page 386.

When a particular scale is not important, drawings can also be sized to fill a particular area. See “Printing to Scale” on page 383.

Printing Problems

Home Designer Essentials can print to almost any printer that supports printing graphics from Windows programs. If you encounter difficulties when trying to print, see “Troubleshooting Common Technical Issues” on page 403.

Printer Drivers

Printer drivers are programs that interpret between software programs and the printer. The drivers are usually created by the manufacturer of the printer and are typically updated regularly. Different drivers are used for different versions of Windows.

It is useful to keep track of the drivers for each printer you use and update them whenever the Windows operating system is updated or replaced.

Note: You should only update your printer driver if you are having problems printing.

To find the version of your printer driver, select **Start > Control Panel > Printers and Faxes** to view the Printers information for Windows. Select the printer in question, then choose **File > Properties**.

In most **Printer Properties** dialogs is an **About** button which you can click to find the version and creation date of the driver currently in use. If you experience printing problems and yours is not the latest driver,

consider replacing it with an updated driver. Visit your printer manufacturer's Web site for more information.

Windows provides information about installing printer drivers. To access Windows Help, select **Start> Help**. If you have problems installing a driver, refer to your printer documentation for technical support.



Options available with one driver may not be available with another. Printers supported in one version of Windows may not be supported by the manufacturer in another.

Clearing Printer Information

Some information specific to individual printers, such as available paper sizes, is saved with each plan file. You can select **File> Print> Clear Printer Info** to clear the printer-specific information stored with the plan file.

The Printing Tools



Select **File> Print** to view the Print Tools submenu.



Page Setup - Opens the **Page Setup** dialog, where printing options are set. See "Page Setup Dialog" on page 386.



Scale to Fit - Automatically selects a scale that fits your plan to the printer page. See "Printing to Scale" on page 383.



Center Sheet - Automatically centers your drawing on the sheet. See "Center Sheet" on page 383.



Print Preview - Shows how the current view will appear when printed. See "Print Preview" on page 383.



Print - Prints the current floor plan. See "Print Dialog" on page 387.



Print Image - Prints a screen view including images, textures and backdrops. See "Print Image Dialog" on page 388.



Print Model - Opens the **Print Model** dialog, allowing you to print templates for making a physical model of your plan. See "Print Model" on page 388.

Clear Printer Info - Clears the printer information associated with the current page setup.

Display Options and Printing

The display of objects in views can be used to affect the printed output. Some display options allow you to preview the printed output on screen before any paper is used.

Objects must be visible in order for them to print; but not all items that are visible print.

- Camera symbols in floor plan view, for example, do not print.

- The Reference Display does print if it is visible. See “Reference Display” on page 177.



To see how your printed output will appear on paper, select **File> Print> Print Preview**.

Displaying Objects



You can control the display of objects when printing directly from a view in the **Display Options** dialog. See “Display Options Dialog” on page 60.

Print Preview



Select **File> Print> Print Preview** for an on-screen representation of how the current view will appear when printed. Print Preview is only available in floor plan view. See “Printing to Scale” on page 383.

The printer page displays as a solid white rectangle, and blue lines along the edges of the printer page indicate the edges of the printable area, as defined by the currently selected printer. See “Page Setup Dialog” on page 386.

Objects such as camera symbols that do not print do not display in **Print Preview** . Text and dimension objects appear on-screen as they will on the printed page.

Center Sheet





Select **File> Print> Center Sheet** to center the printer page on the drawing. This moves the printer page relative to the drawing but does not affect the coordinates of objects in the drawing. The location of the printer page is independent for each floor of the model.

Printing Directly from a View



To print directly from any floor plan view, choose **File> Print> Print**. See “Print Dialog” on page 387.

To set up print formatting before printing, select **File> Print> Page Setup** . See “Page Setup Dialog” on page 386.

3D views can be printed using **File> Print> Print Image** . See “Print Image Dialog” on page 388.

Printing to Scale

Several different print scaling options are available. The type of view that you are printing determines which options you may choose from.

Orthogonal Views

Floor plan views are orthogonal views, which means:

- Your line of sight is at a right angle to all objects in the view.

- Objects do not appear to decrease in size as their distances from the viewer increase.

Orthogonal views can be printed to scale.

The scale set in the **Page Setup** dialog is inherited by the **Print** dialog. This scale can be overridden on an individual basis in the **Print** dialog. See “Print Dialog” on page 387.

Select **File> Print> Scale to Fit**  in an orthogonal view to select a suitable scale and re-center the printer page so that everything fits on the page.

Imperial drawing scales are typically noted in inches per foot. Larger scales, such as 1

inch = 50 feet or 1:200m, are often used for property layouts.

Perspective Views

Camera views and overviews display the model much the way the eye would see it and cannot be scaled.

- Objects in the view may be at any angle relative to your line of sight.
- Objects seem to decrease in size as their distances from the viewer increase.

Perspective views can only be printed using the **Print Image**  tool. See “Print Image Dialog” on page 388.

Printing Across Multiple Pages



When printing directly from a floor plan view it is possible to print at a scale that does not fit the drawing on one page.

To see on-screen what the drawing will look like when printed, select **File> Print> Print**

Preview  and then **Window> Fill**

Window . Grey lines across the drawing sheet indicate where the page breaks will occur. See “Print Preview” on page 383.

To print across multiple pages

1. Select **File> Print> Print Preview**  to display the white rectangle representing the printer paper. See “Print Preview” on page 383.
2. Click the **Select Objects**  button, then click near an edge of the printer paper rectangle to select it.

When selected, the printer paper is highlighted in pale grey and a square Move edit handle displays at its center.

3. Click and drag the Move edit handle to position the printer paper so that the portion of your drawing that you would like to print on your first page is located within the printable area of the page.
4. Select **File> Print> Print** . In the **Print** dialog, make sure **To Scale** is selected, then click OK. See “Print Dialog” on page 387.
5. Select the printer paper rectangle and move it so that the desired contents of your second printed page are within the printable area and print **To Scale**.
6. Continue moving the printer paper and printing as needed.

When printing multiple pages, it is generally a good idea to leave some overlap on the edges of each page to make sure that

information near those edges is not left off the printed pages by mistake.

Printing to a PDF File

Portable Document Format, or **.pdf** files, are one of the most universally compatible and efficient file formats and can be viewed and printed on most computer platforms.

Creating a **.pdf** document requires that a **.pdf** printer driver be installed on your computer. This is not a physical print device, but a software program that is recognized as a printer by all other programs and creates a **.pdf** file that can be read and printed using Adobe® Reader®.

When you print to a **.pdf** print driver, you will be asked for a file name and destination automatically.

To print to .pdf

1. Select your **.pdf** printer driver as you would select any other printer in the **Page Setup** dialog. See “Page Setup Dialog” on page 386.
2. Select **File > Print > Print**  to open the **Print** dialog. Your **.pdf** printer driver will be listed as the selected printer.
3. Select the needed options in the **Print** dialog, then click **OK**.
4. In the **Save As** dialog, select a **File name** and **Save in** location for your **.pdf** file. For information about the settings in the **Save As** dialog, see “Saving, Exporting, and Backing Up Files” on page 33.

Page Setup Dialog

 Select **File > Print > Page Setup** to open the **Page Setup** dialog.

The **Page Setup** dialog is only available when an orthogonal view is active. When a

perspective view is active, **Page Setup**  is not available.

The settings in this dialog, including the selected printer, are specific to the current orthogonal view file, and are saved with the **.plan** file.

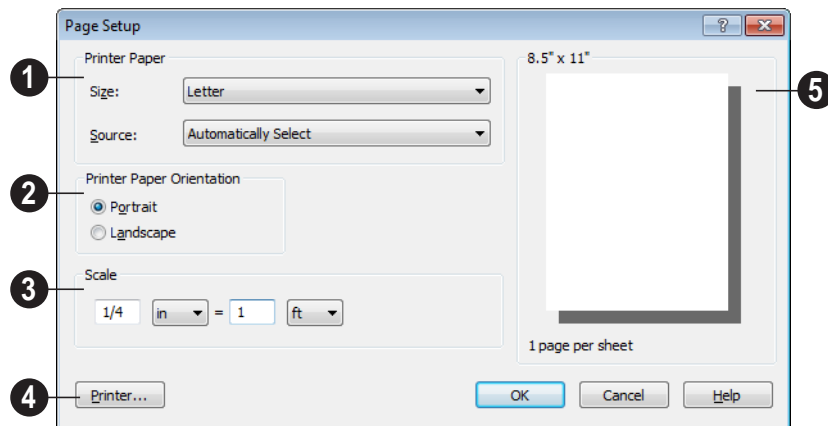

1 Specify the printer paper **Size** and **Source**. The options available in these drop-down lists are controlled by the currently selected printer's driver. See "Printer Drivers" on page 381.

2 Select **Portrait** or **Landscape** paper orientation.

3 Specify a print **Scale**. 1/16 inch = 1 ft (1m = 50 mm) is the default.

4 Click the **Printer** button to select a printer.

5 A preview of the printer paper displays on the right side of the dialog.

Click **OK** to close the dialog and apply any changes.

Clearing Printer Information

Select **File > Print > Clear Printer Info** to clear the printer-specific information stored in the **Page Setup** dialog.

Print Dialog



To print directly from floor plan view and the Materials List, select **File> Print> Print**. The **Print** dialog opens.

Note: 3D views can be printed using Print Image. See “Print Image Dialog” on page 388.

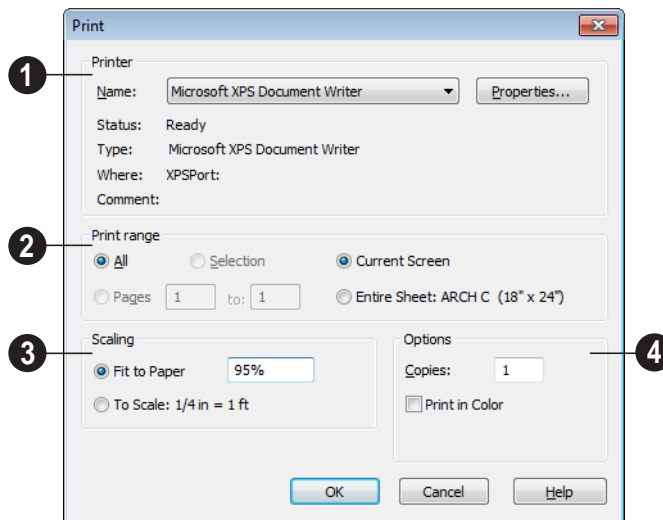

1 Specify **Printer** parameters.

- Choose a printer from the **Name** drop-down list.
- Click **Properties** to verify that the printer’s paper size, orientation and other settings are configured correctly.

2 Specify the **Print Range**.

- **Current Screen** prints only the portion of the entire View showing on screen.
- **Entire Sheet** prints the entire sheet even though you may be zoomed in on a portion of the view.

Note: If you are zoomed out, and Current Screen is selected, any white space around the plan is calculated for printing.

3 Select from the available **Scaling** options.

- **Fit to Paper** prints the plan on one page. The program will use whatever scale is necessary to fit the plan on one page. If a percentage less than 100 is specified, only that portion of the printable area is used.
- Select **To Scale** to print at the scale specified by settings in the current plan.

- 4 Select from the available **Options**.
- Specify the number of **Copies** to print.
 - Check the **Print in Color** box to print in color or clear the check box to print in grey scale.

Most black and white printers will print a grey scale approximation of the colors if **Print in Color** is selected.

Print Image Dialog

 Any view can be printed by selecting **File > Print Image**. This is the only way to print 3D views. See “3D Rendering” on page 336.

The **Print Image** dialog is similar to the **Print** dialog; however, the printing process is different. **Print Image** prints individual pixels as opposed to vectors (lines).

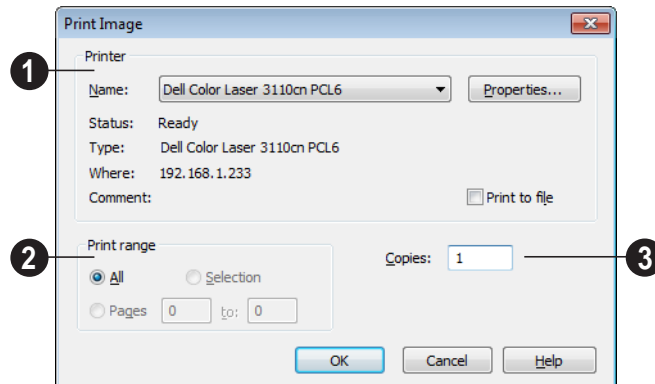

- 1 Specify the **Printer** parameters.
 - 2 Specify the **Print Range**.
 - 3 Specify the number of **Copies**.
- Choose a printer from the **Name** drop-down list.
 - Click **Properties** to verify that the printer’s paper size, orientation and other settings are configured correctly.

Print Model

 The Model Maker allows you to create a template of your plan that can be

printed to scale and assembled into an actual 3D model. Three groups of templates are

used in the process. Walls and roofs are printed separately. These can then be placed onto a floor plan view, which is printed as a layout for the entire model.

Since different people build house models in different ways, the Model Maker focuses on providing the most necessary tools. It may not necessarily give you everything you might want in order to build house models your way. For example, you may want to affix tabs to certain wall or roof edges to help attach them to their neighbors. While you can draw some of these things onto printed sheets, the system does not provide them

automatically. What it does provide is accurate templates for wall and roof sections. Combining these with your own skills helps you create professional quality models.

Printing the Model

The best way to understand how the various options affect the final product is to make a very simple two story plan and try them out.

To print the model templates, choose **File> Print> Print Model** . The **Print Model** dialog opens.

Print Model Dialog

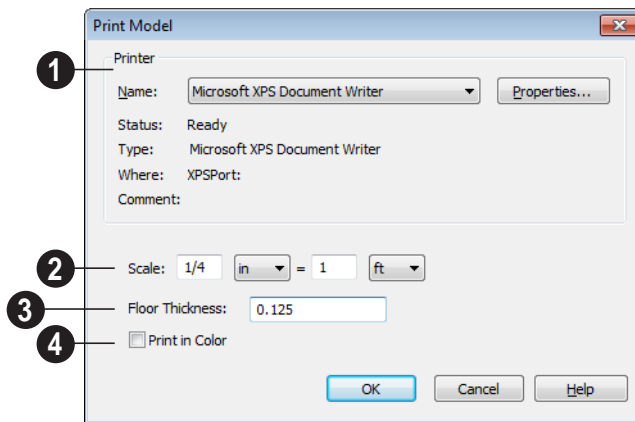

- 1 Select a **Printer** from the drop-down list and set its **Properties**.
- Landscape is usually the best mode for printing models. If it is not your default printing mode, it can be selected via the **Properties** button.
- Information about your printer and its current setup displays here.

- 2 Specify the **Scale** for your model. The default is 1/16 inch = 1 foot (1 m = 50 m).
- 3 Specify the **Floor Thickness**, which is the thickness of the material that you will use for the floor platform of the model.
- 4 Check **Print in Color** to print in color rather than black and white.

Assembling the Model

Once the templates have been printed, they are ready to be assembled. You need scissors and an adhesive and a rigid material that can be easily cut and glued, such as thin cardboard or styrofoam, to provide support for the 3D model.

Floor Plan View Template

Begin by laying out the floor plan view, which is used as a layout for the entire 3D model. If your floor plan view template printed on a number of sheets, they should be combined into one. Exterior and interior wall surfaces should match throughout.

Adhere your complete floor plan view template to a sturdy and dedicated surface to provide support for your walls.

Walls

Walls should be cut and fixed to a rigid backing so that they can stand on their own and support the weight of the roof or floors above them. How they are cut and assembled varies depending on the desired final

appearance of the model and how they were printed.

It may be helpful to take the thickness of the rigid material being used into consideration and override the scale thickness of the walls so that it agrees with your material thickness.

If your walls were resized in the **Print Model** dialog, you may see unwanted lines between floors that should merge together seamlessly. This is usually due to walls whose exterior surfaces match but overall thickness does not. You can prevent this by checking **Use Scale Wall Thickness**, which prevents walls from resizing. This is best if you do not want to print the interior wall surfaces, or are using a modeling material that closely matches the scale thickness of your walls.

Roofs

Roof planes are joined together when possible before printing. For each roof surface, the fascia and soffit surfaces are attached at the eave, so that the least amount of taping produces the roof and adjoining surfaces.

Materials Lists

Materials Lists can be created, edited, and printed directly from the program. They can also be exported as text files for use in other programs.



The Materials List is based on certain assumptions that may not match your building style. Home Designer Essentials makes no representation as to the accuracy or reliability of the Materials List generated by Home Designer Essentials. Always compare the Materials List with a manual take-off before providing a quote or ordering materials for a job.

Chapter Contents

- The Materials List
- Creating an Accurate Materials List
- Organizing Materials Lists
- Materials List Display Options Dialog
- Editing Materials Lists
- Exporting the Materials List
- Conditioned Area Totals

The Materials List

A Materials List is like a snapshot of the current plan at the time that the list is made. Any changes made to the model after a Materials List is generated are not included in that list. Create a new Materials List if you would like it to include these changes.

It is not necessary to wait until the plan is complete to generate a Materials List. In fact, you can create a series of Materials Lists reflecting costs at various stages of a project.



For comparison, generate Materials Lists with and without a proposed plan modification.



Select **Tools > Materials List > Calculate From All Floors** to generate a Materials List for the entire model.

Materials lists can be lengthy, and only a portion of the list may display on your screen at one time. Use the scroll bars to scroll through the complete list. Move the pointer to cells in the list and click to make changes.

A Materials List is like a snapshot of the current plan at the time that the list is made. Any changes made to the model after a Materials List is generated are not included in that list. Create a new Materials List if you would like it to include these changes.

It is not necessary to wait until the plan is complete to generate a Materials List. In fact, you can create a series of Materials Lists reflecting costs at various stages of a project.



For comparison, generate Materials Lists with and without a proposed plan modification.

Creating an Accurate Materials List

In order to take full advantage of Home Designer Essentials's Materials List capabilities, bear in mind that using generic objects like geometric shapes from the

library to represent objects that aren't available in Home Designer Essentials can result in items being calculated in the Materials List in a manner that you might not expect.

Organizing Materials Lists

You can control what items are calculated in the Materials List by specifying which categories are used.

There are some parts of a model that cannot be excluded from the Materials List. Floor and ceiling platforms are prime examples. If

you need to generate a Materials List for only part of a plan, such as an addition, consider making a copy of the plan file. In the copy, delete the as-built portion of the plan and then generate a Materials List.

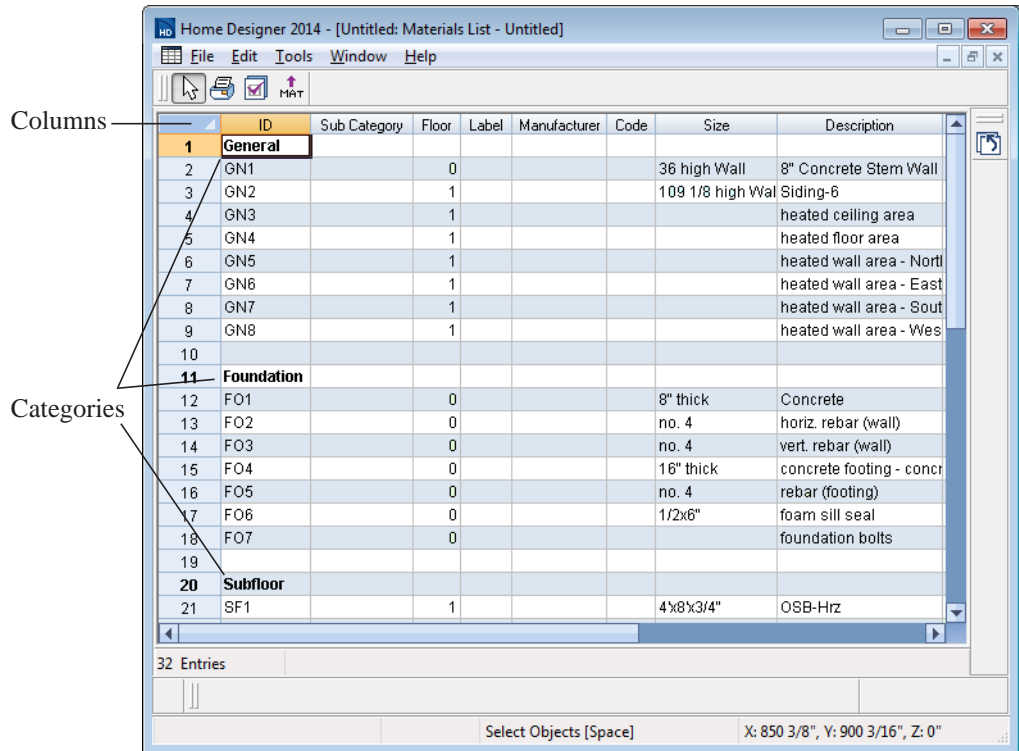

Categories

The line items in the Materials List are organized into a set of predefined categories, such as Electrical and Framing, which display in the **ID** column.

To specify a line item's category

1. Create a Materials List.

2. Click in the cell in the ID column for a line item.
3. Select the desired category from the drop-down list that becomes available.

The categories that are available cannot be altered; however, you can specify which categories are included for individual lists in the **Materials List Display Options** dialog.

Materials List Display Options Dialog



When a Materials List is open, select **Tools> Display Options** to open the

Materials List Display Options dialog for the currently open list.

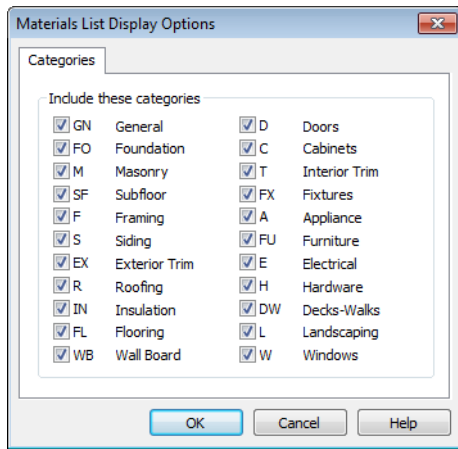

Check the box beside the name of each category that you want to include in the active Materials List.

These categories appear in the ID column in the order they are presented here.

The Materials List changes automatically to reflect any changes you make as soon as the **OK** button is clicked.

Note: The information in a suppressed category is still part of the Materials List. If the Materials List is exported, suppressed categories are exported, as well.

Editing Materials Lists

Materials lists can be edited in a variety of ways. You can adjust the width of a column by clicking and dragging the bar on the right side of the column name.

Adding Information

You can enter information in the Price and Comment columns for each item.

Adding price or other information for any item is straightforward. Simply click in the cell and type the desired information.

Changing Information

You can change the information in any column in an individual Materials List. As with added information, click in a cell to select the existing text, then type in the desired text.

To move an item in a Materials List to a new category, select the cell in the **ID** column and choose a new category from the drop-down list that becomes available. See “Categories” on page 394.

Total Cost

Total Cost is calculated using the Count, Unit, Price, %Markup, Labor and Equipment columns to calculate the cost. The formula used is:

$$(\text{Count} + \text{Extra}) * \text{Price} * (1 + (\% \text{Markup}/100)) + ((\text{Count} + \text{Extra}) * \text{Labor}) + ((\text{Count} + \text{Extra}) * \text{Equipment})$$

If a column does not appear, 0 is used for the value of that column with the exception of

Count and Price, which are always used in the calculation even if they are not shown.

Copying Information

Portions of a Materials List can be copied and then pasted into a **Text**  object or into a word processing program or spreadsheet program using the standard Windows Copy (Ctrl + C), Cut (Ctrl + X), and Paste (Ctrl + V) commands. See “Copying & Pasting Text” on page 361.

Exporting the Materials List



Any Materials List can be exported into a text (.txt) file that can be opened directly by most spreadsheet programs. In a Materials List window, select **File> Export Materials List**.

The **Write Materials Export File** dialog will open. This is a typical File Save dialog. See “Exporting Files” on page 34.

Estimating Software

You can export a Materials List to a word processor or spreadsheet program to arrange it in your estimating format. You can also export the Materials List to a number of

commercial estimating programs in whose databases you can keep your current pricing and generate reports based on this data.

Before purchasing an estimating software program, be sure that the program supports the direct import of Home Designer Essentials Materials Lists.

Any questions regarding estimating software packages and how they interact with Home Designer Essentials should be directed toward the company providing the estimating software. Home Designer Essentials is unable to provide any technical support for third party programs.

Conditioned Area Totals

The Materials List calculates the total areas of walls, floors, ceilings, doors and windows that separate the conditioned space in a plan from unconditioned space. This information is listed in the General category of the

Materials List. See “Categories” on page 394.

Conditioned area totals can be entered into third party programs such as **REScheck** to determine whether the plan meets the energy code in use in your area.

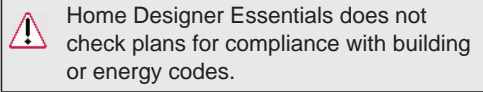

Walls, doors and windows are categorized as north, south, east, or west facing for the purposes of conditioned area totals.

If a wall is oriented at 45° or less to north in a plan, it will be categorized as a “North” wall. Any doors and windows in this wall will also be categorized as “North”.

Similarly, south-facing walls, doors and windows are categorized as “South” if they are oriented at 45° or less of south in the plan.

Walls, doors and windows oriented within 45° of either east or west will be classified as “East” or “West”, respectively.

The orientation of a curved wall is based on the direction of its chord.

Doors are always categorized as doors rather than as glass (windows). This is the case even when a door is specified as a Glass Door or when it is part of a mulled unit.

Additional Resources

Home Designer Essentials offers a variety of resources to help you become familiar with the many features it offers.

- Reference Manual
- User's Guide
- Home Designer Web Site
- Home Talk Online User Forum
- Technical Support

Reference Manual

The Home Designer Essentials Reference Manual is a comprehensive source of information for Home Designer Essentials 2014. Chapters are organized by subject, beginning with the fundamental concepts and progressing to the more advanced features.

The Reference Manual is presented in .pdf file format and includes a Table of Contents and Index. This manual is available online by selecting **Help> View Reference Manual**

 from the program menu.

User's Guide

Written for new Home Designer Essentials users, but a helpful reference for users of all experience levels as well, the User's Guide features a series of tutorials designed to introduce the basics of using the program.

The Home Designer Essentials User's Guide is organized by topic and walks you through

the process of creating a complete model, from the first wall to the interior design and landscaping.

This guide is available online by selecting **Help> View User's Guide** from the program menu.

Online Help Videos

Another resource designed to illustrate Home Designer Essentials's powerful tools is the set of tutorial videos available on our web site.

To view the online videos, select **Help> View Online Help Videos** from the program menu or visit video.homedesigner.chiefarchitect.com/videos.

Home Designer Web Site

If you have questions that the online Help feature has not answered, feel free to turn to the our web site.

A database of common technical support questions and answers related to Home

Designer Essentials is available through a searchable interface.

Select **Help> Visit Home Designer Web Site**  from the menu to launch your default internet browser to www.HomeDesignerSoftware.com.

Home Talk Online User Forum

The Home Talk Bulletin Board offers several ongoing discussions about a variety of topics related to the use of Home Designer Essentials. It's rich with useful tips and available free of charge to all registered Home Designer Essentials users.

- Discussions are initiated and carried out by users.

- Experienced users share knowledge with each other and beginners.
- Home Designer Essentials Staff members post announcements, advice and technical information.

To visit the Home Talk forum, select **Help> Home Talk** or go to: HomeTalk.HomeDesignerSoftware.com.

Technical Support

Chief Architect takes pride in offering world class technical support services that can be accessed by telephone or on our web site. Select **Help> Technical Support** from the program menu to visit: www.HomeDesignerSoftware.com.

Before contacting Technical Support, take a moment to see if the answer to your question is found in the Help resources, tutorial videos, or in our on-line Help Database at www.HomeDesignerSoftware.com.

When you contact us, Technical Support will refer you to these resources if the answer can be found there.

So that our Technical Support specialists can assist you as efficiently as possible, please

refer to “Technical Support Services” on page 402 for additional trouble-shooting suggestions and information that will be needed before placing your call.

Upgrade to Chief Architect

Chief Architect is a premium, professional residential drafting and 3D design program that allows builders, architects and other professionals in the building and interior design trades to produce construction documents and high quality 3D renderings of their plans.

Chief Architect can open and edit plans created in Home Designer Essentials. In

addition, Home Designer Essentials can open plans created in Chief Architect for viewing, as well.

To learn more, select **Help > Upgrade to Chief Architect**. to launch your default web browser to www.chiefarchitect.com.

Technical Support Services

Chief Architect is committed to providing world-class technical support to complement our products.

The primary function of technical support is to make sure our software is functioning

correctly and to help you quickly resolve problems that prevent its normal use. Our technical support professionals are eager to work with you to make certain our software is functioning as designed.

Reference and Training Resources

Chief Architect offers a variety of reference options in addition to the resources that come standard with the program.

Help Database

The Home Designer online Help Database contains a variety of articles describing how to resolve common technical problems and achieve specific design goals.

The Help Database is found in the Technical Support section of the Web site and can be referred to again and again at your

convenience at www.HomeDesignerSoftware.com.

Online Help Videos

Chief Architect has developed a collection of training videos that contain in-depth training on a wide range of topics. These videos are available on our Web site, www.HomeDesignerSoftware.com.

User Forum

Our Home Talk User Forum is a great place to discuss and exchange ideas with other

Home Designer Essentials users. Here you can post questions, read discussions from other users, and post suggestions to improve our product. In addition to our regular users, from time to time our support and

engineering teams monitor the forum and provide input and discussion on current topics. This resource is available free of charge at HomeTalk.HomeDesignerSoftware.com.

Troubleshooting Common Technical Issues

Chief Architect strives to make certain our software works correctly; however, from time to time issues arise that prevent its normal operation.

Installation Issues

The following are common reasons for installation failure of Home Designer Essentials and other software:

- Anti-virus software is enabled and interfering with installation. Anti-virus software is the most common cause of installation failures for any type of software. Refer to your anti-virus software's documentation for details on how to disable the software and re-enable it once installation is complete.
- The recommended minimum system requirements are not met. See "System Requirements" on page 7.
- The computer has a CD drive but not a DVD drive. A standard CD drive will not read DVD discs.

- The DVD has fingerprints, scratches, or other defects. Sometimes a small fingerprint can prevent the program from installing. Clean the disk with soft cotton cloth. Be sure to use soft cotton rather than paper products on disks to avoid scratching.



If you see visible cracking on a CD or DVD, do not insert it in your CD/DVD drive. Cracked disks can fly apart and cause damage to your drive.

- You do not have sufficient rights to install the software. Verify that you have administrative rights and the administrative password during the installation process. If you are on a corporate network, consult your network administrator for assistance.

Refer to the on-line **Help Database** for solutions to common installation problems. If the answer to your question is not found there, contact our Technical Support department for assistance.

Troubleshooting Printing Problems

Printing problems fall into two main categories: those that prevent the printer from working in any program and problems

printing from Home Designer Essentials. To determine if the problem is specific to Home Designer Essentials, try the following:

1. Begin by clicking on the Windows **Start** button, and select **Printers**.
2. Right-click the printer that is not functioning properly in the **Printers** folder.
3. Click **Properties** from the menu that appears.
4. On the **General** tab, click the **Print Test Page** button.

If the printer does not produce a test page, the problem is not one that Chief Architect Technical Support can solve. Follow these suggestions:

- Check the connection between the computer and the printer.
- Check your printer documentation for troubleshooting printer problems.
- Contact your printer's manufacturer or check their Web site for support information.

Your printer manufacturer is the best resource for solving problems of this type. Chief Architect Technical Support is not able to help diagnose and solve problems that prevent printing from any program.

 It is a good idea to keep the Owner's Manual for your printer close at hand. Write inside the Owner's Manual the various phone numbers for technical support for that printer – for the original manufacturer and for your local dealer.

Printers vary widely in how they function. Sometimes a faulty cable can be a problem. Often, solving a printing problem is as simple as downloading and installing an updated printer driver. See “Printer Drivers” on page 381.

If you can print from Home Designer Essentials but are not satisfied with the output, refer to “Printing” on page 380 for information on how to set up and use the printing functions in the program. Legacy users should bear in mind that each release has new features and enhancements, so techniques that were used in prior versions may not work in the current version.

Make sure that you use **Print Preview**  before printing. Print Preview displays the printed paper, or drawing sheet, as a white rectangle on screen, and shows how the sheet is scaled and positioned relative to your drawing. If the drawing is not on the drawing sheet on-screen, it will not be on the sheet when you print. See “Print Preview” on page 383.

Make sure that your scaling is correct for the paper size. If the plan is much smaller or much larger than the drawing sheet, you may need to change your Scale. See “Printing to Scale” on page 383.

64 Bit Versions of Windows

Some printers may not function correctly on 64 bit Windows operating systems. If you are experiencing a printing problem while using a 64 bit version of Windows, please contact the printer's manufacturer to verify that you have the correct driver installed.

Printing to a legacy parallel printer port on a Windows 64 bit machine may not work correctly when using a hardware lock. USB printers should not be affected.

Clearing Printer Information

Some information specific to individual printers, such as available printer paper sizes, is saved with each plan file.

If you are encountering problems when printing, or unexpected options in the **Page Setup** dialog, select **File> Print> Clear Printer Info** to clear the printer-specific information stored with the plan file.

After using **Clear Printer Info**, select **File> Print> Page Setup** . Make sure the

settings in the **Page Setup** dialog are correct, and then click **OK** and **Save**  the file.

Help Database

For answers to frequently asked questions regarding printing and other topics, select **Help> Visit Home Designer Essentials**

Web Site  and browse the Technical Support section of our Web site, www.HomeDesignerSoftware.com. Our Technical Support specialists post new articles periodically to help resolve problems you may encounter.

Error Messages

Most common error messages have a known cause and simple resolution. When you encounter an error or warning message in Home Designer Essentials, you can click the **Check Help Database** button in the message box to launch your default internet browser to the Home Designer Help Database on our Web site,

www.HomeDesignerSoftware.com. If an article discussing the message is available it will display, providing information about the message and how best to avoid it.

It is important that abnormal errors be reported to Chief Architect Technical Support so that we can identify and resolve any problems.

The content of an error message is useful in diagnosing its cause. If you encounter an error message, read it carefully and write down the error number and the exact text of the error message.



Press the Print Screen key on your keyboard to capture a picture of the error message. Open a new word processing document or e-mail message and choose **Edit> Paste** to paste a copy of the error message into the document for later reference.

If you encounter the error more than once, make a note of your steps prior to receiving the message.

Before you report an error, check the Help Database to see if the error is already documented by typing the error message or part of the error message into the search form.

Finally, check to see if there are program updates available. These updates are provided free for the current version of Home Designer Essentials and contain enhancements and other changes that allow the program to perform at an optimum level. Select **Help> Download Program Updates**

from the Home Designer Essentials menu to visit our Web site, www.HomeDesignerSoftware.com, and follow the instructions.

Error Reporting

When an error occurs, you may have the option in the message box to send the report to Chief Architect.

No personal information is sent. When you click **Send**, your default internet browser launches and a Web page appears on screen. This message confirms that the report was sent successfully and may give you further instructions on how to proceed.

Contacting Technical Support

Before contacting Technical Support, take a moment to see if the answer to your question is found in the Reference Manual, Help index, or in our on-line Help Database. When you contact us, Technical Support will refer you to these resources if the answer can be found there.

Chief Architect's world-class technical support is available Monday through Friday from 6 AM to 5 PM Pacific Standard Time and can be reached at (208) 292-3375 or via our Web site, www.HomeDesignerSoftware.com.

There are several things you can do to ensure a speedy answer to your question when you contact Technical Support.

- Before contacting Technical Support, select **Help > About Home Designer Essentials** and make a note of the first characters of your Product Key and the exact version of Home Designer Essentials you are using. Technical support is available to the owners of software licenses. When you contact Technical Support, be prepared to verify that you are the owner of the software license.
- Before contacting Technical Support, check to see if there are program updates available for download. Our engineering team periodically creates updates to the program to resolve functionality or program issues that were unknown at the time of release. These updates are provided free of charge for the current released version and can be accessed by selecting **Help > Download Program Updates** from the menu.
- When you first encounter a problem or error message, copy the exact wording of the message or a detailed description of the problem. This helps us isolate the problem and provide you with a solution as quickly as possible.
- When placing a call to Technical Support, be at the computer or work station that is experiencing the problem and have Home Designer Essentials running. If you do not have access to the problem computer at the time of the call, the technician may be unable to reproduce the issue and/or suggest a remedy that can be implemented and verified immediately.

- Be prepared to reproduce the problem when you contact us. If the problem cannot be reproduced, there is a reduced chance that we will be able to resolve the problem on your first phone call.

Online Information

Home Designer Essentials has a variety of support resources available on our Web site. These include our **Technical Support Help Database**, the **How do I...? Solution Finder**, downloadable program updates, and ways to contact our Technical Support department. To access these resources, visit: www.HomeDesignerSoftware.com.

Our support team is happy to assist you in finding the best resource to answer your questions, and can resolve most issues in just a few minutes. In order to allow us to quickly answer your calls, we ask that you limit yourself to one question per support call.

Online Support

Questions can be answered online by the Technical Support department. To submit a technical inquiry online, visit the Technical Support section of our Web site and use the [Online Support Center](#).

This route ensures that your question is delivered to the first available support professional. Requesting assistance of an individual specialist is not recommended, since that person may not be available to answer your question in a timely manner.

Telephone Support

Our Technical Support team is committed to answering your questions as quickly as possible and in the order received. Your call is important to us; however, there are times when we get more calls than expected and you may have to wait a few minutes before speaking to a technician.

Index

Numerics

3D	
Delete Surface	324
3D Roof Designer	194
3D Views	
Display	323
Doll House	321–322
Editing	331
Framing Overview	322
Full Overview	321
Generation, Speed up	340
Overviews	320
Working in	331
3D Wall Designer	103

A

Adding	
to the Library	290
Adjust	
Material Definition	305
Align	
Curved Stairs Between Floors	90
Curved Walls Between Floors	111
Objects	89
Walls	110
Alphabets	
International	354
Unicode	354
Angle Snaps	64
Appearance Preferences	50
Appliances	
Built into cabinets	244
Outlets, where placed	232
Archive Files	36

Area	
Living Area calculation	125
of Rooms	126
Arrange	
All	317
Icons	317
Arrow	
Auto Positioning	363
Tab	364
Text Line With	362
Artwork	
Creating textures	306–307
Attic	
Floor	176
Rooms	124
Walls	112
Auto	
Archive	36
Place Outlets	125, 230
Save Files	36
Stairwell	215
Auto Rebuild	
Foundation	181
Terrain	262
Automatic	
Exterior Dimensions	346

B

Backdrops	337
Definition	337
Background Color	51
Backup	
Entire Plan	42
Files	35
Balusters	117

Definition	206
Base	
Cabinets	243
Basements	
Daylight	184
Bay Windows	155
Bay/Box Window	
Specification Dialog.....	169
Blend Colors with Materials	302
Blind Cabinets	250
Bonus	
Library Catalogs.....	287
Rooms.....	176
Bow Windows	156
Box	
Windows.....	156
Break	
Line	92
Line, partial.....	92
Terrain Breaks	260
Wall.....	102
Build	
Foundation.....	173, 179
House.....	367
New Floor	172
Roof Dialog.....	192
Terrain.....	262
Bumping/Pushing	88

C

Cabinet	
Defaults	242
Designer	242
Modules Library.....	244
Specification Dialog.....	251
Tools	243
Cabinets	
Angled front	249
Base.....	243
Blind	250
Built-in appliances	244
Corner	249

Delete face items.....	253
Door/drawer style	244
Doors, diagonal	254
Doors, glass	256
Editing	247
End cabinets	249
Fillers.....	245
Front Indicators	247
Front Tab	252
Full Height.....	243
General Defaults.....	243
Glass doors.....	256
Island.....	250
Minimum Width.....	243
Module Lines	247
Moving, with Wall.....	248
Normal	249
Outlet placement	232
Peninsula radius	249
Radius end.....	249
Resize Increment.....	243
Reverse Appliance.....	254
Shaped	249
Special shapes	249, 251
Wall	243

CAD

Angle Snaps.....	64
Move to Front of Group	87

Calculate

From All Floors	393
Materials on soffits.....	278

Camera

Change Settings	333
Create Views.....	321
Field of View	330
Move Tools.....	326
Move Up/Down One Floor	329
Orbit Tools	327
Specification Dialog	333
Tilt Tools	328
Tools.....	327

Cascade Views

Door.....	149
Ignore for opening resize.....	49

Cathedral Ceilings

Ceiling	
Break Lines	130
Heights	128
Ceilings	
Cathedral	130
Lowered	129
Over this room	134
Special	129
Tray	130
Center	
Doors	143
Object edit tool	90
Sheet	383
Change	
Door Swings	143
Floor/Reference	176–177
Line to arc	210
Chimneys	188
Click Stairs	205
Close	
Plans and Views	43
Program	44
Views	317
Color	
Off/On	87
Color Chooser	61, 309
Dialog	309
Eyedropper	309
Compatibility	
with other programs	31
Connect	
Electrical	230
Walls	104
Contextual Menus	50
In Render views	329
Copy	
Folders and Library Objects	292
Region as Picture	378
Copy/Paste	
Main Edit Mode	67
Sticky Mode	67
Corner	
Boards	237
Windows	157
Corner Board	
Specification Dialog	238
Create	
New Plan Dialog	32
Cross Hairs	53
Mouse	89
Toggle On/Off	89
Cross Section Slider	330
Current	
Floor	175
Floor, Delete	174
Curved	
Deck Edge	99
Deck Railing	99
Stairs	205
Walls, Draw	104
D	
Deck	
Designer	99
Edges	99
Railing	99
Decks	99, 127
Default	
Lights	338
Default Sun Light	
Specification Dialog	339
Defaults	
Cabinet	242
Defined	47
Dimension	342
Door	138
Dynamic	48
Floor	121, 171
Foundation	179
General Plan	48
Material	308
Roofs	191
Room	121
Settings	47
Wall	97
Window	155
Define Material Dialog	306

Delete	
3D Surface.....	324
Current Floor.....	174
Floors.....	174
Foundation.....	182
Gable Over Opening.....	195
Library Content.....	292
Objects.....	93
Roof Planes.....	192, 194
Wall Hatching.....	102
Dimension	
Defaults.....	342
Tab.....	352
Tools.....	345
Dimension Defaults	342
Dialog.....	342
Dimension Line	
Specification Dialog.....	352
Dimensions	
Editing.....	347
End to end.....	345
Exterior.....	346
Locate railings.....	115
Move Objects Using.....	350
Moving Labels.....	348
Number Height.....	352
Tape Measure.....	346
Zeroes in.....	344
Display	
3D Views.....	323
Drawing Groups.....	87
Electrical.....	231
Foundations.....	180
Images.....	372
Objects.....	59
Room labels.....	126
Terrain.....	262
Walls, Railings, and Fences.....	105
Display Options Dialog	60
Distributed Object Tab	266
Divided Lites <i>see Lites</i>	
Doll House View	321–322
Door	
Defaults.....	138
Specification Dialog.....	147
Tools.....	139
Doors	
Bifold Doors.....	140, 145
Casing.....	149
Center.....	143
Change Opening/Hinge Side.....	144
Change Swing Side.....	144
Doorways.....	139
Frame.....	150
Gables Over.....	194
Garage.....	140
Garage, opening direction.....	145
Handles.....	151
Hardware.....	151
Hinged Doors.....	139, 143
Hinges.....	151
Labels.....	142
Library.....	140, 148
Lites.....	150
Lites, styles.....	150
Locks.....	151
Openings in railings.....	146
Pocket Doors.....	140, 145
Rough opening.....	148
Size.....	148
Sliding Doors.....	144
Style.....	148
Swing, change.....	143
Threshold lines.....	141
Transoms.....	146
Type.....	148
Wrapped Openings.....	146
Doorways	
Adding a Door.....	141
with Railing.....	146
Dormers	
Gable Over Door/Window.....	194
Draw	
Curved Railing.....	104
Curved wall.....	104
Drawing Groups	87
Drawing Sheet	
Center.....	383
Driveways	273
Dynamic	
Defaults.....	25, 48

Print Preview383

E

Edit

Handles 20
Preferences 53
Toolbar 21

Edit Area 73

Edit Handles 20

Electrical

Auto Place Outlets230
Connections.....230
Deleting.....232
Displaying.....231
Editing Objects.....231
General228
Labels231
Library.....231
Lights229
Outlets229
Switches.....229
Tools.....229
Wiring.....230

Electrical Service

Specification Dialog.....232

Elevation Views322

End

Cabinets249
To-End Dimensions.....345

Enhanced Metafiles376

Error Messages405

Estimating Software396

Exit Program 44

Expand/Collapse All.....285

Export

EMF376
From the Library293
Materials List396
Picture Files.....375
Windows Metafiles376
Windows Metafiles Dialog.....376
WMF376

Extend

Slope Downward 112

Extension Lines

Adding 349
Deleting 350
Editing 349

Extension Snaps 64

Exterior

Dimensions 346
Room types 124
The Exterior Room 122
Walls 99

F

F6 Key

Fill Window 312

Faster Rendering 340

Fence Designer 99

Fencing 99

Field of View 330

File

Backing Up Your Files 35
Create New 32
Management 30
Open 37
Organization 31

Fill

Window 312
Window Building Only 312

Filter

Library Search..... 287

Final View 337

with Shadows 337

Find Plan Wizard..... 39

Fire Box Tab 187

Fireplace

Direction facing 185
Interior wall 185
Library 187
Masonry..... 184
Prefabricated..... 187
Specification Dialog 185

Symbol 187

Fireplaces 184

Chimneys..... 188

Foundations 185

Freestanding..... 185

In walls 184

Types 184

Fixtures

Lights 229

Resizing..... 49

Floor

3D Overview 320

Build New Floor..... 172

Camera..... 320

Defaults 121, 171

Heights 128

Overview 320

Tools 172

Floor Plan

Drawing 25

View 26

View Template (Print Model) 390

Floors

Adding 172

Attic..... 176

Change Floor/Reference 176–177

Current Floor..... 175

Deleting 174

Floor Up/ Floor Down..... 176

Maximum number 170

Reference Floor 176

Swap Floor/Reference 177

Folders Preferences 52

Fonts 354

and Alphabets 354

Footings..... 179

Foundation

Auto Rebuild 181

Defaults 179

Walls 100

Foundations

Build 179

Daylight Basement 184

Delete 182

Display 180

Garage..... 182

Room supplies floor 134

Stem Wall..... 179

Stepped 184

Framing

3D Overview..... 322

Full

Height Cabinets 243

Overview 320–321

Furniture

Resizing 49

G

Gable

Over Door/Window..... 194

Garage

Door Tool 140

Garages

Foundation 182

Garden Bed

Kidney Shaped 261

Polyline 261

Round 261

Tools..... 261

General 171

Cabinet Defaults 243

Preferences..... 52

Getting Help..... 27

GFCI Outlet 229

Glass House

Options Dialog..... 340

View..... 339

Grid

Snap Units 49

Snaps 49, 64

Ground Fault Circuit Interrupt 229

H

Half

Walls..... 117

Hardware Tab	
for Doors	151
Hatch	
Wall.....	102
Height	
Railings	118
Help	
Display	20
Tool Tips	27
Home Designer	
Product Key	28
Version Number	28
Hotkeys	21, 57
House Wizard	104, 366
Editing Rooms	367
Multiple Floors	368
Placing Rooms.....	367

I

Icons	
Arrange	317
Image	
Specification Dialog.....	373
Images	337
Adding to Library.....	372
Creating	372
Displaying.....	372
Editing.....	373
Place.....	371
Printing.....	388
Select from library	270
Interior	
Fireplace, wall.....	185
Room types	124
Invisible Walls	101

K

Keyboard	
Commands	21, 57, 285
Kidney Shaped	

Garden Bed.....	261
Pond.....	261
Terrain Features.....	260
Kitchen Island	250
Knee Walls	113, 116

L

Labels	
Door	142
Electrical.....	231
Room.....	126
Window.....	159
Landing	211
Landings	
Custom Shapes.....	211
Height.....	212
Landscape Designer	258
Landscape Orientation	386
Layer	
Layer Sets	59
Layers	
Primary and Secondary.....	59
Turn off to speed up 3D views.....	340
Left Mouse Button	
Definition	19
Library	
Adding Folders	291
Bonus Catalogs.....	287
Content.....	287
Deleting Content.....	292
Export	293
Renaming Libraries	291
Search	286
Shortcuts	292
Trash	292
Library Browser	283
Adding Items	290
Docking	286
Panels	283
Preferences	51
Restore Position.....	52
Library Object	

Specification Dialog 297

Library Objects

Editing 297

Placing 293

Light Sources 337

Default Lights 338

Default Sun Light 338

Fixtures 338

Lights

Connect to switch 230

Fixtures 229, 338

Turn On/Off 338

Line Specification Dialog 363

Lites

Craftsman 167

Diamond 167

Doors 150

Normal 167

Prairie 167

Tab 167

Living Area 127

and Room Types 125

Calculation 127

Delete label 127

Label 127

Restore label 127

vs. Footprint 127

M

Main

Edit Mode 67

Manual

Dimensions 345

Marquee Select 72

Masonry

Fireplace 184

Material

Defaults 308

Eyedropper 303

Material Painter 301

and Walls 303

Blending 302

Modes 301

Using 302

Materials

Add to Library 290

Artwork 306–307

Blending 305

Brightness 308

Calculating amounts 278

Color 307

Create using Color Chooser 309

Creating 305

Define Material Dialog 306

Editing 304

On Soffits 278

Tab 303

Textures 336

Walls 105

Materials List 392

Calculate from All Floors 393

Conditioned Areas 396

Display Options Dialog 394

Editing 395

Estimating software 396

Export 396

Menus 21

Message Boxes

Reset 23

message URL http

[//www.homedesignersoftware.com/
useraccess/content.html](http://www.homedesignersoftware.com/useraccess/content.html) 289

Metafile Size Dialog 376

Metafiles 376

Middle Mouse Button 19, 311

Minimum

Alcove 193

Model Maker

Floor Plan View Template 390

Printing 389

Molding

in Rooms 134

Moldings Tab

for Rooms 134

Monolithic Slab 179

Mouse Buttons

Using 19

Move	
Along Rails	108
Folders and Library Objects	292
Object Using Dimensions.....	350
Objects.....	88
Restrictions.....	88
to Front of Group.....	87
Walls with Cabinets Attached.....	248
Mullions	
Window	167
Multiple	
Floors, Reverse Plan.....	93
Select.....	72
Muntins	
Window	167

N

Newels	
Definition	206
No Locate Wall	115

O

Object	
Based Design	18
Object Snaps	63
Extension Snaps	64
One-Click Auto Dimension	346
One-Click Stairs	205
Open	
Below	125
Object	23
Plan Files	37
Symbol	297
OpenGL	319
Optimizations On	54
Organizing	
your Files.....	31
Orthogonal Views	383
Outlets	229
Above cabinet.....	232

Automatic.....	230
Dishwasher	229
For appliance	232
GFCI.....	229
Manually placed	229
Place	230
Sink	229
WP	229
Overview	16
Camera tools.....	327
Full	321

P

Page Setup Dialog	386
Painting	
Over Materials.....	305
Pan	
Pan Window Tool	313
the Display	312
Using the Keyboard	312
Using the Mouse	313
Using the Scroll Bars	312
Paragraph Options Dialog	357
Partition Tool	244
Paste	66
Hold Position.....	67
in Place.....	67
Special	68
PDF	
Print to.....	385
Peninsula Radius Cabinets	250
Picture	
Copy Region as.....	378
Picture File Box	
Specification Dialog	376
Picture Files	
Export.....	375
Import	375
Scale	378
Pitch	
Above Wall.....	112
Place	

Open with middle rail.....	117	Tab.....	115
Openings.....	146	Tools.....	191
Solid.....	117	Roof Designer	191
Stairs.....	214	Roof Hole/Skylight	
Type.....	117	Specification Dialog.....	196
Rebuild	192	Roof Planes	
3D.....	332	Delete.....	194
Roofs.....	192	Roofs	190, 192
Redo	94	Build Roof Dialog.....	192
Reference		Defaults.....	191
Display Options.....	177	Hole for skylights.....	195
Render		Knee walls.....	113
Graphics card.....	319	Min. Alcove.....	193
Light Sources.....	337	Overhang.....	193
Preferences.....	54	Pitch.....	112
Status.....	55	Skylights.....	195
Tips.....	336	Story-and-a-half.....	113
Reset		Room	
Message Boxes.....	23	Defaults.....	121
Preferences.....	55	Specification Dialog.....	131
Reshape objects	91	Room Labels	126
Resize		Display.....	126
Fixtures & Furniture.....	49	Edit.....	126
House using Dimensions.....	351	Interior room area.....	126
Objects.....	90	Interior room dimensions.....	126
Restrictions		Room area.....	126
Moving objects.....	88	Standard room area.....	126
Reverse		Rooms	
Plan.....	93	Area.....	126
Rich Text		Attic.....	124
Specification Dialog.....	355	Auto Place Outlets.....	125
Text Color.....	356	Below Stairs.....	216
Right Button Definition	19	Ceiling over.....	134
Road Objects		Editing.....	123
Different Types.....	273	Exterior types.....	124
Roads		Foundation floor definition.....	134
Displaying.....	273	Interior.....	124
Roof	190	Interior area.....	126
Extend Slope Downward.....	116	Interior dimensions.....	126
Full Gable Wall.....	115	Living Area.....	125
Over this room.....	134	Name for PlanCheck.....	369
Pitches in Degrees.....	198	Open Below.....	125
Second pitch.....	116	Roof over.....	134
Styles, Automatic.....	192	Room Definition.....	121
		Room Types.....	124
		Selecting.....	122

Standard area 126
 The Exterior Room 122
 Types 124
Rotate objects 92
Round
 Garden bed 261
 Pond 261

S

Sash and Frame Tab 166
Save
 and Save As 33
 Plan 33
Scale 386
 Picture Files 378
 Printing to 383
 Text Size 361
 to Fit 384
Schematics, Wiring 230
Scroll Bars 312
Seat
 in Bay Window 162
Select
 Components of Blocked Units 158
 Library Object Dialog 295
 Marquee 72
 Multiple Objects 72
 Next Object 72
 Objects button 71
 Objects in 3D Views 331
 Room 122
 Selected Edge 71
 Shift+Click 72
 Similar Objects 71
Selection Fill Color 51
Service Data Tab 233
Shelf 244
Shelf Tool 244
Shelf/Partition
 Specification Dialog 256
Shift Key
 Marquee selection 72

Select multiple objects 72
Shininess 308
Shortcut Keys 21, 57
Shutters 168
Sidewalk 273
Skylights 191, 195
Sliding Doors 139
Snap Behaviors 63
 Angle Snaps 64
 Extension Snaps 64
 Grid Snaps 64
 Object Snaps 63
Snap Unit 49
Soffit
 Defaults 276
 Specification Dialog 279
Soffits 243, 276
 Calculating Materials 278
 Corner 277
 Special applications 277
Special
 Shaped Cabinets 249
Specification Dialogs
 Bay/Box Window 169
 Cabinet 251
 Camera 333
 Corner Boards 238
 Default Sun Light 339
 Dimension Line 352
 Door 147
 Electrical Service 232
 Fireplace 185
 Image 373
 Library Object 297
 Line 363
 Plant Image 269
 Polyline 363
 Quoins 239
 Rich Text 355
 Roof Hole/Skylight 196
 Room 131
 Shelf/Partition 256
 Soffit 279
 Stair Landing 222
 Staircase 217

Error Messages	405
Installation Issues.....	403
Online.....	407
Online Articles.....	407
Telephone.....	407
Terrain	
and 3D Draw Time.....	263
Auto Rebuild	262
Breaks	260
Build	262
Displaying.....	262
Editing.....	263
Feature Tools.....	260
Specification Dialog.....	263
Terrain Feature	
Specification Dialog.....	265
Terrain Features	
Clip.....	265
Height.....	265
Terrain Modeler	
3D Views	263
Terrain Path	
Specification Dialog.....	268
Terrain Perimeter	258
Text	
Arrows	362
Bullets	357
Copy, Cut and Paste.....	361
Creating.....	355
Displaying.....	355
Editing.....	360
Layer.....	355
Line Spacing	357
Move	360
Numbering	357
Paragraph Options	357
Printed Size	361
Reshape	360
Resize	361
Rotate.....	360
Scaling	361
Specification Dialog.....	358
Textures	336
Tiling Views	316
Toolbars	20

Drop-Down	57
Edit.....	21
Hide.....	57
Parent-Child	57
Tool tips	20
Transom Windows	146
Transparency	308

U

Undo	94
Files.....	37
Undo Zoom	311
Unrestricted Movement	88
Untitled Plan	
see New Plan	

V

Vents	157
Video Card	
Memory	319
OpenGL	319
Status	55
Videos	
View Online Help Videos.....	399
Views	
Cascade.....	314
Tiling.....	316
Virtual Graph Paper	48
Visual CAD Snaps	48
Volume	
Of a Polyline.....	222

W

Walkthroughs	379
Pause Recording	379
Playing.....	379
Recording.....	379
Save Frame.....	379

Stop Recording	379	Water Features	261
Wall		Water Proof Outlet	229
Assemblies	113	Winders	
Cabinets	243	Definition	206
Defaults	97	Window	
Specification Dialog	114	Defaults	155
Tools	97	Seat	162
Wall Hatch		Specification Dialog	164
Specification Dialog	119	Windows	
Walls		Bay & bow dimensions	161
Align between floors	111	Bay Box & Bow	161
Align colinear	110	Bench Seat	162
and Material Painter	303	Cascade	314
Attic Walls	112	Component	161
Connecting	104	Corner	157
Curved	104	Gables Over	194
Curved, align between floors	111	Labels	159
Delete hatching	102	Library	156
Display surfaces only	105	Mulled Units	158
Drawing	103	Mullions	167
Editing	107	Muntins	167
Exterior and Interior	99	Shutters	168
Flip layers	103	Special Shapes	157
Foundation	100	Stacked	157
Full Gable Wall	115	Transom	146
Grid snapping	103	Types	155
Half	117	Vents	157
Hatching	102	Windows Metafiles	376
Heights	109	Wiring Schematics, Creating	230
Interior, fireplace in	185	Wrapped	
Invisible	101	Openings	146
Knee Wall	116	Stairs	213
Length	109		
Materials	105		
Move Along Rails	108		
No Locate	115		
No Room Def	115		
Opening with Railing	146		
Openings in	103		
Removing Breaks	104		
Resizing Using Dimensions	351		
Reverse Layers	103		
Solid Railings	117		
Thickness	109		

Z

Zero	
in Dimensions	344
Zoom	311
Fill Window	312
Mouse Wheel	20, 311
Tools	311
Undo Zoom	311

